



**GCAA**  
دولة الامارات العربية المتحدة  
الهيئة العامة للطيران المدني  
UAE General Civil Aviation Authority

AAIS Case Reference: 13/2010

# **AIR ACCIDENT INVESTIGATION SECTOR**

## **FINAL**

# **AIR ACCIDENT INVESTIGATION REPORT**

Uncontained Cargo Fire Leading to Loss of Control  
Inflight and Uncontrolled Descent Into Terrain

Boeing 747-44AF  
N571UP  
Dubai  
United Arab Emirates  
03 September 2010

General Civil Aviation Authority  
of the  
United Arab Emirates

Accident Investigation Sector  
General Civil Aviation Authority  
United Arab Emirates



AIR ACCIDENT INVESTIGATION SECTOR STATEMENT

THIS INVESTIGATION HAS BEEN CARRIED OUT IN ACCORDANCE WITH THE UNITED ARAB EMIRATES CIVIL AVIATION REGULATION CAR PART VI CHAPTER 3 AND ICAO ANNEX 13 TO THE CONVENTION ON INTERNATIONAL CIVIL AVIATION.

THE SOLE OBJECTIVE OF THE INVESTIGATION OF INTO THIS ACCIDENT IS THE PREVENTION OF FUTURE AIRCRAFT ACCIDENTS AND INCIDENTS.

IT IS NOT BE THE PURPOSE OF THIS INVESTIGATION TO APPORTION BLAME OR LIABILITY.

## TABLE OF CONTENTS

INTRODUCTION .....	8
REPORT ORGANISATION .....	8
ACCIDENT SYNOPSIS .....	10
INDEX OF TABLES/PHOTOS/DIAGRAMS.....	15
FLIGHT TRACK AND ELAPSED TIME FOR KEY EVENTS .....	19
1. FACTUAL INFORMATION.....	20
Accident/Incident Data Reporting [ADREP] Classifications: .....	21
1.1 History of the Flight .....	22
15:14[01]:Inflight Turn Back/Emergency Descent .....	24
15:15[02]:Arming and Activation of the Fire Suppression System .....	24
15:15[02]:Crew Don Oxygen Masks/Intra-cockpit Communication .....	24
15:15 to 15:16[02]:Pitch Control Anomalies .....	25
15:17[04]:Smoke in the Cockpit-Reduced Visibility Due to Smoke .....	26
15:18[05]:Flight Management Computer [FMC] Inputs .....	26
15:20[07]:Crew Oxygen System Anomalies – Captain and First Officer .....	27
15:22[09]:Pilot Incapacitation - Captain .....	27
15:22-15:37[09-24]:Radio Communication - Relay Aircraft/Transit to DXB.....	27
15:22-15:37[09-24]:Radio Communication on the Guard Frequency 121.5 MHz.....	28
15:38[25]:Missed Approach to DXB Runway 12 Left.....	28
15:38[25]:Over Flight of DXB RWY 12 Left.....	29
15:39[26]:Alternate Diversion Option of Shajah International Airport [SHJ] .....	29
15:40[27]:Turn And Descent Followed By Uncontrolled Flight Into Terrain .....	30
15:41[28]:Loss of Control Inflight followed by an Uncontrolled Descent Into Terrain-Data Ends ..	31
1.2 Injuries to Persons.....	32
1.3 Damage to the Aircraft .....	32
1.4 Other Damage.....	32
1.5 Personnel Information .....	32
1.5.1 Flight Crew Information.....	32
1.5.2 Scheduling.....	33
1.5.3 The Captain .....	33
1.5.4 The First Officer .....	34
1.6 Aircraft Information .....	35
1.6.1 General Aircraft Information .....	35
1.6.2 Mass and Balance .....	36
1.6.3 Body Stations [STA].....	36
1.6.4 Boeing 747 Class E Cargo Compartment .....	37
1.6.5 Performance .....	38
1.6.6 Instrument Landing System – Description.....	38
1.6.7 Crew Alerting – Fire .....	38
1.6.8 Oxygen System.....	39
1.6.9 Crew Oxygen Bottle Installation .....	40
1.6.10 Oxygen Distribution To The Flight Deck.....	40
1.6.11 Crew Alerting – Crew Oxygen Low Warning.....	41
1.6.12 Oxygen Stowage Box (MXP147-3) and Masks .....	41
1.6.13 Oxygen Masks Operation.....	41

1.6.14	Oxygen Mask Details.....	43
1.6.15	Mask Stowage Box [MXP147-3] Location .....	44
1.6.16	Environmental Control Systems .....	45
1.6.17	Air Conditioning and Pressurization .....	45
1.6.18	Fire Suppression.....	45
1.6.19	Lower Lobe Cargo Compartment Fire Protection Systems.....	46
1.6.20	Flight Deck Smoke Evacuation Shutter .....	46
1.6.21	Flight Control Systems .....	46
1.6.22	Control Cables.....	48
1.6.23	Control Cable Truss and Pulley Routing.....	48
1.6.24	Control Cable Truss Assembly Material Properties – Heat.....	49
1.6.25	Flight Controls - GENERAL.....	50
1.6.26	Flight Controls.....	50
1.6.27	Elevator Control System .....	52
1.6.28	Autopilot Control .....	53
1.6.29	Rudder Control System.....	53
1.6.30	Speed Brake [Spoiler] Control System .....	53
1.6.31	Landing Gear Control System .....	54
1.6.32	Brake Control System Description .....	54
1.6.33	Review of Control Performance.....	54
1.6.34	Review of Rudder Control and Speed Brake Performance.....	56
1.6.35	Review of Landing Gear Performance .....	56
1.6.36	Review of Brake Performance .....	57
1.6.37	Systems and Fire Protection Information.....	57
1.6.38	Auto Flight - Automatic Flight - Approach and Landing.....	61
1.6.39	Auto Throttle .....	62
1.7	Meteorological Information.....	62
1.7.1	Dubai [OMBD/DXB] Weather .....	62
1.7.2	Sunrise Sunset Table for OMAL/DXB September 03, 2010. ....	64
1.8	Aids to Navigation .....	65
1.8.1	OMBD/DXB - Instrument Approach Chart for Runway 12L.....	65
1.9	Communications .....	66
1.9.1	Background Information – ATC Communication .....	66
1.9.2	ATC VHF Radio Transceivers .....	67
1.9.3	Air Traffic Control.....	67
1.9.4	Bahrain Area East Control [BAE-C].....	68
1.9.5	Dubai Air Traffic Control Unit .....	68
1.9.6	Relay Aircraft Communications .....	68
1.9.7	AIP Published Emergency Frequencies - 121.50 MHz/243 MHz .....	69
1.9.8	Air Traffic Control In The Gulf Region .....	69
1.9.9	Transmission on the 121.5 MHz Aircraft Emergency Frequency.....	69
1.9.10	Aircraft Health Management and Aircraft Communications Addressing and Reporting System (AHM & ACARS) .....	71
1.9.11	Aircraft Health Monitoring .....	72
1.9.12	The Boeing 744AF Air Traffic Control Radar Beacon System, (ATC system).....	72
1.9.13	Boeing 747-400F Radio/Communications .....	72
1.9.14	Operators Standard Operating Procedures (SOP) for Radio Panel Setup and Communications.....	72
1.10	Aerodrome Information.....	78

1.10.1	UAE eAIP Effective Sept 2010 .....	78
1.11	Flight Data Recorders.....	78
1.11.1	Digital Flight Data Recorder .....	78
1.12	Wreckage and Impact Information .....	81
1.12.1	Background Information.....	81
1.12.2	Accident Scene Description .....	81
1.12.3	Wreckage Examination .....	82
1.13	Medical and Pathological Information.....	96
1.13.1	Captains Medical Data - Dubai Police Forensics Department .....	96
1.13.2	First Officers Medical Data - Dubai Police Forensics Department.....	96
1.13.3	Secondary Medical Samples Sent to the FAA Civil Aerospace Medical Institute (CAMI) .....	96
1.14	Fire .....	97
1.14.1	In-flight Phase .....	97
1.14.2	Ground Phase.....	97
1.15	Survival Aspects .....	97
1.15.1	Inflight Phase .....	97
1.15.2	Ground Contact/Aircraft Disintegration .....	98
1.16	Testing and Research .....	98
1.16.1	Flight Testing - Boeing 747-44AF / Boeing 747-45EF.....	98
1.16.2	Fire Testing – Batteries and Cargo Containers.....	98
1.16.3	Fire Load Contribution of Lithium and Lithium-ion Batteries.....	99
1.16.4	Burning Characteristics of Aircraft Cargo Container Fires .....	99
1.16.5	Rigid A2N Container Tests .....	101
1.16.6	Collapsible DMZ Container Tests .....	101
1.16.7	Cargo Container Study Results .....	102
1.16.8	Lithium Battery Testing.....	102
1.16.9	Aircraft Systems Testing - Crew Oxygen Delivery System Elevated Temperatures.....	103
1.16.10	Oxygen Mask Test And Verification/Tear Down Inspection .....	105
1.16.11	Boeing 747 Synthetic Training Device, Anchorage, USA.....	106
1.16.12	Boeing 747 Synthetic Training Device, Seattle, USA: Smoke Filled Environment, Checklist Verification, CRM/Human Factors and Aircraft Handling/Ditching Scenario Testing, USA.....	106
1.16.13	Boeing 747-F Familiarisation .....	107
1.16.14	Alternative Vision Systems for Smoke/Fumes in the Cockpit.....	109
1.17	Organisational and Management Information .....	110
1.17.1	Company Overview.....	110
1.18	Additional Information.....	111
1.18.1	Guidance Documentation for Lithium Battery Carriage .....	111
1.18.2	Smoke in the Cockpit - Characterising the Problem .....	113
1.18.3	Single Point of Failure [SPoF] Analysis .....	114
1.18.4	Modelling of Single Point Failures .....	115
1.18.5	Cargo Compartment Classification Revision Following Cargo Compartment Fire Events.....	116
1.18.6	Class F Cargo Compartment – Modification of Existing Standards .....	117
1.18.7	ICAO Annex 08 - Airworthiness of Aircraft .....	118
1.18.8	Cargo Containers and Pallets.....	118
1.18.9	Fire Suppression.....	119
1.18.10	Lithium Batteries - Assessing The Risk.....	120
1.18.11	Lithium Ion Batteries – Description[Typical].....	121
1.18.12	Cell and Battery Failure Modes.....	122

1.18.13	Smoke in the cockpit.....	123
1.18.14	Heat and Combustion By-products.....	123
1.18.15	Controlling Smoke Penetration.....	124
1.18.16	B747 Cargo Fire Related Accidents.....	124
1.18.17	Cargo Compartment Acoustic/Vibration Mapping – Structural Acoustic Coupling in Aircraft Fuselages.....	125
1.19.	Useful or Effective Investigation Techniques.....	126
1.19.1.	Airbus A330 Synthetic Training Device, Abu Dhabi, UAE: Smoke/Fire/Fumes Vision Assistance Testing.....	126
1.19.2.	NTSB CVR Sound Spectrum Analysis.....	126
1.19.3.	Boeing Google Earth Application Combining DFDR Data, ATC Transcripts and Spatial Information.....	127
2.	ANALYSIS.....	128
2.1	Flight Data Analysis – Flight Profile.....	130
2.1.2	Basic Workload Functions.....	149
2.2	Digital Flight Data Analysis.....	151
2.2.1	Digital Flight Data Factual Analysis - Flight Controls.....	151
2.2.2	Summary/Assessment of the DFDR data (Flight Controls).....	157
2.3	Inflight Turn Back To Dubai Verses Diverting To Land At The Nearest Suitable Airport At Doha Or Ditching In The Gulf.....	158
2.3.1	Factors Influencing Pilot Decision Making During the Diversion/Return To Dubai.....	159
2.3.2	Ditching Option.....	160
2.4	Freighter Accident Rate Predictions.....	161
2.4.1	Freighter Airplane Cargo Fire Risk, Benefit and Cost Model.....	161
2.5	Determination The Fire Location Using The Aircraft Communications Addressing and Reporting System [ACARS] and the Aircraft Health Monitoring [AHM] Data.....	162
2.6	Probable Time of the Pallet Fire Ignition.....	167
2.7	Source of Ignition and Cargo Fire Sequence.....	168
2.8	Airconditioning PACK One History.....	169
2.9	Cargo Compartment Liner Certification Deficiencies.....	170
2.9.1	Cargo compartment Liner Damage Tolerance.....	170
2.10	Fire Suppression Methodology – Climb or Descend to 25,000 ft.....	171
2.11	Single Point of Failure Analysis [SPoF].....	172
2.12	Emergency Flight Management.....	173
2.12.1	Procedure and Methodology.....	173
2.12.2	Non-Normal Checklist Crew Advisory and Fire Suppression Methodology.....	174
2.13	Smoke Penetration – Upper Deck Cockpit and Supernumerary Area.....	175
	Smoke Density/Soot Deposits.....	175
2.14	Smoke and Reduced Cockpit Visibility.....	176
2.15	Pilot Incapacitation.....	177
2.16	Access to Cockpit Emergency Equipment from the Pilot Seated Position.....	178
2.17	Recording Devices - Visual.....	179
2.18	PHMSA/HMR/ICAO Technical Instructions.....	179
2.19	Protection of Critical Systems.....	180
2.20	CVR Sound Spectrum – Determining The Oxygen Mask Settings.....	181
2.21	Crew Training – Smoke, Fire, Fumes.....	181
2.22	Computer Model Thermal Analysis of a Container Fire in a Class E Cargo Compartment.....	182

2.23	Communications .....	183
2.24	Checklist – Smoke, Fire and Fumes – Format Improvements.....	183
2.25	Audible Checklists – Smoke, Fire and Fumes .....	184
2.26	Accident Comparison Between GCA Case#13-2010 and ARAIB Case# AAR1105 .....	186
3.	FINDINGS, CAUSES AND CONTRIBUTING FACTORS .....	188
3.1	FINDINGS.....	188
3.2	CAUSES.....	194
3.3	CONTRIBUTING FACTORS.....	195
4.	SAFETY RECOMMENDATIONS.....	197
5.	APPENDICES .....	203
A:	CARGO FACTUAL REPORT.....	203
B:	OXYGEN MASK AND OXYGEN HOSE TESTING AT ELEVATED TEMPERATURES .....	217
C:	ZODIAC MASK TESTING.....	229
D:	FAA/NTSB REPORT FIRE LOAD CONTRIBUTION OF LITHIUM AND LITHIUM ION BATTERIES REPORT	239
E:	NTSB SIMULATOR SESSIONS – SEATTLE.....	274
F:	NTSB SIMULATOR SESSION – ANCHORAGE .....	289
G:	GCAA EVAS EVALUATION/CRM REVIEW .....	296
H:	NTSB CVR – SOUND SPECTRUM ANALYSIS.....	299
I:	FLIGHT DATA – FLIGHT GENERAL PROFILE .....	320
J:	SMOKE FIRE AND FUMES IN TRANSPORT AIRCRAFT SPECIALIST PAPER.....	321
	GCAA AIR ACCIDENT INVESTIGATION SECTOR GENERAL INFORMATION .....	322

## INTRODUCTION

---

This Final air accident final report contains information on the investigation into an accident involving a Boeing 747-44AF, registration N571UP, on the 3<sup>rd</sup> September 2010, near Dubai in the United Arab Emirates.

The information contained in this final report is published to inform the aviation industry and the public of the general circumstances of the accident.

This factual report supersedes all previous Preliminary and Interim air accident reports concerning this accident investigation.

The GCAA as the investigation authority in charge of the investigation has worked in close cooperation with an Accredited Representative [Acc Rep] from the National Transportation Safety Board (NTSB) and an investigation representative from the European Aviation Safety Agency (EASA).

The NTSB Acc Rep was assisted by technically qualified advisors from the aircraft manufacturer, the Federal Aviation Administration (FAA), the aircraft operator and the labour union representing the pilots of the operator.

In accordance with Annex 13 to the Convention on International Civil Aviation the sole objective of the investigation is to determine the causal factors of the accident and the significant factors that influenced the outcome.

Having established all of the relevant factors, this air accident Investigation final report will advise of the safety recommendations intended to prevent a reoccurrence.

## REPORT ORGANISATION

---

This report was prepared in accordance with International Civil Aviation Organization Standards And Recommended Practices [SARPs] and the GCAA CAR Part VI Chapter 3 for investigation reports. The report follows the ICAO Annex 13 SARPS regarding the final report format.

The ICAO Annex 13 report format is in five main sections as detailed below.

- **1. Factual Information:** Provides factual information that is relevant to understanding the chronology and circumstances of this occurrence. Part 1, Factual Information, has nineteen [19] sub-headings detailing each aspect of the investigation to be reported.
- **2. Analysis:** Reviews, evaluates and analyses the factual information presented in the part one, Factual Information of the investigation. This varies from theoretical analysis to laboratory and full scale testing
- **3. Conclusions:** Based on the analyses of the factual information, presents the Findings and the Causal factors

Findings are statements of all significant conditions, events or circumstances in the accident sequence. The findings are significant steps in the accident sequence, but they are not always causal of indicate deficiencies.

- i **Causes** are actions, omissions, events, conditions, or a combination thereof, which led to this accident.
- ii **Contributing factors** are actions, omissions, events, conditions, or a combination thereof, which, directly contributed to the Accident and if eliminated or avoided, would have reduced the probability of this Accident occurring, or mitigated the severity of its consequences.



- **4. Safety Recommendations:** Based on the findings of the investigation, recommends safety actions required to be taken to eliminate or mitigate safety deficiencies, and records the main actions already taken or being taken by the affected entities involved through the process of immediate Prompt Safety Recommendations.

Note: Owing to the scope of this investigation and the requirement to perform detailed analysis of the findings, information required to develop a complete understanding of the events and timeline of the accident and the subsequent understanding of the facts, analyses, conclusions, and safety recommendations are referenced throughout the report or can be located in the appendices.

- **5. Appendices:** these are reference documents provided as documentary evidence, supporting information or technical information to support the analysis and conclusions which for reasons of clarity are excluded from the factual information recorded in the report sections part 1 & 2.

## ACCIDENT SYNOPSIS

---

On September 3<sup>rd</sup> 2010, a Boeing 747-44AF departed Dubai International Airport [DXB] on a scheduled international cargo flight [SCAT-IC] to Cologne [CGN], Germany.

Twenty two minutes into the flight, at approximately 32,000 feet, the crew advised Bahrain Area East Air Traffic Control [BAE-C ] that there was an indication of an on-board fire on the Forward Main Deck and declared an emergency.

Bahrain Air Traffic Control advised that Doha International Airport [DOH] was 'at your ten o'clock and one hundred miles, is that close enough?', the Captain elected to return to DXB, configured the aircraft for the return to Dubai and obtained clearance for the turn back and descent.

A cargo on the main cargo deck had ignited at some point after departure. Less than three minutes after the first warning to the crew, the fire resulted in severe damage to flight control systems and caused the upper deck and cockpit to fill with continuous smoke.

The crew then advised Bahrain East Area Control [BAE-C] that the cockpit was 'full of smoke' and that they 'could not see the radios', at around the same time the crew experienced pitch control anomalies during the turn back and descent to ten thousand feet.

The smoke did not abate during the emergency impairing the ability of the crew to safely operate the aircraft for the duration of the flight back to DXB.

On the descent to ten thousand feet the captains supplemental oxygen supply abruptly ceased to function without any audible or visual warning to the crew five minutes and thirty seconds after the first audible warning. This resulted in the Captain leaving his position. The Captain left his seat and did not return to his position for the duration of the flight due to incapacitation from toxic gases.

The First Officer[F.O], now the Pilot Flying [PF] could not view outside of the cockpit, the primary flight displays, or the audio control panel to retune to the UAE frequencies.

Due to the consistent and contiguous smoke in the cockpit all communication between the destination [DXB] and the crew was routed through relay aircraft in VHF range of the emergency aircraft and BAE-C.

BAE-C then relayed the information to the Emirates Area Control Center (EACC) in the UAE via landline, who then contacted Dubai ATC via landline.

As the aircraft approached the aerodrome in Dubai, it stepped down in altitude, the aircraft approached DXB runway 12 left (RWY 12L), then overflew the northern perimeter of the airport at 4500 ft at around 340 kts . The PF could not view the Primary Flight Displays [PFD] or the view outside the cockpit.

The PF was advised Shajah International Airport [SHJ] was available at 10 nm. This required a left hand turn, the aircraft overflew DXB heading East, reduced speed, entering a shallow descending right-hand turn to the south of the airport before loss of control in flight and an uncontrolled descent into terrain, nine nautical miles south west of Dubai International Airport.

There were no survivors.

<b>ABBREVIATIONS/TERMINOLOGY/PHRASES</b>	
ACARS	Aircraft Communications Addressing and Reporting System
ACC	Area Control Center
ACP	Audio Control Panel
AFDS	Auto Flight Director System
AHM	Aircraft Health Monitoring
AHMS	Aircraft Health Management System
AIP	Aeronautical Information Publication
AIRS	Airborne Image Recording System
AMJ	Air Cargo Containers
AP	Autopilot
A/P	Autopilot
APP	Approach
APU	Auxiliary Power Unit
ARR	Arrival
A/T	Auto Throttle
ATC	Air Traffic Control
ATCO	Air Traffic Control Operator
ATCU	Air Traffic Control Unit
ATES	Air Traffic Engineering Services
BAE-C	Bahrain East Air Traffic Control or Bahrain Area East Control
BALUS	Waypoint
BCF	Boeing Converted Freighter
C	Center
CAD	Computer Aided Design
CAM	Cockpit Area Microphone
CAMI	Civil Aerospace Medical Institute
CAPT/CP	Captain
CAVOK	Ceiling and Visibility are OK
CBT	Computer Based Training
CDU	Control Display Unit
CET	Civil Evening Twilight
CFR	Code of Federal Regulations
CGN	Cologne Airport [IATA Code]
CMC	Central Maintenance Computer
CMU	Communication Management Unit
COPPI	Waypoint
CPC	Cabin Pressure Controller
CRES	Corrosion Resistant Steel
CRM	Crew Resource Management
CS	Certification Specifications

CTA	Control Area
CVR	Cockpit Voice Recorder
DAC	Designated Area of Coverage
deg	Degree (a degree of arc)
DFDR	Digital Flight Data Recorder
DME	Distance Measuring Equipment
DOC	Designated Area of Coverage
DOH	Doha International Airport [IATA Code]
DOT	Department of Transportation
DXB	Dubai International Airport [IATA Code]
DXB - ATC	Dubai Air Traffic Control
EACC	Emirates Area Control Center
EASA	European Aviation Safety Agency
ECS	Environmental Control System
EDDK	Cologne/Bonn Airport [ICAO Code]
EGPWS	Enhanced Ground Proximity Warning System
EICAS	Engine Indication and Crew Alerting System
EVAS	Emergency Vision Assurance System
FAA	Federal Aviation Administration
FAR	Federal Aviation Regulations
FCC	Flight Control Computer
FEM	Finite Element Model
FL	Flight Level
FDE	Flight Deck Effect
FDR	Flight Data Recorder
FIM	Fault Isolation Manual
FIR	Flight Information Region
FLC	Flight Level Change
FLCH	Flight Level Change
FMC	Flight Management Computer
FMS	Flight Management System
F/O	First Officer/Co-pilot
FOQA	Flight Operational Quality Assurance
FP	Flight Profile
FRP	Fibre Reinforced Plastic
FWD	Forward
GCAA	General Civil Aviation Authority
GMT	Greenwich Mean Time
G/S	Glide Slope
GST	Gulf Standard Time
HazMat	Hazardous Material
HF	High Frequency
IA	Initiating Action
IAD	International Air Distress

IATA	International Air Transport Association
ICAO	International Civil Aviation Organisation
IFR	Instrument Flight Rules
ILS	Instrument Landing System
IVU	Inflatable Vision Unit
KHz	Kilo Hertz
KT/kt	Knot
L	Left
LBL	left buttock line [Datum]
LH	Left Hand
LNAV	Lateral Navigation
LOC	Localizer
MAWEA	Modularized Avionics and Warning Electronics Assembly
MCP	Mode Control Panel
MD	Main Deck
MFP	Maintenance Facility Planning Manual
MHz	Mega Hertz
MMEL	Master Minimum Equipment List
MAD	Military Air Distress
MAWEA	Modularized Avionics and Warning Electronics Assy
MMR	Multi-Mode Receiver
MOM	Multi Operator Message
MSB	Mask Stowage Box
NAV	Navigation
NNC	Non-Normal Checklist
NFPA	National Fire Protection Association
NOTOC	Notice to the Pilot in Command
NTSB	National Transportation Safety Board
OEM	Original Equipment Manufacturer
OMDB	Dubai International Airport [ICAO Code]
PACK	Preconditioned Air Unit
PANS - ATM	Procedures for Air Navigation Services
PF/PH	Pilot Flying/Pilot Handling
PFD	Primary Flight Display
PNF/PM	Pilot Non-Flying /Pilot Monitoring
PTC	Pack Temperature Controller
PTT	Push-to-Talk
PVC	Poly Vinyl Chloride
QAR	Quick Access Recorder
QRH	Quick Reference Handbook
R	Right
RANBI	Waypoint
RBL	Right Buttock Line [Datum]
RH	Right Hand

R/T	Receive/Transmit
RTB	Return To Base
RTE	Real Time Event
RTF	Radiotelephone - Communication
RWY	Runway
SAA	South African Airways
SAFO	Safety Alerts for Operators
SARPS	Standards and Recommended Practices
SATCOM	Satellite Communication
SBD	Simulated Breathing Device
SCAT-IC	Scheduled International Cargo Flight
SELCAL	Selective Calling [Communications]
SFF	Smoke/Fire/Fumes
SHJ	Sharjah International Airport
SIM	Simulator
SMACCS	Smoke Mode Air Conditioning Control System
SOP	Standard Operating Procedure
SOS	Supplemental Oxygen System
SPoF	Single Point of Failure
SRA	Surveillance Radar Approach
SRM	Stabiliser Trim/Rudder Ratio Module
SRN	Sub-frame Reference Number
SSR	Secondary Surveillance Radar
STA	Body Station
SZC	Sheikh Zayed Air Navigation Centre
TAF	Terminal Aerodrome Forecast or Terminal Area Forecast
TSO	Technical Standard Order
UAE	United Arab Emirates
UHF	Ultra High Frequency
ULD	Unit Load Device
UN	United Nations
UPS	United Parcel Service
USB	Upper Side Band
UTC	Coordinated Universal <i>Time</i>
VCCS	Voice Communication Control System
VFR	Visual Flight Rules
VHF	Very High Frequency
VNAV	Vertical Navigation
VOR	Omni Directional Radio Range
VU	Vision Unit
WL	Water Line
ZULU	Refer to Coordinated Universal Time (UTC)

Table

ABBREVIATIONS/TERMINOLOGY/PHRASES

1 -

## INDEX OF TABLES/PHOTOS/DIAGRAMS

Figure 1 – Track and Elapsed Time for Key Events.....	19
Figure 2 Inflight Turnback Fire Suppression Activation .....	25
Figure 3 DXB Overview and Track [Yellow]/SHJ location and required heading for SHJ RWY 31 localizer interception [inset top right] .....	30
Figure 4 Dubai Silicon Oasis over flight/Accident Location, Nad Al Sheba .....	31
Figure 5 B747-44AF Cockpit Layout.....	35
Figure 6 Body Stations Reference System .....	37
Figures 7- Main Deck Class E Cargo Compartment, looking aft/Pallet and container locations .....	38
Figure 8 - Crew Oxygen System Schematic.....	39
Figure 9 Crew Oxygen Bottle Location.....	40
Figure 10 Flight crew oxygen mask.....	42
Figure 11 - Location of Normal/100% switch and Press-to-test/Emergency knob.....	43
Figure 12 Captains Mask Stowage Location .....	44
Figure 13 Cable Truss and Pulley Routing Left and Right .....	48
Figure 14 Left and Right Pulley Bracket Truss – view looking aft .....	49
Figure 15 Power Control Modules/Servos/ Autopilot Control servos.....	51
Figure 16 Auto Flight Elevator Controls.....	53
Figure 17 - Control column movement to elevator deflection.....	55
Figure 18 control synchronization/desynchronisation .....	55
Figure 19 Class E Main Deck Cargo Compartment Smoke Detector Locations .....	58
Figure 20 Draw-through Smoke Detector.....	59
Figure 21 Main Deck Ceiling Transition Panels STN 718.74 TO 900 .....	61
Figure 22 Instrument Approach Chart - Dubai [OMBD/DXB] RWY12 Left.....	65
Figure 23 Relay Communication Schematic.....	66
Figure 24 - VHF Communications Range from BAH-C into the UAE FIR .....	67
Figure 25 Transcript ATC Audio of 121.5 MHz Emergency Communications Exchanges .....	70
Figure 26 Typical ACARS System – Aircraft to Ground Station .....	71
Figure 27 Fire Warning - Crew Alerts.....	97
Figure 28 A2N Cargo Container Fully Developed Fire.....	100
Figure 29 Battery Testing - Thermal Energy Release .....	103
Figure 30 Familiarization of a Boeing 747F.....	107
Figure 31: Main Deck Emergency Equipment.....	108
Figure 32: O2 mask with hose fully extended      Figure 33: Cockpit Portable Oxygen .....	108
Figure 34 Fire Tetrahedron .....	119
Figure 35 Battery Structure/Discharge Mechanism .....	121
Figure 36 - Typical Thermal Runaway Temperatures [cell type battery].....	123
Figure 37: Fire Audible Alarm - 15:15:52 UTC.....	131
Figure 38 DXB RWY 12L ILS Intercept .....	140
Figure 39 - Placard Speed.....	142
Figure 40 DXB Over flight and Relay Communication.....	143
Figure 41 DXB RWY 12L Over flight.....	143
Figure 42 - GPWS: Bank Angle Warning - 15:39:19 UTC.....	144
Figure 43 - 15:40:35 UTC Descent towards Nad Al Sheba .....	145
Figure 44 Profile: Descent and Pitch Oscillations .....	146
Figure 45 Temporary Arrested Descent.....	147
Figure 46 - 15:41:30 UTC - LOC-I/Loss Of Control In Flight/Data Ends .....	148
Figure 47 Elevator control system schematic from the Aircraft Maintenance Manual .....	152

Figure 48 Column sweep and take-off rotation.....	152
Figure 49 Column to Elevator deflections following the initial fire warnings and just prior to end of data. .....	153
Figure 50 Captain and First Officer column forces following the fire warnings .....	153
Figure 51 Rudder and rudder pedal data.....	154
Figure 52 - Spoiler deflection from speed brake handle and wheel deflection.....	155
Figure 53 Doha Diversion from point of the first fire alarm .....	158
Figure 54 Predicted Number of Freighter Airplane Fire Cargo Accidents Through to 2021.....	162
Figure 55 AHM/ACARS Derived Fire Warnings .....	163
Figure 56- Cutaway Forward Fuselage and Main Deck Cargo Compartment.....	166
Figure 57 - Pallet Locations/Fire location .....	167
Figure 58 Fire Main Deck Non Normal Checklist .....	173
Figure 59 - The Ringelmann Scale: The smoke composition and density scale.....	176
Figure 60 - View on cockpit LH sidewall - Captains supplementary oxygen supply hose and connector	221
Figure 61 : Principle scheme for oxygen regulator .....	231
Figure 62 : Scheme for MC10-25-104 comfort test set-up .....	232
Figure 63 : Photo of MC10-25-104 comfort test set-up .....	233
Figure 64: Scheme for MXP147-3 pressure switch actuation test set-up .....	233
Figure 65 : Photo of MXP147-3 pressure switch actuation test set-up.....	234
Figure 66 inflation test mask 150749.....	234
Figure 67 Inflation test mask 150750 .....	235
Figure 68 : respiratory cycle 100% position.....	236
Figure 69 : respiratory cycle emergency position.....	236
Figure 70 respiratory cycle 100% position.....	236
Figure 71 : respiratory cycle emergency position.....	237
Figure 72 : Photo of 098869 test bench.....	237
Figure 73 : pressure switch activation and de activation .....	238
Figure 74: Heat release rate from a single 18650 battery exposed to a heat flux of 30 kW/m <sup>2</sup> .....	244
Figure 75: Heat release rate from a single CR2 battery exposed to a heat flux of 50 kW/m <sup>2</sup> .....	245
Figure 76: Heat release rate from a single SF123A battery exposed to a heat flux of 50 kW/m <sup>2</sup> .....	245
Figure 77: Heat release rate from a single PL-553562-10C battery exposed to a heat flux of 75 kW/m <sup>2</sup> .....	246
Figure 78: Heat release rate from a single PL-603495-10C battery exposed to a heat flux of 75 kW/m <sup>2</sup> .....	246
Figure 79: Battery failure time versus incident heat flux .....	248
Figure 80: Test setup for batteries exposed to an unrelated fire.....	249
Figure 81: Graph of energy release rate and total energy.....	250
Figure 82: Graph of fire plume temperatures.....	251
Figure 83: Box of lithium-ion batteries burning over propane burner exhibiting battery venting and electrolyte combustion.....	252
Figure 84: Graph of radiant heat flux measurements .....	252
Figure 85: Box of batteries with cartridge heater in place (circled in red) .....	253
Figure 86: Test setup for tests involving 18 cardboard boxes and one box of batteries.....	254
Figure 87: Energy release rate from tests involving cardboard boxes and batteries.....	255
Figure 88: Energy release rate from tests involving cardboard boxes .....	255
Figure 89: A2N type container with fuel load inside .....	258
Figure 90: Smoke exiting above roll-up door on A2N type container .....	258
Figure 91: Energy release rate and observations from A2N container test 1 .....	259



Figure 92: Energy release rate and observations from A2N container test 2 .....	260
Figure 93: DMZ type container with plastic rain cover and cargo net.....	261
Figure 94: Energy release rate and observations from DMZ container test 1.....	262
Figure 95: Energy release rate and observations from DMZ container test 2.....	263
Figure 96: Smoke Evacuation Handle      Figure 97: Smoke Evacuation Handle (pulled) .....	290
Figure 98: Smoke Evacuation Handle      Figure 99: Smoke Evacuation Port (cockpit ceiling) .....	291
Figure 100: Smoke vent valve selector (closed)      Figure 101: Smoke vent valve selector (open) .....	291
Figure 102: Closest position to the MCP      Figure 103: Closest position to the FMS .....	292
Figure 104: "Push to Talk" switch .....	292
Figure 105: 100% Selector Switch on Oxygen Mask.....	293
Figure 106: Headset location after donning mask.....	294
Figure 107 – Spectrogram of CAM - Test points 1 and 3, on Ground .....	302
Figure 108 - Spectrogram of CAM - Test points 1 and 3, During Flight.....	303
Figure 109 – Spectrogram of Inspiratory Noise from Mask Microphone Audio.....	303
Figure 110 - Emergency Setting = On.....	308

## READER ADVISORY INFORMATION

Air accidents reports of complex investigations are generally technical documents, orientated towards an aviation technical audience.

As the report is a public document, this is a reader advisory to assist with the interpretation of the information for a non-technical audience. This will assist with following the sequence and chain of events covered in the factual information of the accident flight and the subsequent analysis in Section 2.

The chronology and event timeline concerning the history of the flight is linear; to assist with understanding the complex lines of information the descriptive text is supplemented with bullet points derived from the Cockpit Voice Recorder (CVR) exchanges between the crew, the ground stations and passing relay aircraft. This is for reasons of clarity to provide information where there are multiple streams of activity.

Where relevant, the diagrams and maps indicating the flight path and various critical or key information on the accident timeline are referred to and indicated by a number used to reference a map position or diagram component location, for example:

- 19:38:28|CVR|Relay: what's his airspeed? ②

The chronology of the event timeline concerning the history of the flight has been derived using the DFDR data, Air Traffic Control transcripts, Aircraft Health Monitoring (AHM) System, information, the Aircraft Communications Addressing and Reporting System (ACARS) transmissions, the Cockpit Voice Recorder (CVR) derived analysis and operational judgement.

The flight timeline covers the period of arrival of the aircraft from Hong Kong earlier in the morning of September 3<sup>rd</sup> 2010 resuming to cover the elapsed time between when the aircraft is established in flight from Dubai International Airport (DXB) until the data recording ends at 15:41:36<sup>1</sup>.

The use of maps and location graphics is used to simplify the over view of the information in this report.

To help the reader gauge the timeline chronologically from the time of the Fire Master Warning alert, a time from the from first fire warning is a sub heading in minutes of elapsed time.

Detailed analysis of the Flight Profile [FP] is contained in Section 2. Analysis

An over view map of the Flight Track and Elapsed time for Key Events is provided at the beginning of the History of Flight. This is intended as a reference only.

---

<sup>1</sup> All times are UTC

# FLIGHT TRACK AND ELAPSED TIME FOR KEY EVENTS

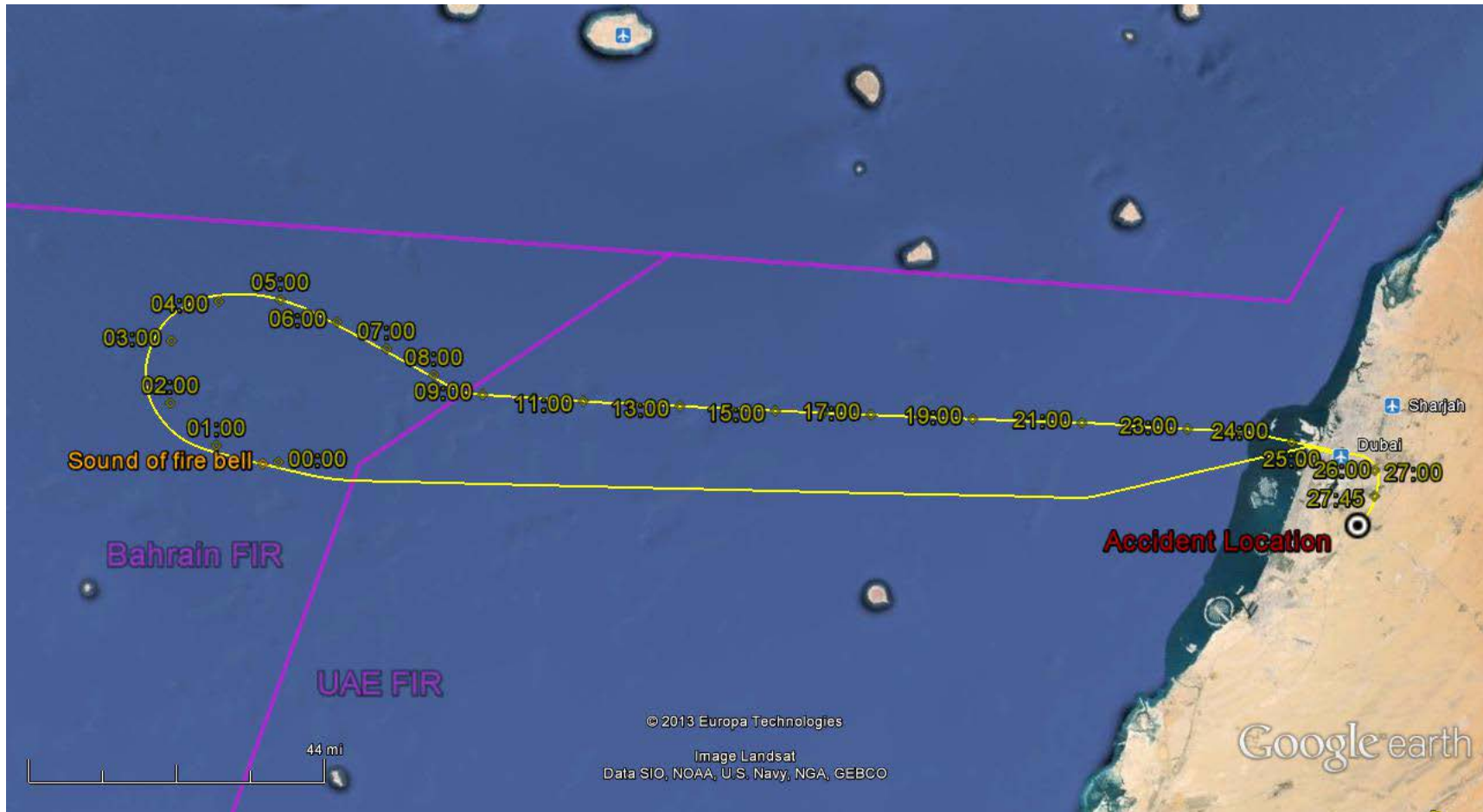

Figure 1 – Track and Elapsed Time for Key Events

## 1. FACTUAL INFORMATION

This section summarises in chronological order according to Coordinated Universal Time(UTC)<sup>2</sup>, the main events that occurred during the flight .

The investigation of this Boeing 744AF accident was complex, involving detailed investigation of multiple aspects of the accident data to determine the causal factors. This methodology uses normal investigative process such as establishing testing programs to gather, develop and analyse numerous lines of investigative information and data.

There are two phases to the flight profile:

- Phase 1, there is a two crew operating environment, for a duration of 30 minutes 31 seconds; and
- Phase 2, there is a single pilot operation, for a duration of 20 minutes 27 seconds until the data ends.

To assist with the timeline, when the fire event starts, the elapsed time from the first fire bell is shown as red in the heading, for example:

› 15:14 [01]: Inflight turn back/emergency descent<sup>3</sup>

Note: According to ICAO Annex 13 Standards and Recommended Practices regarding the structure and composition of an accident flight history, the history begins at the time the flight departs from the last known aerodrome, which is Dubai [DXB] in this particular accident.

However, in this specific investigation, the inbound flight arrival is relevant to understanding the context of the following accident flight with respect to the loading of the inbound cargo, the history of the PACK1 failures and the loading of cargo at the point of departure in Hong Kong, prior to arrival in Dubai.

Although these factors are significant to understanding the cause and sequence of events, they are not causal factors in isolation as several significant failures and consequential actions as detailed in this history of flight will illustrate.

---

<sup>2</sup> Coordinated Universal Time (UTC) is the primary time standard by which the world regulates clocks and time. To convert UTC to Gulf Standard Time, add plus [+] 4 hours.

<sup>3</sup> The phase of flight in which an intentionally rapid or premature descent, from a previously normal manoeuvre, is made in response to an in-flight emergency. the descent is controlled by the crew.

## Accident/Incident Data Reporting [ADREP] Classifications<sup>4</sup>:

---

### Primary

**F-NI: Fire/smoke (non-impact)** - Fire or smoke in or on the aircraft, in flight or on the ground, which is not the result of impact.

**SCF-NP: System/component failure or malfunction (non-powerplant)**<sup>5</sup> - Failure or malfunction of an aircraft system or component - other than the power plant.

**LOC-I: Loss of control - inflight** - Loss of aircraft control while or deviation from intended flight path inflight.

### Secondary

**UND: Uncontrolled descent** - A descent during any airborne phase in which the aircraft does not sustain controlled flight.

---

<sup>4</sup> The ADREP Occurrence category taxonomy is a set of terms used by ICAO to categorize aircraft accidents and incidents and allow safety trend analysis on these categories. The ADREP Occurrence category taxonomy is part of the ICAO accident reporting system (ADREP).

<sup>5</sup> If the failure renders the aircraft uncontrollable it is coded as SCF-NP only, not as loss of control (LOC-I or LOC-G). However, if the failure does not render the aircraft uncontrollable, but leads to a loss of control, code the event under both SCF-NP and LOC-I

## 1.1 History of the Flight

---

### Inbound Flight Arrival from Hong Kong [HKG] – Sept 03 2010

On September 3rd 2010, the Boeing 747-400AF aircraft, registered N571UP, arrived from Hong Kong [HKG] on a scheduled cargo service flight to Dubai International Airport [DXB] carrying, among other items, significant consignments of cargo that included lithium batteries. The aircraft was parked at the loading position, chocks on/block in at 11:35 UTC.

The inbound crew entered a logbook item<sup>6</sup> for a PACK 1 fault which was reset on the inbound sector from HKG-DXB.

The following scheduled sector was Dubai (OMDB/DXB) direct to Koln-Bonn, Cologne (EDDK/CGN) scheduled to depart at 14:50 UTC on the 03 September 2010 - this is the accident flight.

### Cargo Loading

Prior to the flight to Dubai, cargo was loaded into all positions in Hong Kong. A consignment of mixed cargo including a significant number of batteries, including lithium types, was loaded onto the pallets located at MD positions 4, 5, and 6, amongst other positions<sup>7</sup>. Upon arriving in Dubai, the Unit Load Devices (ULD) in positions 13L, 14L, 14R, 18L, 19L, and 20 were removed from the aircraft. Some of these ULD's were replaced with other out-bound ULD's. No cargo was unloaded from the forward section of the main deck. The Cargo Group examined shipping invoices for the cargo on board the aircraft, and at least three shipments of lithium batteries which should have been declared as hazardous materials were identified in the pallets at positions 4 and 5. There were no declared shipments of hazardous materials on board the accident flight.

### Filed Flight Plan<sup>8</sup>

The filed flight plan waypoints and airways are as follows:

OMDB RANBI N571 BALUS UL768 OTILA UR219 MODAD B544 ALE UB402 NISAP UM861 BUK UL602  
BUDOP UL850 LALIN UL604 DEMAB T842 RUNER T858 KOPAG KOPAG1C EDDK

The flight departed Dubai and proceeded to waypoint RANBI, along airway N571 to BALUS, then airway UL768 towards waypoint OTILA. The flight returned to Dubai just after passing waypoint BALUS, having crossed into the Bahrain FIR.

### Pushback, Engine Start, Taxi and Departure from Dubai International Airport

Push back and engine start were normal. The aircraft pushed back at 14:41 departing DXB at 14:51 (18:51 GST local time) on a scheduled cargo service to Koln-Bonn, Cologne (CGN), Germany.

The departure runway was runway 30 Right (RWY 30R) from DXB, a north westerly departure over the southern Arabian Gulf.

The First Officer [FO] was the Pilot Flying<sup>9</sup> (PF), the Captain [CAPT] was the Pilot Non Flying<sup>10</sup> (PNF) for the sector from DXB to CGN. At 14:50:53 the aircraft performed a normal take-off.

---

<sup>6</sup> A technical reference to a rectifiable fault

<sup>7</sup> Refer to Appendix A, Section F of this report for further information on these items.

<sup>8</sup> Refer to AIRAC AMDT 98 UAE eAIP for Enroute chart information

<sup>9</sup> Pilot Flying - handling pilot with direct responsibility for flying the aircraft for the complete flight

The aircraft was cleared for a RANBI2D departure from Dubai which required a left turn after take-off from DXB, heading west to towards the RANBI waypoint, then a right turn heading north/west overhead the RANBI waypoint towards the BALUS waypoint. The BALUS waypoint is on the Emirates Flight Information Region [FIR]/Bahrain East FIR boundaries.

14:49: Initial/Continuous Climb – PACK 1 Off line

The initial climb out from DXB was uneventful. The PF flew the aircraft manually to an altitude of 11,300 feet, then engaged the Auto Pilot [AP] for the climb to the selected cruise altitude of 32,000 feet.

The climb was uneventful until a Pack 1 fault was indicated via the Engine Indicating and Crew-Alerting System (EICAS) at approximately 10,000 ft.

The Capt, [PNF] reset the Pack<sup>11</sup>. Pack 1 fault reset by the PNF at 15:00:17, at an altitude of 12,500 ft. The Pack 1 reset was successful. All other recorded indications were normal.

- 15:00|CVR|CAPT: I'm gonna look at pack one.
- 15:00|CVR|CAPT: looks like we're good to go here. it uh basically what it said was. trim's on. pack selector A. I hit the reset

15:11: Radar Contact/Bahrain East ATC/Approaching Top of Climb [TOC]

The flight checked in with Bahrain East [BAE-C] at 15:11 on the climb to FL320. BAE-C confirms to the crew that they are on the radar at 15:11:32, the crew acknowledge the radar contact. There are no indications of any abnormalities.

15:12: Transition from the UAE FIR to Bahrain East Flight Information Region [FIR]

Over head the BALUS waypoint, the aircraft transitioned from the UAE Flight Information Region [FIR] entering into the Bahrain East [FIR], with the Left Audio Control Panel [ACP] tuned to BAE-C frequency 132.12 MHz on the primary radio.

Note: BAE-C frequency is 132.12 MHz, the UAE Area Control frequency at the time was 132.15 MHz

15:13: Fire Warning Master Warning Light/Audible Alarm

One minute after passing the BALUS waypoint, approaching the top of climb, as the aircraft was climbing to the selected cruise altitude of 32,000 feet, the Fire Warning Master Warning Light illuminated and the Audible Alarm [Fire Bell] sounded, warning the crew of a fire indication on the Main Deck Fire - Forward.<sup>12</sup>

15:12:54/CVR: Audible alarm warning the crew of a Main Deck Fire Forward<sup>13</sup>

- 15:12:57|CVR|CAPT: Fire, main deck forward. alright. I'll fly the aircraft<sup>14</sup>
- 15:13:02|CVR|F.O: Okay
- 15:13:05|CVR|CAPT: Go ahead...we're gonna return

Note: Crew Resource Management [CRM]: The Captain is now the PF, the F.O is now the PNF.

---

<sup>10</sup> Pilot Non Flying or Pilot Monitoring the flight management, and carrying out support duties such as communications and checklist reading.

<sup>11</sup> All CVR excerpts are verbatim. Missing words or phrases have not been recorded on the CVR transcript.

<sup>12</sup> The smoke detectors had detected smoke in the forward main deck cargo compartment

<sup>13</sup> The fire warning bell and master fire warning light comes on when any engine, APU, main deck cargo compartment, or lower cargo compartment smoke, fire, or overheat condition is detected.

<sup>14</sup> Crew Resource Management [CRM] note: The Captain is now the PF, the F.O is now the PNF.

15:14[01]:Inflight Turn Back/Emergency Descent<sup>15</sup>

The CAPT advised BAE-C that there was a fire indication on the main deck of the aircraft, informing Bahrain ATC that they needed to land as soon as possible.

BAE-C advised that Doha International Airport (DOH) was at the aircraft's 10 o'clock position 100 nm DME<sup>16</sup> from the current location. The Captain elected to return to the point of departure, DXB.

- 15:13:14|CVR|CAPT: Just got a fire indication on the main deck I need to land ASAP
- 15:13:19|CVR|BAE-C: Doha at your ten o'clock and one hundred miles is that close enough?
- 15:13:23|CVR|CAPT: How about we turn around and go back to Dubai, I'd like to declare an emergency.

15:15[02]:Arming and Activation of the Fire Suppression System

The F.O was handling the Non Normal Checklist [NNC] checklist items, the Fire Main Deck switch was depressed and the cabin began to depressurise.<sup>17</sup>

Note: The Fire Main Deck Forward/Aft/Mid checklist on-board at the time of the accident was the pre-modified version.<sup>18</sup>

The crew changed the selected altitude from 32,000 feet to 28,000 feet as the aircraft changed heading back to DXB, the Auto Throttle [AT] began decreasing thrust to start the decent.

The AP was manually disconnected, then reconnected , followed by the AP manually disconnecting for a short duration, the captain as handling pilot was manually flying the aircraft.

Following the turn back and the activation of the fire suppression, for unknown reasons, the PACK 1 status indicated off line [PACKS 2 and 3 were off], in accordance with the fire arm switch activation. There was no corresponding discussion recorded on the CVR that the crew elected to switch off the remaining active PACK 1<sup>19</sup>.

Note: PACK 1, in fire suppression mode provides positive air pressure to the cockpit to prevent smoke/fumes from entering the cockpit area. There is no other effective smoke barrier to prevent smoke/fumes ingress into the cockpit and occupied areas.

15:15[02]:Crew Don Oxygen Masks/Intra-cockpit Communication

As the crew followed the NNC Fire/Smoke/Fumes checklist and donned their supplemental oxygen masks, there is some cockpit confusion regarding the microphones and the intra-cockpit communication as the crew cannot hear the microphone transmissions in their respective headsets.

---

<sup>15</sup> The phase of flight in which an intentionally rapid or premature descent, from a previously normal manoeuvre, is made in response to an in-flight emergency. The descent is controlled by the crew.

<sup>16</sup> DOH was the nearest airport at the time the emergency was declared (100 nm track miles). DXB was approximately 180 nm track miles from the flight position when advised

<sup>17</sup> There is no requirement for active fire suppression in Class E cargo compartments. The fire extinguishing and fire propagation mitigation is through reducing the oxygen available for combustion through depressurization of the compartment.

<sup>18</sup> Boeing MOM 1-1708015942 issued after the accident includes an advisory note to the revised non-normal checklist. Either air conditioning pack 1 or pack 3 must remain operating to prevent excessive smoke accumulation on the flightdeck

<sup>19</sup> PACK 1,2 & 3 - the PACK provides preconditioned air to the pressurised fuselage. There are 3 PACK's in the Boeing 747. When the Main Deck Cargo Fire Arm switch is depressed, PACK 2 and 3 shut down while PACK 1 continues to supply preconditioned air to the upper deck. This provides a positive pressure differential between the upper deck and the rest of the aircraft preventing smoke or fumes entering occupied areas



- 15:14:57|CVR|F.O: Can you hear me?
- 15:14:58|CVR|CAPT: No, I can't hear you.
- 12:15:17|CVR|F.O: Why can't I hear you?

This communication problem appeared to be resolved as the flight progressed.

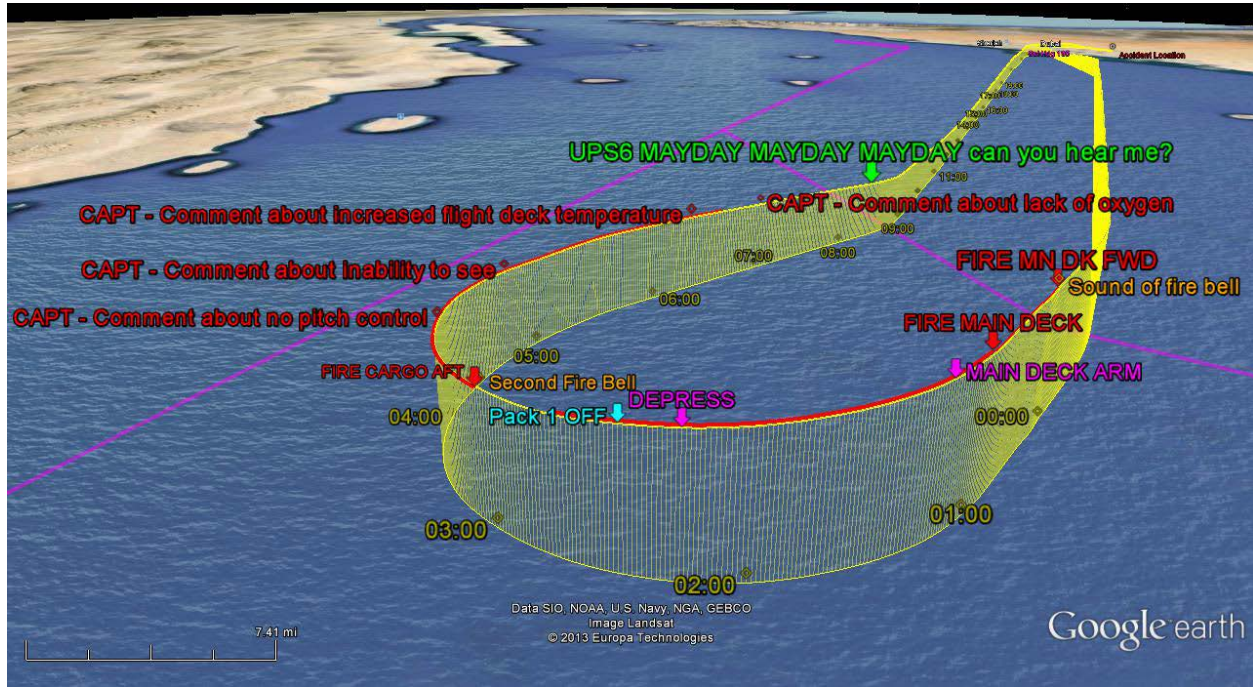

Figure 2 Inflight Turnback Fire Suppression Activation

#### 15:15 to 15:16[02]: Pitch Control Anomalies

The crew configured the aircraft for the return to DXB, the flight was in a descending turn to starboard onto the 095° reciprocal heading for DXB when the Captain requested an immediate descent to 10,000 ft.

- 15:15:23|CVR|CAPT: I need a descent down to ten thousand right away sir
- 15:15:26|CVR|BAE-C: Descend and maintain one zero thousand your discretion

The reason for the immediate descent was never clarified in the available data.

The AP was disengaged, the Captain then informed the F.O that there was limited pitch control of the aircraft when flying manually<sup>20</sup>. The Captain was manually making inputs to the elevators through the control column, with limited response from the aircraft.

- 15:15:37|CVR|CAPT: alright. I've barely got control.
- 15:15:47|CVR|CAPT: alright... find out what the hell's goin' on, I've barely got control of the aircraft.

This was followed one minute later by the following exchange:

<sup>20</sup> The Autopilot controls the elevators directly from the aft quadrant. Autopilot input to the elevator control system is received by the elevator autopilot servo control modules [ref to section 2 Analysis].

- 15:16:43|CVR|CAPT: I have no control of the aircraft
- 15:16:47|CVR|F.O: okay... what?
- 15:16:53|CVR|CAPT: I have no pitch control of the aircraft
- 15:16:57|CVR|F.O: you don't have control at all?<sup>21</sup>

The flight was approximately 4 minutes into the emergency. The aircraft was turning and descending, the fire suppression has been initiated and there was a pitch control problem<sup>22</sup>. The cockpit was filling with persistent continuous smoke and fumes and the crew had put the oxygen masks on.

15:17[04]:Smoke in the Cockpit-Reduced Visibility Due to Smoke

The penetration by smoke and fumes into the cockpit area occurred early into the emergency<sup>23</sup>. The cockpit environment was overwhelmed by the volume of smoke. There are several mentions of the cockpit either filling with smoke or being continuously 'full of smoke', to the extent that the ability of the crew to safely operate the aircraft was impaired by the inability to view their surroundings.

Due to smoke in the cockpit, from a continuous source near and contiguous with the cockpit area [probably through the supernumerary area and the ECS flight deck ducting], the crew could neither view the primary flight displays, essential communications panels or the view from the cockpit windows.

The crew rest<sup>24</sup> smoke detector activated at 15:15:15 and remained active for the duration of the flight. There is emergency oxygen located at the rear of the cockpit, in the supernumerary area and in the crew rest area. Due to the persistent smoke the Captain called for the opening of the smoke shutter, which stayed open for the duration of the flight.

The smoke remained in the cockpit area.

- 15:17:18|CAPT: UPS six we are full... the cockpit is full of smoke, attempting to turn to flight to one thirty please have...standing by in Dubai

15:18[05]:Flight Management Computer [FMC] Inputs

There was a discussion between the crew concerning inputting the DXB runway 12 Left [RWY12L] Instrument Landing System [ILS] data into the FMC. With this data in the FMC<sup>25</sup> the crew can acquire the ILS for DXB RWY12L and configure the aircraft for an auto flight/auto land approach.

The F.O. mentions on several occasions difficulty inputting the data based on the reduced visibility. However, the ILS was tuned to a frequency of 110.1 (The ILS frequency for DXB Runway 12L is 110.1<sup>26</sup>), the Digital Flight Data Recorder [DFDR] data indicates that this was entered at 15:19:20 which correlates which the CVR discussion and timing.

- 15:18:00|CVR|CAPT: Try and get Dubai in the flight management computer.
- 15:18:02|CVR|F.O: I can't see it [the FMC]

<sup>21</sup> See Section 2 – Analysis: The DFDR data indicates that there was a control column movement anomaly between the input by the crew on the control column and the travel of the elevators. The DFDR elevator data indicates nil to marginal elevator deflection while there are large deflections in column position

<sup>22</sup> The AP controls the elevators directly from the aft quadrant, the zone in the aft of the aircraft where the AP actuators are located.

<sup>23</sup> There is no cockpit door separating the cockpit area from the supernumerary area.

<sup>24</sup> The supernumerary area is immediately aft of the cockpit while the crew rest is at the back end of the upper deck.

<sup>25</sup> Sections of the FMC were recovered, however, due to the fire damage analysis of the components for non-volatile memory recorded information has not been possible

<sup>26</sup> Based on the DFDR data – See Section 2 – Analysis.

- 15:19:04 |CVR|BAE-C: UPS six expect one two left proceed direct to ah final of your discretion
- 15:19:08 |CVR|CAPT: Alright we're doing our best. Give me a heading if you can I can't see.

#### 15:20[07]:Crew Oxygen System Anomalies – Captain and First Officer

At approximately 15:20, during the emergency descent at around 21,000ft cabin pressure altitude, the Captain made a comment concerning the high temperature in the cockpit. This was followed almost immediately by the rapid onset of the failure of the Captain's oxygen supply<sup>27</sup>.

Following the oxygen supply difficulties there was confusion regarding the location of the alternative supplementary oxygen supply location. The F.O either was not able to assist or did not know where the oxygen bottle was located; the Captain then gets out of the LH seat.

This CVR excerpt indicates the following exchange between the Captain and F.O concerning the mask operation and the alternative oxygen supply bottle location. The exchange begins when the Captain's oxygen supply stops abruptly with no other indications that the oxygen supply is low or failing.

- 15:20:02 |CVR|CAPT: I got no oxygen I can't breathe.
- 15:20:12 |CVR|CAPT: Get me oxygen.
- 15:20:19 |CVR|F.O: I don't know where to get it.
- 15:20:23 |CVR|CAPT: You fly
- 15:20:41 |CVR|CAPT: I can't see

Note: the supplementary oxygen mask and the goggles on the accident flight were two separate units; when being worn by the pilot, in order to remove the mask, the goggles have to first be removed, followed by the mask. The oxygen bottle to the aft of the cockpit area is the only portable oxygen bottle with a full face mask.

At this point on the CVR, all of the associated recorded information including the conversation and ambient sounds indicate the Captain moved the seat back, got out of the seat and then moved to the aft of the cockpit area.

The Cockpit Voice Recorder [CVR] passages following the Captains decision to leave the seat and move out of the cockpit indicate that the environment was full of continuous blinding smoke, and that a breathing apparatus or protective eye wear capable of displacing smoke was required. This is the zone contiguous with the probable location of the fire breach in the cargo lining.

#### 15:22[09]:Pilot Incapacitation - Captain

Based on the pathological information, the Captain lost consciousness due to toxic poisoning.

After the Captain left the LH cockpit seat, the F.O. assumed the PF role<sup>28</sup>. The F.O. remained in position as P.F. for the duration of the flight. There was no further interaction from the Captain or enquiry by the F.O as to the location of the Captain or the ability of the Captain to respond.

#### 15:22-15:37[09-24]:Radio Communication - Relay Aircraft/Transit to DXB

The PF informed the BAE-C controllers that due to the limited visibility in the cockpit that it was not possible to change the radio frequency on the Audio Control Panel [ACP]. This visibility comment recurs frequently during the flight<sup>29</sup>

<sup>27</sup> The Captains seat is on the left hand side of the cockpit

<sup>28</sup> F.O now operating in a single pilot environment

The Bahrain East controller was communicating with the emergency aircraft via relays. Several were employed during the transition back to DXB.<sup>30</sup>

The aircraft was now out of effective VHF radio range with BAE-C<sup>31</sup>.

In order for the crew to communicate with BAE-C, BAE-C advised transiting aircraft that they would act as a communication relay between BAE-C and the emergency aircraft. BAE-C would then communicate to the UAE controllers managing the traffic in the Emirates FIR via a landline, who would then contact the destination aerodrome at Dubai, also by landline.

The crew advised relay aircraft that they would stay on the Bahrain frequency as they could not see the ACP to change frequency.

- 15:21:24|PF: Sir we're gonna have to stay with you we cannot see the radios

15:22-15:37[09-24]:Radio Communication on the Guard Frequency 121.5 MHz

The PF transmits three times on the guard frequency, at 15:35:12, 15:35:17 and 15:37:26. The transmissions cover a two minute and fourteen second period when the flight is inbound for DXB.

- 15:35:12|CVR|PF: Mayday, Mayday. UPS6, can anyone hear me?
- 15:35:17|CVR|PF: UPS 6, can you hear me?
- 15:37:26|CVR|PF: Mayday, Mayday

All of the 121.5 MHz transmissions by the PF were keyed via the VHF-R, all other radio communication with BAE-C and the relay aircraft are keyed from the VHF-L audio panel<sup>32</sup>.

There are several attempts by the UAE's Area Control [EACC] to contact the flight on the guard frequency in conjunction with aircraft relaying information transmitting on the guard frequency to the accident flight.

The PF of the accident flight does not appear to hear any of the transmissions from the air traffic control units or the relay aircraft on the guard frequency.

Around this time, given the proximity of the aircraft to the RWY12L intermediate approach fix, Dubai ATC transmits several advisory messages to the flight on the Dubai frequencies, for example DXB ARR on 124.9 MHz advise that 'Any runway is available'. The Runway lights for RWY30L were turned on to assist the return to DXB.

15:38[25]:Missed Approach to DXB Runway 12 Left

The Aircraft condition inbound as the flight approached DXB for RWY12L.

The computed airspeed was 350 knots, at an altitude of 9,000 feet and descending on a heading of 105° which was an interception heading for the ILS at RWY12L. The FMC was tuned for RWY12L, the PF

---

<sup>29</sup> Covered in Section 2. Analysis – Flight Profile

<sup>30</sup> Refer to Section 2. Analysis for further information

<sup>31</sup> The VHF radio range is limited to line of sight, so as the flight was descending and heading East away from the BAE-C FIR and the Designated Area of Coverage [DAC] for VHF radio transmission from Bahrain, the emergency aircraft and BAE-C, the radio signal strength and clarity diminish proportional to the distance away for the transmitter and the height of the aircraft above the ground. The controller managing the emergency employed several aircraft transiting the area to relay communications between BAE-C and the accident aircraft on the BAE-C frequency.

<sup>32</sup> Refer to Section 1.9 – Communications for the Boeing 747-400F Communications System Details

selected the 'Approach' push button on the Mode Control Panel [MCP] the aircraft captures the Glide Slope (G/S). The AP did not transition into the Localizer Mode while the Localizer was armed.

ATC, through the relay aircraft advised the PF, 'you're too fast and too high can you make a 360? Further requesting the PF to perform a '360° turn if able'. The PF responded 'Negative, negative, negative' to the request.

15:38[25]:Over Flight of DXB RWY 12 Left

The landing gear lever was selected down at 15:38:00, followed approximately 20 seconds later by an aural warning alarm indicating a new EICAS caution message, which based on the data is a Landing Gear Disagree Caution. At 15:38:20 the PF says: 'I have no, uh gear'.

15:39[26]:Alternate Diversion Option of Shajah International Airport [SHJ]

Following the over flight of DXB, on passing north of the aerodrome abeam RWY12L. The last Radar contact before the flight passed into the zone of silence was at 15:39:03<sup>33</sup>. The flight was on a heading of 89° at a speed of 320 knots , altitude 4200 feet and descending.

The flight was cleared direct to Sharjah Airport (SHJ), SHJ was to the aircraft's left at 10 nm, the SHJ runway is a parallel vector to RWY12L at DXB. The relay pilot asked the PF if it was possible to perform a left hand turn. This turn, if completed would have established the flight onto an approximate 10 mile final approach for SHJ RWY30.

The flight was offered vectors to SHJ (left turn required) and accepts.

- 19:38:37|PF: Sir, where are we? where are we located?
- 19:38:39|Relay: Are you able to do a left turn now, to Sharjah, its ten miles away
- 19:38:43|PF: Gimme a left turn, what heading?

The relay aircraft advised that SHJ was at 095° from the current position at 10 nm. The PF acknowledged the heading change to 095° for SHJ.

---

<sup>33</sup> A radar is not designed to detect aircraft directly above the radar antenna. This gap is known as the cone of silence.



Figure 3 DXB Overview and Track [Yellow]/SHJ location and required heading for SHJ RWY 31 localizer interception

#### 15:40[27]: Turn And Descent Followed By Uncontrolled Flight Into Terrain

For reasons undetermined the PF selected 195° degrees on the Mode Control Panel [MCP], the AP was manually disconnected at 15:40:05, the aircraft then banked to the right as the FMC captured the heading change, rolled wings level on the new heading, the throttles were then retarded, the aircraft entered a descending right hand turn at an altitude of 4000 feet, the speed gradually reduced to 240 kts.

The PF made a series of pitch inputs which had a limited effect on the descent profile; the descent is arrested temporarily. There then followed a series of rapid pitch oscillations. These were not phugoid oscillations, these were commanded responses where the elevator effectiveness decreased rapidly as the airspeed decayed and the elevators could not compensate for the reduced thrust moment from the engines to maintain level flight in a steady state. This was due to the desynchronisation of the control column inputs and the elevators.

At this point had the aircraft remained on the current heading and descent profile it would have intercepted the terrain at or near a large urban conurbation, Dubai Silicone Oasis.

The PF was in VHF communication with the relay aircraft requesting positional, speed and altitude information.

- 15:40:15|CVR|Relay: okay Dubai field is three o'clock it's at your three o'clock and five miles
- 15:40:20|CVR|PF: what is my altitude, and my heading?
- 15:40:25|CVR|PF: my airspeed?

From this point onwards, approximately 50 seconds elapse prior to the data ending.

- 15:41:33|GPWS: pull up



Figure 4 Dubai Silicon Oasis Over Flight/Accident Location, Nad Al Sheba

15:41[28]:Loss of Control Inflight followed by an Uncontrolled Descent Into Terrain – Data Ends<sup>34</sup>

The effectiveness of the pitch control immediately prior to the end of the data was negligible. The control column was fully aft when the data ended, there was no corresponding elevator movement. The aircraft lost control in flight and made an uncontrolled descent into terrain.

- 15:41:35|CVR| Data Ends

---

<sup>34</sup> A digital flight data, CVR and communications analysis of the flight profile is in Section 2 of this report.

## 1.2 Injuries to Persons

---

- 1.2.1 The accident flight crew was operating a two crew sector, the crew was comprised of a Captain and First Officer.
- 1.2.2 There were no other relief or supernumerary crew or passengers or other occupants on board the aircraft.
- 1.2.3 Neither crew member survived the accident.

<i>Injuries</i>	<i>Crew</i>	<i>Pax</i>	<i>Others</i>
Fatal	2	0	0
Serious	0	0	0
Minor/None	0	0	

Table 2 – Injuries (Fatal) to Persons

## 1.3 Damage to the Aircraft

---

- 1.3.1 The aircraft – airframe, systems and available living space - were subject to significant thermal loading caused by fire, resulting in material degradation and damage. This resulted in the exposure of primary structural elements, components and assemblies to significant heat damage and the cockpit area to continuous smoke and toxic fume penetration resulting from the on-board cargo fire.
- 1.3.2 The fire severely damaged significant systems leading to failures in aircraft controllability and crew survivability systems, failures which interfered with the normal flight management, directly with the aircraft controls and the crew supplementary oxygen system supply.
- 1.3.3 The aircraft was completely destroyed by the ground contact followed by a post-accident fire.

## 1.4 Other Damage

---

- 1.4.1 The aircraft contacted several street lamps on the perimeter of the Nad Al Sheba Military base during the uncontrolled descent.
- 1.4.2 The first ground contact was a service road with the aircraft in a right-hand wing down nose low attitude.
- 1.4.3 The right-hand wing struck several buildings and vehicle parking stands before progressing through a line of maintenance storage buildings immediately prior to the forward fuselage contacting an elevated sand bank and additional support buildings in the general vicinity ahead of the aircraft.

## 1.5 Personnel Information

---

### 1.5.1 Flight Crew Information

The accident flight crew consisted of a Captain and a First Officer. There were no passengers or supernumerary crew occupying the aircraft jump seats or supernumerary positions.

The flight crew were licensed and qualified to operate the flight in accordance with existing regulations, medically fit and adequately rested in compliance with the fatigue regulations in place at the time of the accident.



### 1.5.2 Scheduling

Both the Captain and F/O began the pairing from their crew base in Anchorage, Alaska (ANC) on August 30, 2010, by jump seating on a flight from ANC to Hong Kong (HKG) via Seoul Incheon Airport (ICN). While on a layover in HKG for 47:44 hours (8/31 – 9/2), they stayed at the Hyatt Regency, Hong Kong, Sha Tin.

Following the layover in HKG, both crewmembers operated UPS flight 6 from HKG-DXB on September 02, 2010. The flight time for HKG to DXB was 7 hours and 51 minutes, and according to UPS records, the crew was on duty for 9 hours and 51 minutes. Both crewmembers had a 24:29 hour layover in DXB at the Fairmont Dubai, Sheik Zayed Road.

The crew was scheduled to operate UPS flight 6 on September 3, 2010 from DXB to Cologne, Germany (CGN), followed by a 55 hour rest period.

### 1.5.3 The Captain

The Captain was 48 years old and his date of hire with the operator was July 10, 1995. He had flown for several commuter airlines, and previous to UPS was furloughed from US Airways. A search of FAA records indicated that he had no accidents, incidents, or violations in aviation and no record of any investigations pending.

Captain's Pilot Certificates and Ratings Held at Time of the Event:

- Airline Transport Pilot (issued November 7, 2009)
- Aircraft Multiengine Land A310; B-747-400; B-747, Commercial Privileges Aircraft Single Engine Land, English Proficient; A-310; B-747-400; B-747 Circ. Apch. -VMC Only.

MEDICAL CERTIFICATE FIRST CLASS issued March 3, 2010

Limitations: None

Captain's Training and Proficiency Checks Completed:

- Initial Type Rating B747-400: April 11, 2005
- Last recurrent Proficiency Check: November 7, 2009
- Last recurrent ground training: November 1, 2009
- Last Line Check in B747-400: December 2, 2009 (ANC-SDF)

Captain's - Flight Hours	
Total pilot flying time	11,200 hours
Total Pilot-In-Command (PIC) time	2,350 hours
Total B747-400 flying time	4053.4 hours
Total B747-400 PIC time	1218.7 hours
Total flying time last 24 hours	0 hours
Total Flying time last 7 days	9.9 hours
Total flying time last 30 days	50.1 hours

Total flying time last 60 days	77.7 hours
Total flying time last 180 days	209.7 hours
Total flying time last 12 months	370.7 hours

Table 3 The Captain's flight times

#### 1.5.4 The First Officer

The First Officer was 38 years old and was hired by the operator on June 20, 2006. He had been previously employed by Chautauqua Airlines.

A search of FAA records indicated that he had no accidents, incidents, or violations in aviation and no record of any investigations pending.

#### The F/O's Pilot Certificates and Ratings Held at Time of the Event

- Airline Transport Pilot (issued June 6, 2010)
  - Aircraft Multiengine Land B-747-4, B-757, B-767, EMB-145; Commercial Privileges Aircraft Single Engine Land; B-747-4, B-757, B-767 Circ. Apch. – VMC Only.
- Aircraft Single Engine and Multiengine Instrument Aircraft

Medical CERTIFICATE Second Class (issued May 4, 2009).

- Limitations: None.

#### The F/O's Training and Proficiency Checks Completed

- Last Proficiency check on B747-400: June 24, 2010
- Last recurrent ground training: June 20, 2010
- The F/O's Flight Times

First Officer – Flight Hours	
Total pilot flying time	5,549 hours
Total PIC time	1,590 hours <sup>35</sup>
Total second in command (SIC) time	1,355.3 hours
Total flying time in B747-400	77.4 hours
Total B747-400 second-in-command (SIC) time	77.4 hours
Total flying time last 24 hours	0 hours
Total Flying time last 7 days	9.9 hours
Total flying time last 30 days	25.9 hours

---

<sup>35</sup> PIC time derived from previous carrier (Chautauqua Airlines) flight times and resume

Total flying time last 60 days	77.4 hours
Total flying time last 180 days	130.2 hours
Total flying time last 12 months	243.3 hours

Table 4 The First Officer's flight times

## 1.6 Aircraft Information

### 1.6.1 General Aircraft Information



Figure 5 B747-44AF Cockpit Layout

The accident aircraft was a Boeing 747-44AF, registration number N571UP, serial number 35668. It was manufactured in 2007 and received its airworthiness certificate on September 26, 2007.

This aircraft is certified under Federal Aviation Authority 14 CFR PART 25—Airworthiness Standards: Transport Category Aircraft.

The aircraft was registered to the United Parcel Service in Louisville, Kentucky.

The aircraft was powered by four General Electric CF6-80C2-B5FG01 engines.

Aircraft Type	Boeing 747-44AF
Block Number	RL562
Serial Number	35668
Line Number	1393
Engines	General Electric CF6-80C2-B5FG01
Basic Operating Weight	352,000 lbs
Passenger Weight	0000 lbs
Baggage & Cargo	228,076 lbs
Zero Fuel Weight	580,076 lbs
Fuel	193,693 lbs
Ramp Weight	773,769 lbs
Maximum Ramp Weight	878,000 lbs
Taxi Fuel Burn	2,700 lbs
Take-off Weight	771,069 lbs
Maximum Take-off Weight [Landing Limit]	801,100lbs.
Maximum Certificated Take-off Weight	875,000 lbs.
Maximum landing weight	652,000 lbs.

Table 5 Accident flight operators dispatch release information

## 1.6.2 Mass and Balance

### Limitations

The aircraft mass and the centre of gravity of the aircraft were within the prescribed limits.

Center of gravity shift in flight: the center of gravity at the time of the accident could not be determined to establish if the destruction by fire of a significant portion of the cargo forward of the Mean Reference Chord [MRC] had a significant effect on the handling or the control and stability of the aircraft

### 1.6.3 Body Stations [STA].

This report contains numerous references to the aircraft's Body Stations. These are a true measure in inches from the following reference datums.

The STA reference is a vertical plane perpendicular to the body centerline, located 90 inches forward of the aircraft nose.

The WL reference is a horizontal plane located 91 inches below the lowest body surface.

The RBL and LBL reference is a vertical plane on the body centerline.

The naming convention is STA [body station] followed by the distance from the reference datum 'STA 464' for example is the forward cargo hold forward bulkhead location. 464 inches from the reference datum 90.0 inches forward of the aircraft nose.

## General Arrangement

The following aircraft profile illustrates cargo compartment locations/Body Stations. The factual information text in other sections of this report uses the body station reference system to identify positions on the aircraft based on this reference system.

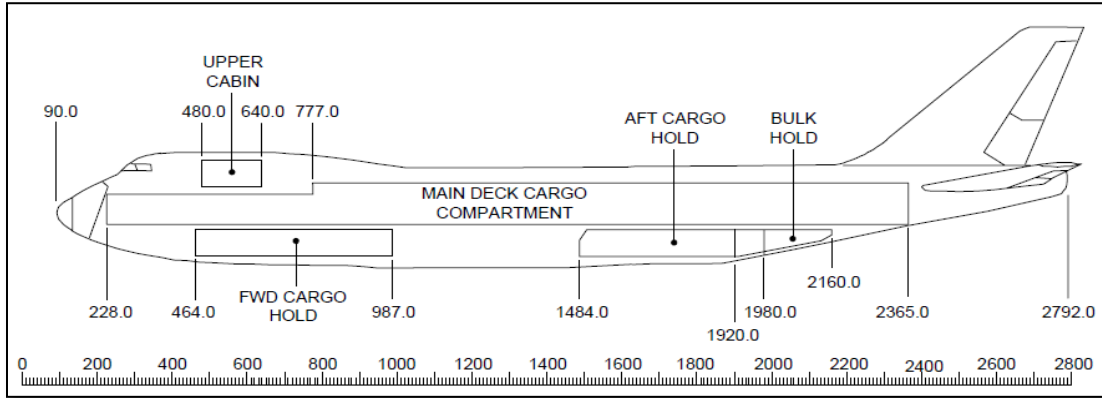

Figure 6 Body Stations Reference System

### 1.6.4 Boeing 747 Class E Cargo Compartment

Class E cargo compartments are certified for cargo aircraft only. There is a separate approved smoke or fire detector system to give warning at the pilot or flight engineer station. There are means to shut off the ventilating airflow to, or within, the compartment, and the controls for these means are accessible to the flight crew in the crew compartment.

There are means to exclude hazardous quantities of smoke, flames, or noxious gasses from the flight crew compartment. The required crew emergency exits are accessible under any cargo loading condition

Cargo Liners in Class E Cargo Compartments.

Liners are a passive fire protection feature. The primary purpose of a cargo liner is to prevent a fire originating in a cargo compartment from spreading to other parts of the airplane before it can be brought under control by the fire suppression system

Cargo compartment flame resistance test requirements specify that a minimum of three specimens must be tested; there must be no flame penetration of any specimen within five minutes after application of the 1,700 degrees F (927 degrees C) flame source; and for ceiling liners, the peak temperature measured at four inches above the upper surface of the horizontal test panel must not exceed 400 degrees F (202.4 degrees C). All other materials must be self-extinguishing.



## B747-400 FREIGHTER

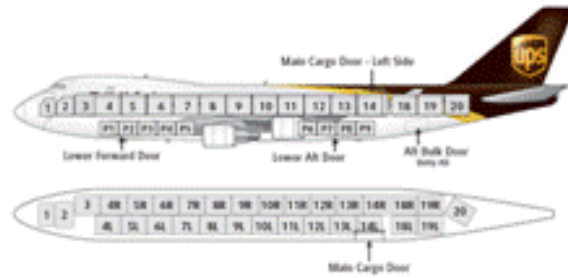

Figures 7- Main Deck Class E Cargo Compartment, looking aft/Pallet and container locations

### 1.6.5 Performance

No performance limitations have been identified for the initial phase of this flight. All envelope limitations for the routine take off and climb appeared to be normal, i.e. engine power was normal, speed, rate of climb are with the normal ranges

### 1.6.6 Instrument Landing System – Description

#### General

The instrument landing system (ILS) is a navigational aid that provides aircraft position data for landing approaches. It is designed to receive and process localizer (LOC) and glide slope (G/S) ground station transmissions and provide output to interfacing systems for display and navigational use.

The ILS receiver is a module within the Multi-Mode Receiver (MMR).

The ILS has three independent subsystems designated as the left, right and center ILS. Each subsystem contains an ILS receiver, VOR/LOC antenna input, LOC antenna, G/S capture antenna, G/S track antenna, VOR/LOC antenna switch, G/S antenna coaxial relay, and VOR/LOC power divider(s).

The ILS receivers are normally tuned automatically by the flight management computers (FMC) or they can be tuned manually using any of the three control display units (CDU). Ground station information of the tuned frequency is provided by the VOR/LOC or LOC antenna, and the G/S capture or G/S track antenna.

### 1.6.7 Crew Alerting – Fire

The crew alerting system when smoke is detected will alert the crew with the master fire light, fire bell, warning, and status EICAS messages.

For the main deck compartment on the 747-44AF, the message “FIRE MN DK FWD,” “FIRE MN DK MID,” or “FIRE MN DK AFT” will be displayed on the EICAS to identify the affected area within the main deck compartment. The EICAS warning message “FIRE MAIN DECK” is displayed if smoke is detected in more than one zone of the main deck cargo compartment.

The smoke detection systems give the flight crew visual and/or aural indications of abnormal conditions in the main deck compartment and lower cargo compartments.

The generated signal will create master fire warning light, fire bell, warning and advisory EICAS (engine indicating and crew alerting system) messages. The fire warning bell sound comes from two multi-

purpose speakers in flight deck. The master fire warning light indicators are located above the captain and first officer's main instrument panels.

### 1.6.8 Oxygen System

#### Crew and Portable Oxygen System Description

The flight crew supplemental oxygen system provides gaseous oxygen to the flight crew during normal operational procedures, in the event that the cabin is inadvertently depressurized as the result of a system or structural failure, or is intentionally depressurized as part of controlling a fire in the main deck Class E cargo compartment.

The 747-400F Crew Oxygen System consists of high pressure bottles of gaseous oxygen, pressure regulators to transition high bottle pressures to lower pressure, distribution lines to transport oxygen from the bottles to the flight deck, and individual crew oxygen masks and mask storage boxes located at the captain, first officer, and observer stations. The flight crew masks are diluter-demand, oro-nasal masks (covering the nose and mouth) designed for rapid donning in the event of a depressurization to prevent incapacitation of the flight crew due to hypoxia. If smoke or fumes are present, eye protection is provided by separate smoke goggles which can be donned and which can be interfaced with the oxygen mask to blow oxygen from the mask into the goggles to clear smoke from the goggles. Oxygen flow to each individual oxygen mask is controlled by a regulator mounted on the mask.

The aircraft is equipped with a separate supernumerary (passenger) oxygen system, but as there were no supernumeraries or passengers on the accident flight, this is omitted from the report.

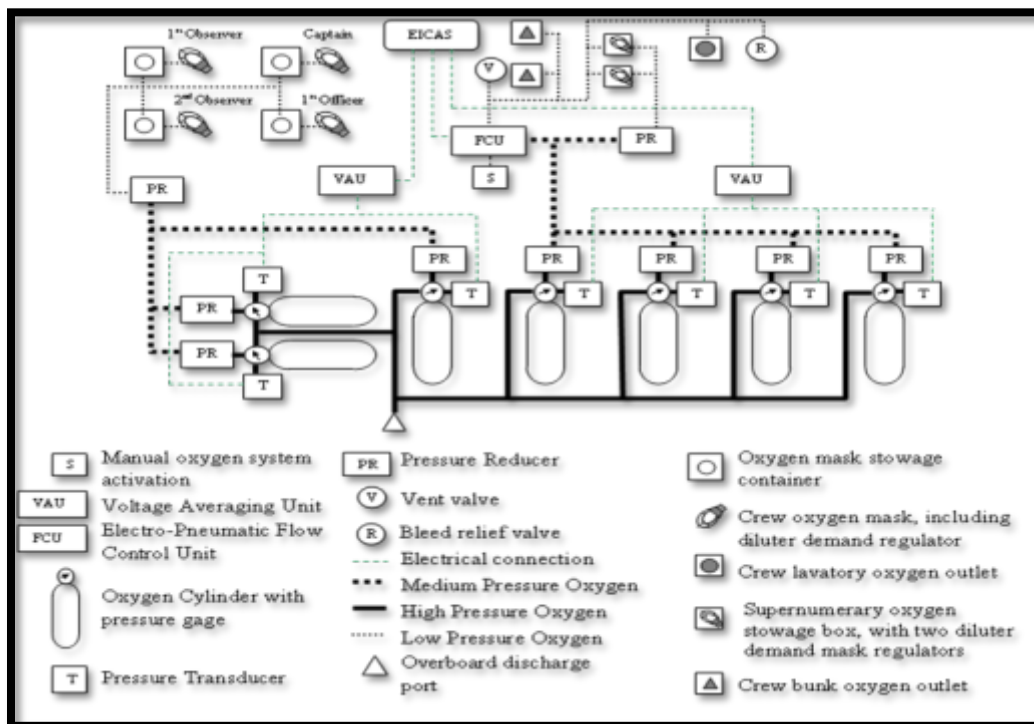

Figure 8 - Crew Oxygen System Schematic

Portable oxygen bottles with masks and other emergency equipment are provided in the flight deck and supernumerary area for use, as needed. The accident aircraft was equipped with five portable oxygen cylinders, one located in the cockpit, and four portable bottles in the supernumerary: one on the wall,

one in the lavatory, and two in the separate sleeping quarters. The portable bottle located in the cockpit was the only portable unit that had a full face mask.

### 1.6.9 Crew Oxygen Bottle Installation

There are three crew oxygen bottles installed on the right sidewall of the forward cargo compartment, just aft of the cargo door at approximately station 680 – 720 (Figure 7). Two forward bottles are mounted horizontally and the aft bottle is mounted vertically. Each bottle, when full (1850 psi @ 70degrees F), contains approximately 3000 liters of useable oxygen. At the outlet of each bottle is a frangible disc safety release device, and a manual shutoff valve. At the outlet of the manual shutoff valve is a pressure transducer, and a high-pressure regulator (pressure reducer).

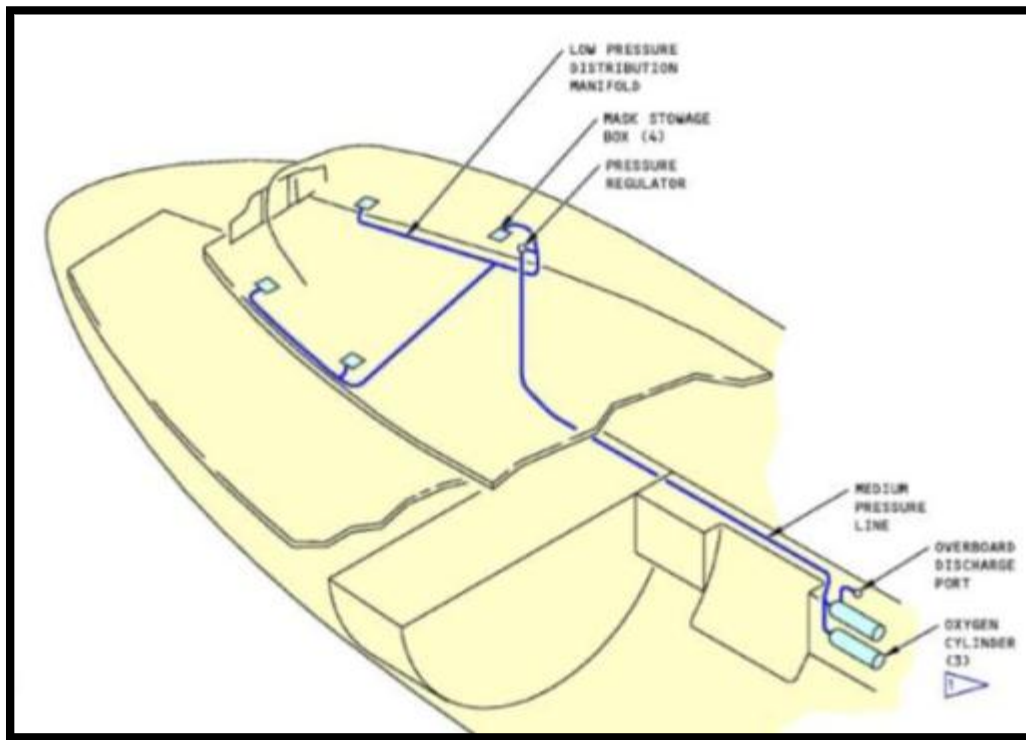

Figure 9 Crew Oxygen Bottle Location

The frangible disc safety release device will rupture when the bottle pressure is between 2500 and 2775 psig. This will allow the oxygen to escape into an overboard discharge line, emptying the bottle. Boeing estimated that this will occur if the bottle exceeds 94°C/ 200°F for a full bottle described above.

The high-pressure regulator reduces the bottle pressure to an intermediate system pressure of approximately 600-680 psig.

### 1.6.10 Oxygen Distribution To The Flight Deck

The distribution of oxygen from the bottles to the flight deck is primarily provided through corrosion resistant steel (CRES) 21-6-9 tubes, except there are short flex hoses at the output of the high-pressure regulator on the two forward bottles. The three outputs from the high-pressure regulators are connected together near the bottles to form one distribution tube. This tube is routed forward along the right sidewall, below the main deck, from station 680 to station 380. The tube is then is routed up the right sidewall to the flight deck floor. It turns forward and is then routed up to the low-pressure



regulator, located about 30 inches above the flight deck floor at STA 365, near the first observer's position. The output of the low pressure regulator enters a T-fitting, one side is connected to a flexible hose which connects to the first observer's oxygen mask stowage box, the other side, to a tube which travels down to the floor and forward to Station 340. Here the tube enters another T-fitting, with one side routed forward to station 300 where it connects to a short flex hose to the first officer's oxygen mask stowage box, and the other travels across the floor beam to the left side of the flight compartment floor. On the left side, the tube enters another T-fitting, with one side connecting outboard and up to a flexible hose which attaches to second observer's oxygen mask stowage box, the other tube goes forward to station 300, where it goes up and connects to a short flex hose to the captain's oxygen mask stowage box.

The low-pressure regulator reduces the intermediate system pressure of 600 - 680 psig to 60 – 85 psig. The regulator has a pressure relief valve for the output, set at 100 – 110 psig.

The flexible hoses which connect directly to the oxygen stowage boxes have an inner tube made of EP14 PVC with a Nomex green cover and 302 CRES supporting spring.

#### 1.6.11 Crew Alerting – Crew Oxygen Low Warning

A voltage from each pressure transducer is sent to a voltage averaging unit, installed near the bottles. The voltage averaging unit determines the average voltage and sends that information to the EICAS display. The EICAS display converts the value to a system pressure and displays the information to the flight crew on the EICAS STATUS page. If the system pressure drops below 500 psi, the EICAS will generate a "Crew Oxy Low" advisory message.

#### 1.6.12 Oxygen Stowage Box (MXP147-3) and Masks

Each mask has two red harness inflation levers, that when squeezed, allow the mask to be removed from the stowage box and inflates the mask harness. Releasing the levers after placing the mask over the head, deflates the mask harness, fitting it securely to the head and face. The action of removing the mask opens both stowage box doors, and the left-hand door opening allows oxygen to flow to the mask and to a pressure switch in the box which activates the microphone in the mask. The pressure switch activates at 33 +/- 4 psi.

An OXYGEN ON flag appears in the mask compartment near the left-hand door of the stowage box, indicating the oxygen supply valve is open. The oxygen flow can be shut off by closing the left-hand door of the stowage box and pushing and releasing the RESET/TEST switch. This action shuts off oxygen to the mask, stows the flag, deactivates the mask microphone, and activates the boom microphone. The oxygen system can be reactivated by opening the left-hand door of the stowage box. A yellow cross shows in the flow blinker when oxygen is flowing to the mask.

#### 1.6.13 Oxygen Masks Operation

The oxygen mask/goggle sets available to the UPS6 flight crewmembers were diluter-demand oxygen masks<sup>36</sup> with mask-mounted regulators. This type of mask, which is common for air carrier operations with pressurized cabins, has two selectable regulator switches. The first is the normal/100% oxygen switch. When set to Normal, the wearer receives a mix of pure oxygen and ambient air depending upon the cabin pressure altitude (the higher the cabin pressure the more pure oxygen). When set to 100% the wearer receives pure oxygen regardless of cabin altitude. The second is the Press-to-test/Emergency

---

<sup>36</sup> Diluter-demand oxygen masks supply oxygen only when the user inhales through the mask.

knob. When set to Emergency, the wearer receives a constant overpressure of pure oxygen. Separate goggles were provided for smoke and fire conditions requiring eye protection. Donning an oxygen mask/goggle set involves removing the mask from the stowage box, inflating the harness, installing the harness on the head, adjusting the mask as required, removing the smoke goggles from their container, and securing the goggles over the head and on top of the oxygen mask.

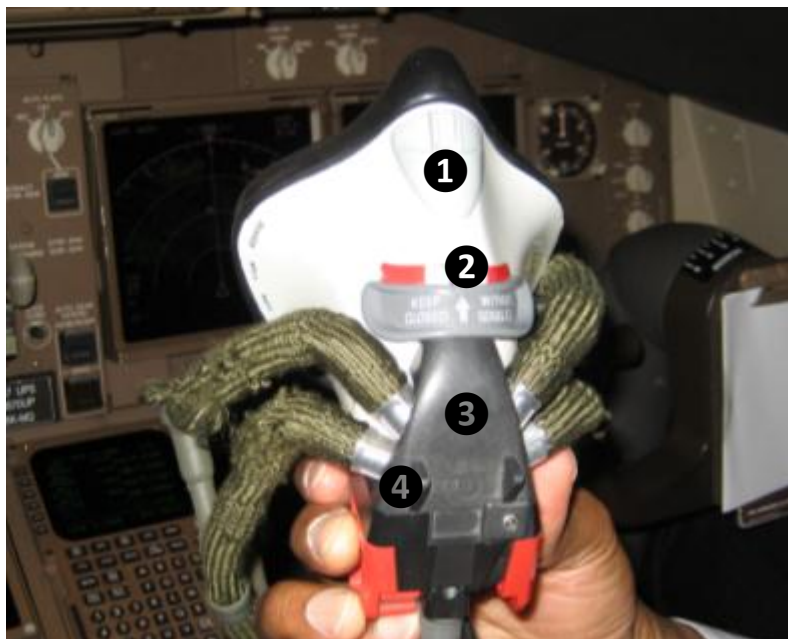

- ❶ Oxygen Mask
- ❷ Goggle Vent
- ❸ Internal Microphone
- ❹ Oxygen Regulator

Figure 10 Flight crew oxygen mask.

Flight crewmember oxygen masks have two purposes. First, during a cabin depressurization event, the mask provides supplemental oxygen to protect pilots from the effects of hypoxia.<sup>37</sup> The second purpose of the mask is to provide protective breathing at 100% oxygen during a smoke, fire, or fumes event. For the oxygen mask to be a fully compliant protective breathing device as defined in 14 CFR 121.337(b)(7),<sup>38</sup> the mask must be set to 100% and the regulator set to the emergency setting. In addition, the goggles must be donned, and the smoke vent selector on the mask must be opened to vent the goggles of any smoke<sup>39</sup>. When the oxygen mask/goggle set is donned, the locations of the normal/100% switch and the emergency selector on the regulator, in addition to the smoke vent

<sup>37</sup> According to the FAA's *Pilot's Handbook of Aeronautical Knowledge*, FAA-H-8083-25A, Chapter 16, "Aeromedical Factors," hypoxia means "reduced oxygen," or "not enough oxygen." Although any tissue will die if deprived of oxygen for a period of time, the brain is particularly vulnerable to oxygen deprivation; any reduction in mental function while flying can result in life-threatening errors. Symptoms of hypoxia commonly include headache, decreased reaction time, impaired judgment, euphoria, visual impairment, and drowsiness.

<sup>38</sup> Title 14 CFR 121.337(b)(7) states, in part, the following: "(i) The equipment must supply breathing gas for 15 minutes at a pressure altitude of 8,000 feet for the following: (A) Flight crewmembers while performing flight deck duties; and (B) Crewmembers while combating an in-flight fire. (ii) The breathing gas system must be free from hazards in itself, in its method of operation, and in its effect upon other components."

<sup>39</sup> According to the Boeing 747-400 Flight Crew Operating Manual (FCOM), pages 1.30.28 and 1.30.29, the "up" position indicates that the vent valve is closed. The "down" position indicates that the vent valve is open, allowing oxygen flow to the smoke goggles.

selector on the mask, are not visible to the pilot and, therefore, must be located and activated only by feel.

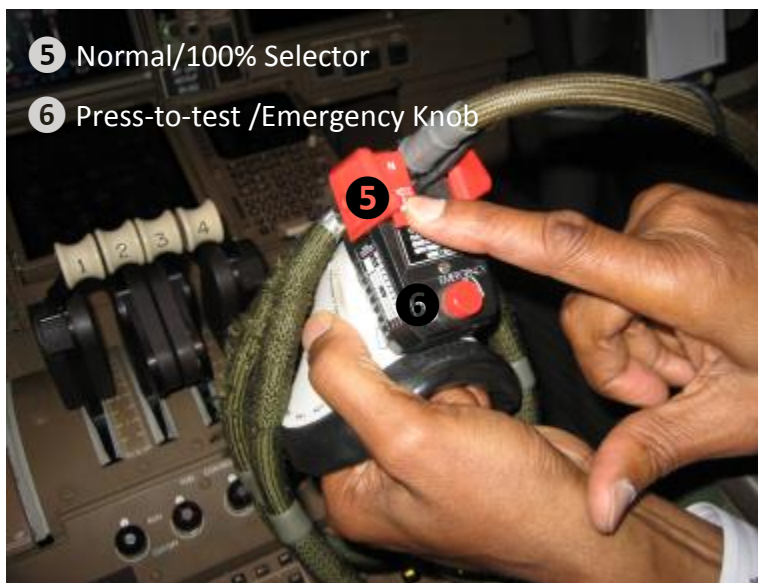

Figure 11 - Location of Normal/100% switch and Press-to-test/Emergency knob.

#### 1.6.14 Oxygen Mask Details

##### Accident Aircraft Oxygen Mask Information

The crew oxygen masks installed in the accident aircraft were Intertechnique part number MC10-25-104, serial numbers 58494, 73675, 73676, and SE13332. According to Boeing delivery records, serial number 73675 was installed in the captain's position and serial number 58494 was installed in the First officer's position.

There were no masks or mask stowage boxes identified in the wreckage.

##### Oxygen System Operation/Performance

This section lists some of the facts, evidence, and conditions related to the oxygen system performance on the day of the accident. This information was gathered from the CVR, FDR, Operations, and Systems group efforts for this investigation. This section serves a summary of the investigative efforts related to the oxygen system performance. The information below is consistent with oxygen system continuity (pressure) at the following locations:

- i Between the oxygen supply cylinders and the high pressure regulator
- ii At the Captain's mask stowage box manifold, and
- iii At the inlet to the Captain's oxygen mask.

### 1.6.15 Mask Stowage Box [MXP147-3] Location



Figure 12 Captains Mask Stowage Location

#### Captains [LH] Mask Stowage Box:

A mask stowage box is located at each crew station. The box provides stowage for the mask/regulator and controls flow of oxygen to the mask/regulator. The box contains a sliding control, a shutoff valve, left and right lids and a flow blinker.

#### Mask Regulator Assembly

A mask/regulator assembly is provided at each crew station. A mask/regulator is stowed in each mask stowage box.

The mask/regulator contains an oxygen mask with a microphone, an inflatable harness, and a diluter demand regulator.

#### Mask Operation - Normal Mode

When the mask/regulator is taken out of the mask stowage box, opening of lid releases the shutoff valve piston and allows the valve to open.

After the mask/regulator has been taken out of the mask stowage box, the lids can be closed without shutting off the pressure supply to the regulator. When closing the left-side lid, the inner part of the sliding control rotates and shows the white flag marked OXY-ON.

With the regulator set in the NORM position the regulator provides an automatic oxygen dilution. At lower altitudes, ambient air is allowed to enter the regulator and mix with the added oxygen. As the cabin altitude increases, the percentage of air entering the regulator is reduced until 100% oxygen is supplied to the mask.

With the regulator set in the NORM position the regulator provides an automatic oxygen dilution.

At lower altitudes, ambient air is allowed to enter the regulator and mix with the added oxygen. As the cabin altitude increases, the percentage of air entering the regulator is reduced until 100% oxygen is supplied to the mask.

#### Mask Operation - 100 Percent Oxygen Mode

With the mask/regulator being donned by the user, moving the oxygen dilution control to 100 percent and rotating the PRESS TO TEST knob to the normal (non-emergency) position provides a supply of pure oxygen to the user. Flow to the user is controlled on a demand basis by normal

breathing. The 100% mode provides 100% oxygen on demand regardless of cabin altitude.

#### Mask Operation - Emergency Mode

With the mask being donned by the user, moving the oxygen diluter lever to 100 percent and rotating the PRESS TO TEST knob to EMERGENCY provides a positive flow of pure oxygen to the user. In this mode, flow to the user is not controlled by user's inhalation cycle.

The EMER mode, like the 100% mode supplies the mask with 100% oxygen regardless of altitude. In addition, oxygen is supplied at a slight positive pressure. This emergency safety feature prevents toxic gas and contaminants from entering the mask by providing a positive pressure seal.

### 1.6.16 Environmental Control Systems

#### Air Conditioning Packs

Positive pressure supplied by one pack is used to reduce the effect of smoke in the cockpit and supernumerary area after the fire suppression sequence has been activated.

The failure of the remaining pack [Pack 1] occurred just after the fire main deck warning switch had been depressed.

Three identical air conditioning packs cool bleed air from the engines, APU, or high pressure air from a ground source. Bleed air is precooled before entering the pack. The packs are controlled by two identical pack temperature controllers (PTCs), A and B. Each PTC has three separate channels, one for each pack.

Due to the severity of the fire damage and the probable damage to the ECS ducting adjacent to the pulley trusses, it is unlikely that the pack, had it been operational, would have functioned as intended regardless of the operational status.

Note: The ECS ducting material is Polyisocyanurate, per BPS-D-124

### 1.6.17 Air Conditioning and Pressurization

When a PACK Control selector is placed in NORM, A, or B, the respective pack valve opens, which allows bleed air to flow into the pack. The pack valve is controlled electrically by the PTC and opens by bleed air pressure.

Each pack valve has two flow settings, normal and high. During cruise, normal flow minimizes bleed air demand on the engine to reduce fuel consumption. Fuel consumption is reduced approximately 0.3% for each pack in normal flow.

In cruise, pushing the Pack High Flow switch to ON will configure all three packs to high flow.

#### Pack Non-Normal Operation

Pack control, fault detection, and overheat protection are all automatic.

### 1.6.18 Fire Suppression

The freighter main deck has fire suppression procedures which conform to FAA class 'E' compartment requirements and the established Boeing fire suppression procedures.

Following smoke detection, air inflow shut-off is accomplished. The aircraft descends or ascends to 25,000 feet altitude. The guarded fire suppression "DEPRESS/DISCH" switch initiates a depressurization of the entire aircraft at a rate of approximately 9,000 feet/per/min to a final cabin pressure of 25,000 feet.

The cabin is depressurized to a slightly higher pressure than ambient to ensure the negative pressure relief valves are shut during the steady state fire suppression mode. The ambient oxygen content, pressure and temperature conditions are reduced at 25,000 feet altitude as compared to lower altitude conditions. When the main deck arming switch is selected, two packs automatically shut down. The remaining pack reconfigures to reduced flow, supplying air to the upper deck for ventilation and flight deck instrument cooling only. All valves providing airflow to or within the main deck and lower lobe cargo compartments are commanded closed. Electronic equipment E/E cooling configures to closed loop.

#### 1.6.19 Lower Lobe Cargo Compartment Fire Protection Systems

##### Smoke Detection

The forward lower cargo compartment has eight smoke detectors, and the aft compartment has eight smoke detectors. Each smoke detector has a beacon lamp which supplies a smoke (fire) indication to flight crew when smoke is present in the air. The flight crew will be notified of fire and fault condition by master fire light, fire bell, warning, and status EICAS messages.

##### Fire Suppression

The lower cargo compartment fire extinguishing system is designed to fill the forward or aft cargo compartment with a fire extinguishing agent when smoke is detected. The system is electrically controlled by switches on the P5 pilot's overhead panel.

#### 1.6.20 Flight Deck Smoke Evacuation Shutter

The smoke shutter attaches to the fuselage structure above the flight compartment door. The pilots use a tee handle to open and close the smoke shutter in case of smoke in the cockpit. The tee handle is between the P7 Overhead Circuit Breaker Panels.

The tee handle attaches to a cable which attaches to the smoke shutter.

The shutter assembly is installed on the aft control cabin ceiling. The smoke shutter function is to remove the smoke from the flight compartment of the aircraft.

#### 1.6.21 Flight Control Systems

##### General:

Control cables in the flight control system transmit the pilots' control inputs to the corresponding control surface actuators.

The cables and assemblies are rigged to a given tension. This tension in the complete control cable assembly transmits the commands to the control surfaces. Any reduction in the cable tension has a retrograde effect on the control movement and a dissymmetry between the control inputs and the control surface movement will occur reducing the aerodynamic effect required to command responses from the aircraft. This was noticed as desynchronisation by the crew of the accident flight.

To understand the relationship between the control tension reduction, the effect of the fire on the cable truss and the control of the aircraft, the following technical description details the control systems and the control effectiveness.

##### Background information:

The first indication that there was a controllability problem was within three minutes of the main fire warning when the crew disengaged the AP electing to control the aircraft manually.

The ineffectual flight control response with the AP disengaged appears in the DFDR data as a control anomaly and as crew statements on the CVR on multiple occasions.

The significance of the controllability problems become apparent in the later stages of the event sequence.<sup>40</sup>

A review of the flight data recorder information for the accident flight indicated anomalies with the operation of the elevators, rudders, speed brakes, landing gear, and brakes: all of these are primarily controlled through cables that run from the cockpit through a suspended truss system at the rear or the supernumerary area of the aircraft.

This section documents the general operation of these systems, the cable routing, and also describes the anomalies found in the flight data.<sup>41</sup>

---

<sup>40</sup> The compound problems of cockpit visibility and the inability to view the warning and alerting system are covered in another section of this report .

<sup>41</sup> Refer to Section 2. Analysis for the detailed Flight Profile and Flight Controls analysis.

### 1.6.22 Control Cables

Control cables in the flight control system transmit the pilots' control inputs to the corresponding control surface actuators. A typical control cable system terminates at a drum or quadrant by means of swaged terminals and has turnbuckles to allow tensioning the cable to the proper rigging load. Long cable runs are supported by idler pulleys.

The control cables for the elevators, rudders, speed brakes, landing gear, and brakes are routed under the flight deck and then up into the crown of the airplane where they are supported by two large cable pulley trusses (Figures 3 and 4). They all continue aft along the crown. The cables for speed brakes, landing gear, and brakes go down near the wheel well area, and the cables for elevator and rudder continue aft in the crown to the tail.

Control cables for ailerons/spoilers are routed under the flight deck a short distance and then down to the lower cargo compartment ceiling and aft to the wing rear spar, down through air pressure seals in rear spar canted bulkhead to the aileron quadrants, and spoiler differential mechanism.

### 1.6.23 Control Cable Truss and Pulley Routing

The pulley bracket truss assemblies are located aft of the supernumerary area near body station 800, suspended from the overhead fuselage by a series of brackets.

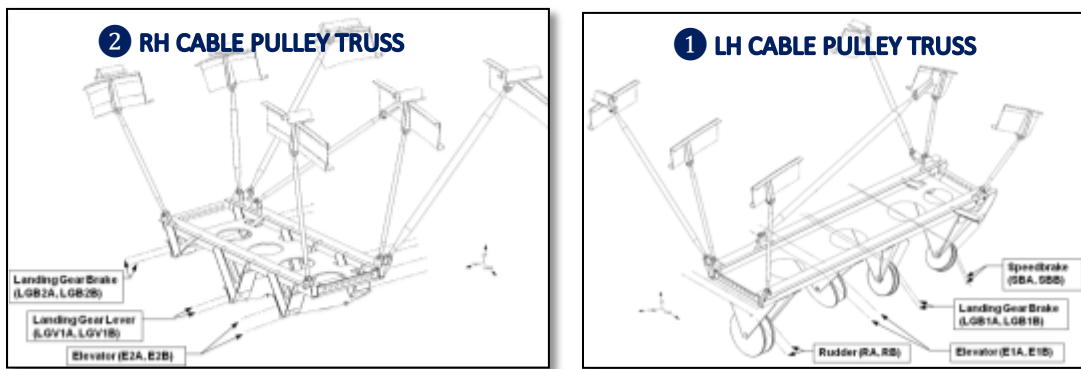
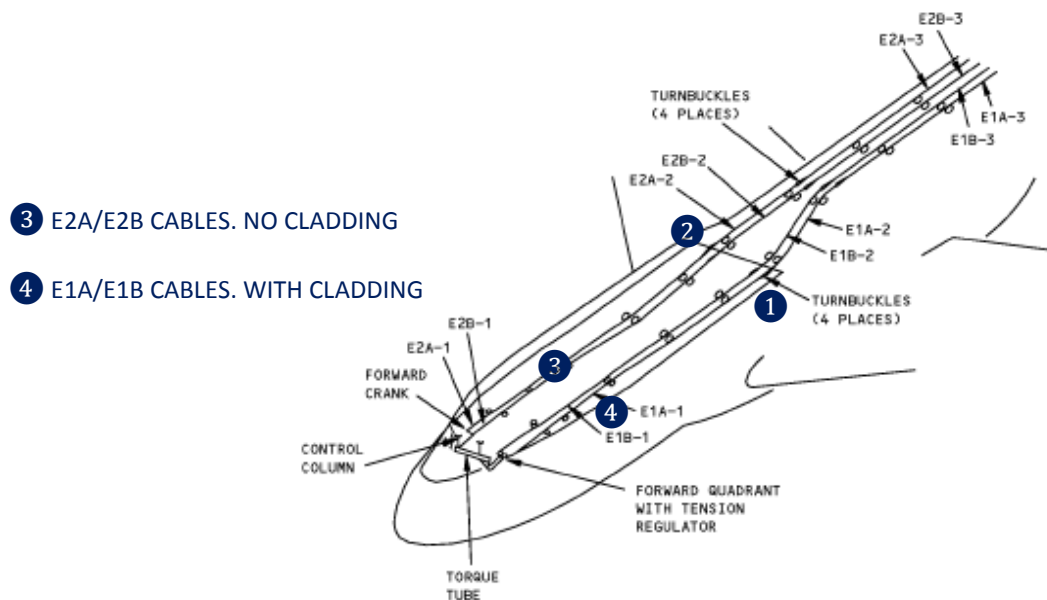

Figure 13 Cable Truss and Pulley Routing Left and Right





The truss lower section is a rectangular aluminium assembly with a series of V brackets, each bracket supports a circular pulley wheel. The Steel control cables run through the pulley wheels.

The truss assembly is composed of aluminium 2024-T3, T42 (Brackets, Tie Rods) 7075-T73 (Pulleys, Tie Rod Fittings).

The control cables are fabricated from the following materials, Control Cable: 1070 Carbon Steel / Control cables are thin strands of tinned carbon steel. Some control cables, for example the Captains [LH] E1A/E1B elevator cables, have a cable cladding manufactured from 6061-T4, -T6 Aluminium. According to the manufacturers information, the cladding is for increased stiffness and does not have a damage tolerance function

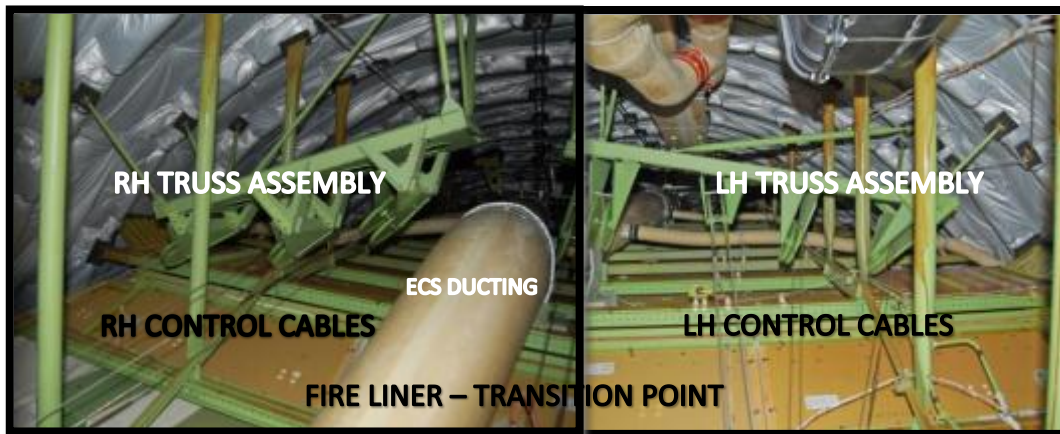

Figure 14 Left and Right Pulley Bracket Truss – Upper Crown Area/View Looking Aft

#### 1.6.24 Control Cable Truss Assembly Material Properties – Heat

Control Cable Truss Assembly Material Properties - Heat	
2024-T3, T42 (Brackets)	7075-T73 (Pulleys/Tie Rod Fittings)
Elongation at Break	Elongation at Break
Room Temp: 12 to15 %	Room Temp: 7 to10 %
100°C (212°F): 16 to 19 %	100°C (212°F): 15 %
200°C (390°F): 22 to 26 %	204°C (400°F): 55 %
300°C (570°F): 70 %	316°C (600°F): 70 %
400°C (750°F): 114 %	371°C (700°F): 70 %
Maximum Temperature	Maximum Temperature
Onset of Melting (solidus): 502°C/935F or 935°F	Onset of Melting (solidus): 532°C, or 990°F

Table 6 Truss Materials #1

Control Cable Truss Assembly Material Properties - Heat	
1070 Carbon Steel cables	6061-T4,-T6
Elongation at Break	Elongation at Break
No Data Available	Room Temp: 22% (-T4), 12 % (-T6)
	100°C (212°F): 18 % (-T6)
	204°C (400°F): 28 % (-T6)
	316°C (600°F): 85 (-T6)%
371°C (700°F): 95 (-T6)%	
Maximum Temperature	Maximum Temperature
Onset of Melting (solidus): 1425°C	Onset of Melting (solidus): 615°C, or 1139°F

Table 7 Truss Materials #2

### 1.6.25 Flight Controls - GENERAL

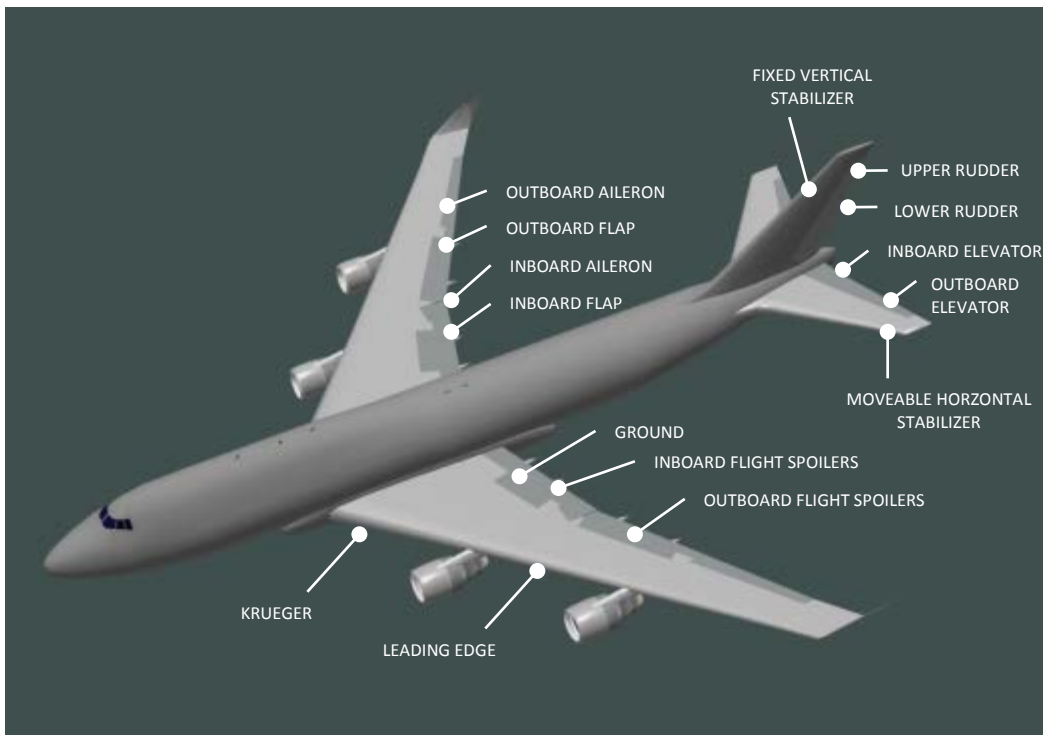

### 1.6.26 Flight Controls

The Boeing 747-400F has a conventional control architecture based on a cantilevered main planes supporting the high lift, spoilers and roll control surfaces, with the yaw and pitch control surfaces at the extremities of the aft fuselage at the empennage.

The primary flight controls consist of 10 movable surfaces for the three control axes:

1. Roll control - Inboard and outboard ailerons, two surfaces attached to each wing
2. Pitch control - Inboard and outboard elevators, two surfaces attached to each horizontal

stabiliser

3. Directional (Yaw) control - Upper and lower rudder, two surfaces attached to vertical stabiliser

The secondary flight controls consist of 46 movable surfaces for four functions:

1. Lift and drag device augmenting roll control - Flight and ground spoilers, six surfaces on each
2. Wing
3. High lift device for take-off, approach, and landing - Leading edge flaps, 14 surfaces on each wing; trailing edge flaps, two surfaces attached to each wing
4. Pitch trim device augmenting pitch control - horizontal stabiliser, one surface each side

All primary flight control surfaces are moved by hydraulic power control packages. Mechanical and hydraulic devices are used to provide normal control system feel.

- Conventional manual flight controls consist of control columns, control wheels, cables and quadrants and truss assemblies.

The actuators and power control packages responding to either manual or autopilot input signals.

Each primary flight control surface is moved by two or more power control packages. Each power control package is powered by only one hydraulic system; this provides each primary flight control surface with dual or triple path control. In the event of single hydraulic system or power control package failure, control of the aircraft is preserved.

- Autopilot power control packages and servos operate similarly except when electrically engaged, the input command is electrical rather than mechanical.

Position feedback signal from the power control packages and servos neutralizes the input command signal from the autopilot (flight control) computer when the control surface reaches new position.

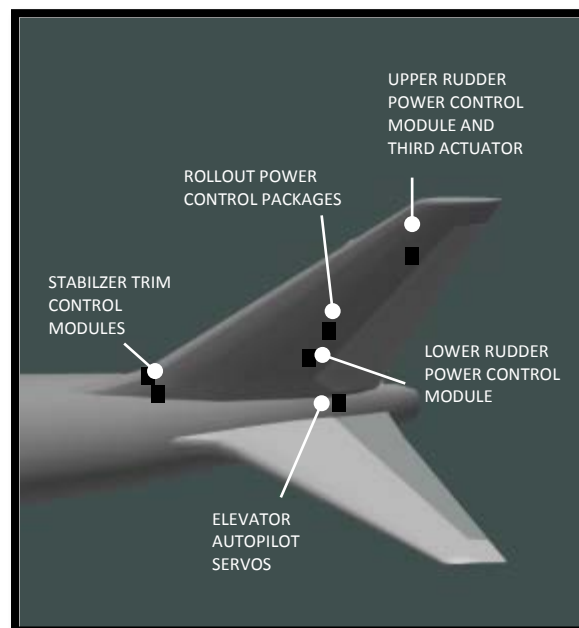

Figure 15 Power Control Modules/Servos/ Autopilot Control servos

## 1.6.27 Elevator Control System

### Pitch Control System

Four elevators located at the trailing edge of the horizontal stabilizer provide primary pitch control of the aircraft. The elevator control system provides the primary means to control the aircraft pitch.

The elevator control system is controlled from columns located in the cockpit. The control column has travel stops at 12.50 degrees nose down and 12.67 degrees nose up.

There are four elevators, two on each side of the trailing edge of the horizontal stabilizer. Control of the elevators is initiated through fore and aft motion of the captain's or first officer's control column.

The captain's and first officer's control columns are rigidly interconnected by a torque tube beneath the flight compartment floor, moving together in unison. There is transducer on the LH control column to record movement.

This input from the control columns is transmitted mechanically through control cables and linkages to a hydraulically powered elevator power control package (PCP) located forward of each inboard elevator.

Elevator feel at the control column is provided by a feel unit connected mechanically to the elevator aft quadrants. This feel force is related to aircraft speed and is controlled by Q pressure and stabilizer position.

Autopilot input to the elevator control system is received by the elevator autopilot servo control modules

The horizontal stabilizer is positioned to provide pitch trim. Stabilizer trim is set by a hydraulically powered drive mechanism.

Primary control of stabilizer trim is from switches on each aileron control wheel. The switches provide input to two stabilizer trim/rudder ratio modules (SRM) in the main electrical equipment center.

The separate cable loops travel aft through the floor beams of the upper deck to approximately station (STA) 680<sup>42</sup>, (WL) 305, at which point they are routed up to pulleys in the crown of the fuselage.

The left cable loop goes through two pulleys at STA 788, WL 349, LBL 18 on the left pulley bracket truss, The right cable loop goes through two pulleys at STA 775, WL 349, RBL 18 on the right pulley bracket truss. The cables continue back to the aft elevator quadrant in the tail of the aircraft.

The inboard elevator's normal travel range is 15 degrees down to 25 degrees up, and they are adjusted 1 degree up for neutral column position.

The outboard elevator travel is 18 degrees down to 22 degrees up, and they are adjusted 1 degree down for neutral column position.

The amount of force required to move the column is determined by the feel unit, which is connected to the aft torque tube. This unit also provides a centering force for the aft torque tube and column.

---

<sup>42</sup> The aircraft body is divided into reference planes, designated as stations (STA), waterlines (WL), and left or right buttock lines (LBL, RBL), measured in inches from fixed points of reference. The STA reference is a vertical plane perpendicular to the body centerline, located 90 inches forward of the aircraft nose. The WL reference is a horizontal plane located 91 inches below the lowest body surface. The RBL and LBL reference is a vertical plane on the body centerline.

### 1.6.28 Autopilot Control

There are three autopilot channels which can control the elevators. The autopilot actuators are connected to the aft torque tube. When an autopilot is engaged, an additional force of approximately 27 lbs at the control column is required to overcome the detent in the autopilot actuator.

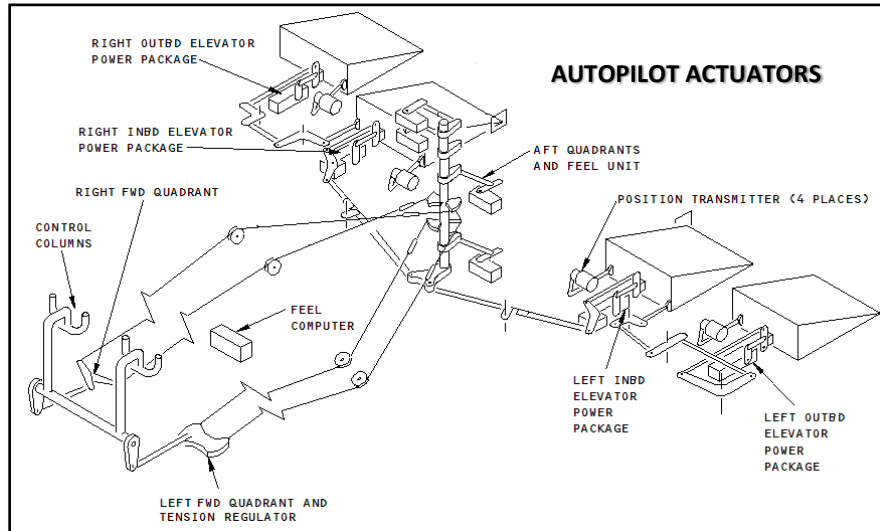

Figure 16 Auto Flight Elevator Controls

### 1.6.29 Rudder Control System

The rudder control system provides the primary means to control the aircraft yaw.

Control of the rudder is initiated through fore and aft motion of the captain's or first officer's pair of pedals, the pedals are rigidly interconnected by a pushrod beneath the flight compartment floor, so they move in unison. This motion is transmitted a cable loop. The cables travel aft through the floor beams of the upper deck to approximately station (STA) 680, (WL) 305, at which point they are routed up to pulleys in the crown of the fuselage. The cable loop goes through two pulleys at approximately STA 788, WL 349, LBL 2 on the left pulley bracket truss.

The cables travel aft from there to the tail of the aircraft and the aft quadrant. From there mechanical linkages transmit the motion to hydraulic actuators at the upper and lower rudder surfaces.

### 1.6.30 Speed Brake [Spoiler] Control System

The speed brake control system is used to raise the spoiler panels to increase drag and reduce lift in flight and during rollout.

There are twelve spoiler panels numbered 1 thru 12 from left to right.

The following description is only concerned with the operation of spoiler panels that operate in flight as speed brakes, which are spoiler panels 3 thru 10. In addition, spoiler panels 5 – 8 have different operational characteristics than spoilers 3, 4, 9, 10, and since the position of spoiler panels 5 – 8 are not recorded by the FDR, the following description will only apply to spoiler panels 3, 4, 9, and 10.

The speed brakes are actuated by a control lever on the left side of the pilot's center console. The lever is connected through linkage to the speed brake drum mechanism, which is a cable quadrant assembly and a no-back brake. The cable quadrant is attached to a cable loop. The cables travel aft through the floor beams of the upper deck to approximately station (STA) 680, (WL) 305, at which point they are

routed up to pulleys in the crown of the fuselage. The cable loop goes through two pulleys at approximately STA 784, WL 341, LBL 44 on the left pulley bracket truss.

#### 1.6.31 Landing Gear Control System

The landing gear control system is operated by moving the control handle assembly in the landing gear control handle module. The control handle module is located on the right side of the pilots' center instrument panel. A cable system transmits control handle movement to two selector valves located in the body gear wheel wells. When positioned by the control handle, the selector valves direct hydraulic pressure to the actuators for gear and door retraction and extension.

#### 1.6.32 Brake Control System Description

The DFDR data indicates throughout the event the brakes indicated they were on.

##### Brake Controls

- Pedal movement is transmitted to brake-pedal-bus-crank assemblies through a set of bell cranks and push rods.

One brake-pedal-bus-crank assembly is installed forward of the captain's pedals and one forward of the first officer's pedals.

The cable quadrants are attached to separate cable loops. The cables travel aft through the floor beams of the upper deck to approximately station (STA) 680, (WL) 305, at which point they are routed up to pulleys in the crown of the fuselage. The left cable loop goes through two pulleys at approximately STA 785, WL 344, LBL 30 on the left pulley bracket truss. The right cable loop goes through two pulleys at approximately STA 768, WL 340, RBL 46 on the right pulley bracket truss.

#### 1.6.33 Review of Control Performance

The flight controls performance is analysed in detail in Section 2. The following is a brief review of the elevator performance and demonstrated control desynchronisation.

##### Review of Elevator Controls Performance

The relationship between the control column position and elevator position is designed to be consistent throughout the flight envelope if the system is operating correctly.

The force required to move the column changes as a function of airspeed, horizontal stabilizer position and autopilot engagement status.

The relationship between column and elevator may change slightly due to increased feel forces and also when the column is moved rapidly.

The figure below shows the relationship between column and elevator as recorded by the flight data recorder during the controls check prior to the accident flight takeoff.

Positive values represent motion of the column aft from neutral and elevator motion trailing edge up.

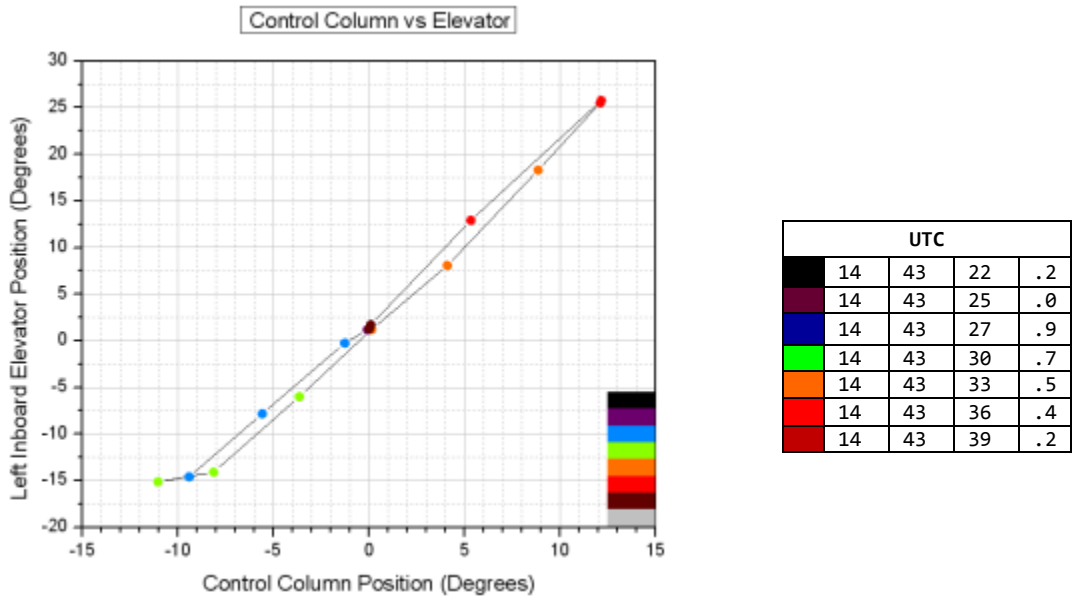

Figure 17 - Control column movement to elevator deflection

Control column movement to elevator deflection during the controls check prior to takeoff is normal as there is a linear correlation between the control column movement and the corresponding elevator trailing edge movement.

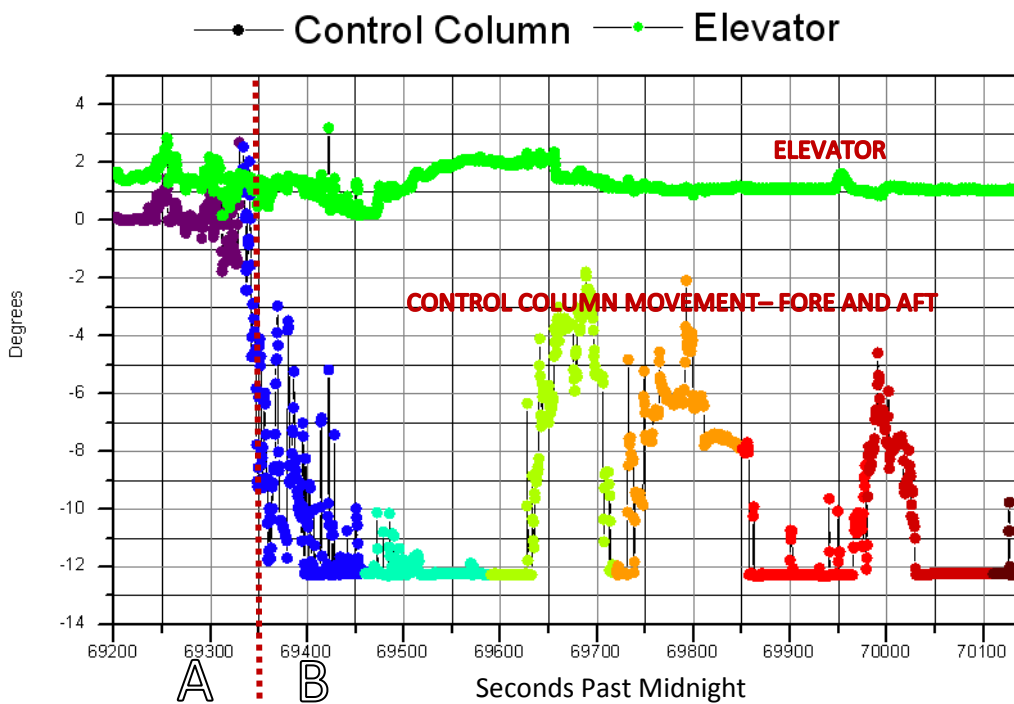

Figure 18 control synchronization/desynchronisation

### **A: Uniform Control Synchronization: Pre Main Deck Fire Warning**

### **B: Desynchronized Control Coordination: Post Main Deck Fire Warning**

The table above indicates the control column and elevator positions between 15:13:20 and 15:29:00 (69200 and 70140 in units of seconds past midnight<sup>43</sup>). The first fire alarm occurred approximately 25 seconds before the start of this timespan.

The control column versus elevator position for the same timespan with the same color mapping for elapsed time. For approximately the first 1.5 minutes the relationship between column and elevator travel is maintained, but for the remainder of the timespan the relationship is no longer present.

The autopilot was engaged until manually disengaged at 69240 (19:14:00), then engaged again for about 10 seconds at 69257 then engaged again at 69465 until the very end of the flight. When the autopilot was disengaged between 69267 and 69465, there was large motion of the column (all the way to the forward column stop) with very little corresponding elevator motion. After the autopilot was engaged there was both elevator motion (commanded by the autopilot) without column motion and column motion without elevator motion.

#### Control Column and Elevator Position

The control disparity is clearly identified between the control column displacement and the control surface movement. From the point at 69350 [red dotted vertical line], the synchronization of the control column movement and elevator position has deteriorated.

#### 1.6.34 Review of Rudder Control and Speed Brake Performance

To summarize the report findings for the rudder controls, shortly after the fire warning and continuing to the end of the flight there is large displacements of the rudder pedals with no corresponding motion of the rudder, this was noted to be consistent with loss of tension in the rudder control cables by the manufacturer..

For the Speed brake system, the report indicated that speed brake handle was moved to the in-flight detent position (full up position allowed in flight), but the spoilers moved only a few degrees instead of the expected 25 degrees or greater considering the flight conditions.

#### 1.6.35 Review of Landing Gear Performance

The FDR indicated that the landing gear handle was moved to the down position at approximately 19:38:00, however the other parameters indicated that the gear did not extend nor was the alternate extension used.

The Gear Pri All Down parameter did not change state, and the Gear disagree parameter went active, indicating the gear lever did not match the landing gear position for the remainder of the flight. The *Gear Lnd Config* was also observed to go active as the aircraft descended below 800 feet radio altitude, indicating the gear was not down.

---

<sup>43</sup> The Unix time reference used by the DFDR to indicate actual event time and elapsed time as a linear scale in time, defined as the number of seconds that have elapsed since midnight Coordinated Universal Time (UTC).



### 1.6.36 Review of Brake Performance

At approximately 19:15:30 the DFDR recorded that both the left and right brakes were applied and remained in that condition to the end of the flight. Review of the system design indicated that this could occur if both the left and right brake cables failed or went slack at the same time or if the wiring from the brake pedal applied switches shorted to ground within the same second.

### 1.6.37 Systems and Fire Protection Information

#### Pack Control

Pack control, fault detection, and overheat protection are all automatic. When an overheat or PTC fault is detected, the respective pack valve closes resulting in a pack shut down.

If a PTC does not switch automatically to the other PTC, selecting A or B manually selects the respective PTC when the Trim Air switch is ON. An attempt to restore pack operation may be made by pushing the pack reset switch.

If the pack cannot be reset, placing the respective Pack Control Selector to OFF extinguishes the Pack System Fault light for use by the operating packs.

#### Cargo Compartment Liners

Cargo compartment liners are a passive fire protection feature. The primary purpose of a cargo liner is to prevent a fire originating in a cargo compartment from spreading to other parts of the aircraft before it can be contained or extinguished.

On the main deck this liner is a fibre-reinforced plastic (FRP) which is a composite material made of a polymer matrix reinforced with fibres.

FRP can be severely degraded and/or damaged under thermal loading caused by fire affecting the structural integrity of the cargo compartment liner.

#### Cargo Compartment Liner Certification

The liner and floor materials in the cargo compartments comply with the test requirements specified in 14 Code of Federal Regulations and Issue Paper SE-1 "Protection of Critical Systems And Equipment Within Class E Cargo Compartments."<sup>44</sup>

The certification requirement for the liner fire resistance is an oil burner cargo liner test which requires a five minute flame exposure without exceeding 400<sup>0</sup>F/204°C, four inches [ten cm] above the top of the horizontal test piece. If the liner sample passes the five minute test, it should continue to keep temperatures below 400<sup>0</sup>F/204°C for the duration of an emergency.

Three specimens must be tested; there must be no flame penetration of any specimen within five minutes after application of the 1700°F. ± 100°F. (927°C. ± 38°C.) flame source.

This is a static test of the structure which is subjected to extreme heat but to no other input loads such as vibration, multi-axial loading, thermo mechanical loadings based on differential materials coefficients, acoustic or ballistic damage testing.

---

<sup>44</sup> The fire protection requirements can be found in Title 14 Code of Federal Regulations(CFR) 25.855, "Cargo or baggage compartments"; 14 CFR 25.857, "Cargo compartment classification"; and 14 CFR 25.858, "Cargo or baggage compartment smoke or fire detection systems."

For ceiling liners, the peak temperature measured at four inches above the upper surface of the horizontal test sample must not exceed 400° F (204°C). All other materials must be self-extinguishing.

The resulting degradation in the structural integrity of polymer matrix structures when subjected combined extreme heat and vibration is not a damage tolerance certification standard.

The material degradation represented by severe thermal loading can cause the instantaneous decrease in stiffness and strength properties of the cargo compartment liner material, in particular, the failure under combined thermal and mechanical loads when subjected to applied uniaxial stress and high heat flux/thermal loading.

Based on engineering judgement, after the exposure to the flame, the fiberglass becomes inert, it also has marginal residual mechanical strength remaining: the fibreglass is brittle and if subjected to vibration, movement or projectiles will fail under minimal load.

#### Main Deck Cargo Compartment Fire Protection Systems - Cargo Smoke Detection System

The main cargo smoke detection system is a draw-through air sampling system. A venturi ejector using bleed air creates a vacuum which pulls the sample air through the system. Multiple pick-up points are provided throughout the main deck cargo compartment.

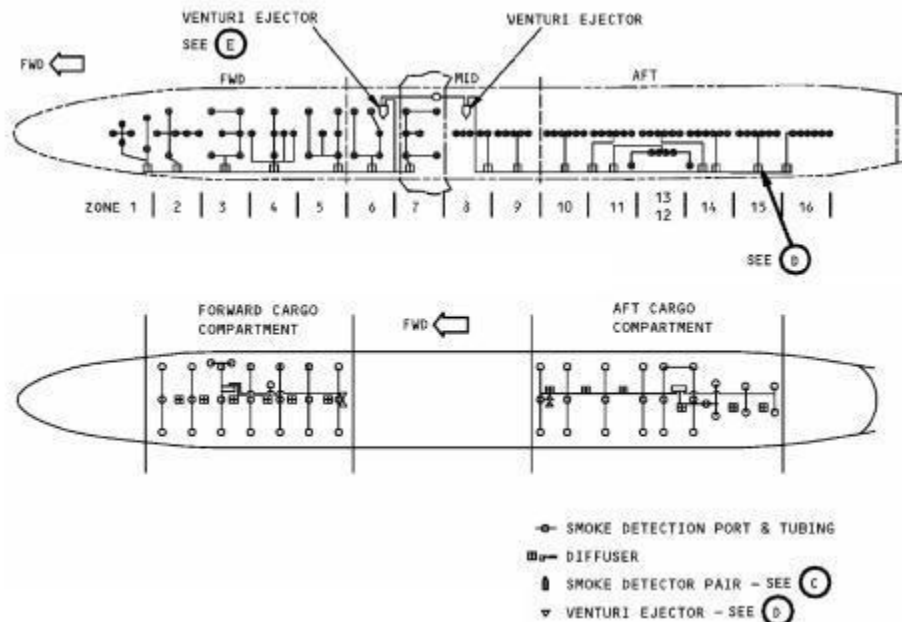

Figure 19 Class E Main Deck Cargo Compartment Smoke Detector Locations

The main cargo compartment is divided into sixteen smoke zones No. 1 - 16. Zones 1 through 7 are connected to the FWD venturi ejector and zones 8 through 16 are connected to the AFT venturi ejector. The smoke sampling ports in each smoke zone are connected to two detectors connected in dual loop/logic configuration. These dual detectors are installed in main deck cargo compartment.

There are six sampling ports located in smoke zones 1, 2, 3, 4, 5, 7, 11, 12, 13, 14, 15, and 16. There are five sampling ports located in smoke zones 6, 8, and 9.

Smoke zone 10 has six sampling ports if Satcom is installed. Zones 1 through to 8 have individual sampling ports to sample the air. Zones 10 and 13 through 16 have orifices located in piccolo tubes

attached to the interior of the ceiling panels. Zones 9, 11 and 12 use a combination of individual sampling ports and piccolo tubes for air sampling.

The smoke detection system monitors the main deck cargo compartment. There are a total of sixteen zones. Each zone has two smoke detectors for a total of thirty-two (on Freighters) smoke detectors on main deck cargo. The photocell in each smoke detector monitors the sample air for smoke. When the sample air containing smoke enters the smoke detector, light from a constant source is reflected onto the photocell causing an increase in output voltage and a signal is relayed to the flight deck.



Figure 20 Draw-through Smoke Detector

The forward lower cargo compartment has eight (on Freighters) smoke detectors, and aft compartment has four smoke detectors (eight on Freighters). Each smoke detector has a beacon lamp which supplies a smoke (fire) indication to flight crew when smoke is present in the air. The system can be tested by a test switch on the P5 pilot's overhead panel.

The smoke detection systems are designed to provide a visual indication to the flight crew in the early, smoldering, low-energy phase of a conventional fire prior to it breaking out into a high energy fire.

All aircraft are required to detect a fire within one minute. In all cases, the regulation requires that the smoke detection systems detect a fire at a temperature significantly below that at which the structural integrity of the aircraft could be adversely affected, although how this is achieved through the detection of smoke only is not adequately defined in the regulation.

Draw-through (also called active) smoke detectors continuously monitor a sample of air drawn from the cargo compartment for the presence of smoke which can be an indication of a fire condition.

A draw-through detection system consists of a distributed network of sampling tubes that bring air sampled through various ports in the cargo compartment.

The smoke detection systems give the flight crew visual and/or aural indications of abnormal conditions in the main deck compartment and lower cargo compartments.

The generated signal will create master fire warning light, fire bell, warning, and advisory EICAS (engine indicating and crew alerting system) messages. The fire warning bell sound comes from 2 multi-purpose speakers in flight deck. The master fire warning light indicators are located above captain and first officer's main instrument panels.

Essential flight controls, engine mounts, and other flight structures located in designated fire zones or in adjacent areas which would be subjected to the effects of fire in the fire zone must be constructed of fireproof material or shielded so that they are capable of withstanding the effects of fire.

### Main Deck Ceiling Panels

The main deck ceiling panels contains these type of panels:

- The forward ceiling panels which are in the forward area. The panels contain lights, and access panels to get access to the wire bundles.
- The transition ceiling panels which are aft of the forward ceiling panels.
- The decompression vent ceiling panels which are aft of the transition ceiling panels. The panels contain lights, access panels, and decompression vent assemblies.
- The duct shroud ceiling panels which are on the left and right sides and aft of the decompression ceiling panels.
- The smoke detection ceiling panels which are in between the duct shroud ceiling panels. The panels contain the smoke detection tubes along the center of the panels, lights, and access panels to get access to the control cables.

The linings in the proximity to the location of the fire in zone3 are shown below in green.

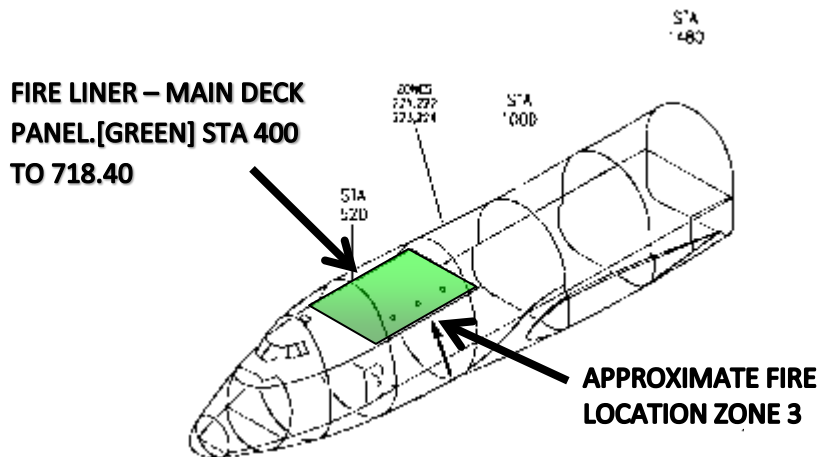

Figure 21 Deck Ceiling Transition Panels STN 400 TO 718.40



Picture 1 Cargo Compartment Liner Transition Panels At The Fire Location

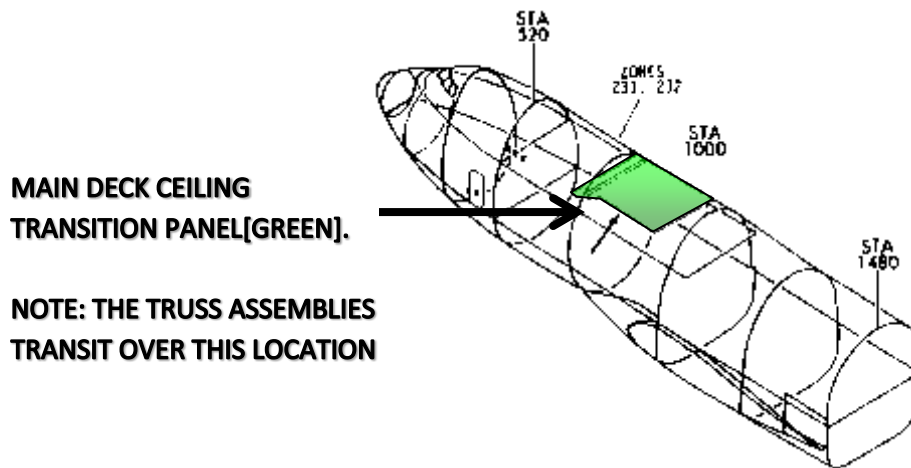

Figure 22 Main Deck Ceiling Transition Panels STN 718.74 TO 900

#### 1.6.38 Auto Flight - Automatic Flight - Approach and Landing

The Auto Flight Director System [AFDS] provides guidance for single or multiple autopilot ILS approaches.

Pushing the APP switch arms the localizer in roll mode and glideslope in pitch mode.

- › Either localizer or glideslope can be captured first.
- › Pushing the LOC switch arms only the localizer.
- › Localizer capture can occur when the intercept angle is less than 120 degrees.

Runway Alignment and Asymmetric Thrust Compensation:

AFDS controls the rudder during multiple A/P approaches to compensate for crosswind landings and engine-out asymmetric thrust conditions.

Flare: The flare manoeuvre brings the aircraft to a smooth automatic landing touchdown.

The flare mode is not intended for single autopilot or flight director only operation.

Flare arms when LAND 3 or LAND 2 annunciates. At approximately 50 feet radio altitude, the autopilots start the flare manoeuvre. FLARE replaces the G/S pitch flight mode annunciation.

During flare:

- › at 25 feet radio altitude, the auto throttle retards thrust levers to idle
- › IDLE replaces the SPD auto throttle flight mode annunciation
- › at touchdown, the FLARE annunciation no longer displays, and the nose lowers to the runway

Note: The rollout phase is not considered for this accident as the landing gear disagree caution was active and the landing gear remained up.

#### 1.6.39 Auto Throttle

The 747-400 Auto throttle limits the maximum commanded speed to the maximum operating speed (V<sub>cmax</sub>) calculated by the FMC.

The FMC uses the VMAX CONF signal from the Modularized Avionics and Warning Electronics Assembly [MAWEA] for the V<sub>cmax</sub> when flaps are extended. The MAWEA uses flap position in its calculation. It does not use flap handle position.

The Auto throttle has three functioning modes: Speed, Thrust and Flight level Change.

In speed mode the auto throttle will limit the target speed to be less than or equal to V<sub>cmax</sub>.

In thrust mode the auto throttle will set the speed target to V<sub>cmax</sub> and let the thrust limiting function limit thrust to the thrust reference value.

In Flight Level Change [FLCH] mode the autopilot/flight director provides speed control and the auto throttle would not respond to over or under speed conditions.

## 1.7 Meteorological Information

---

### 1.7.1 Dubai [OMBD/DXB] Weather

The accident occurred at approximately 15:41 UTC/19:41 Gulf Standard Time.

Weather observations reported for Dubai International Airport at the time of the accident at 1600Z the surface observation reported the following:

METAR OMDB 031600Z 24004KT 8000 NSC 36/27 Q1000 NOSIG

Description: Winds from 240 degrees at 4 knots, temperature 36 °C and dew point 26°C, and no significant clouds or weather.

The Terminal Area Forecast [TAF<sup>45</sup>] at the time of the accident was similar, with a minor wind change which is not considered significant.

Additional meteorological observations:

---

<sup>45</sup> METAR is the international standard code format for hourly surface weather observations which is analogous to the SA coding currently used in the US. The acronym roughly translates from French as *Aviation Routine Weather Report*. SPECI is merely the code name given to METAR formatted products which are issued on a special non-routine basis as dictated by changing meteorological conditions. The SPECI acronym roughly translates as *Aviation Selected Special Weather Report*. TAF is the international standard code format for terminal forecasts issued for airports. The acronym translates to *Terminal Aerodrome Forecast*, and is analogous to the terminal forecast (FT) coding format currently used in the US.

SUNSET: 18:36 LOCAL/ 279°← [direction of sunset]

CIVIL EVENING TWILIGHT<sup>46</sup> (CET): 18:59 GST

The aircraft was airborne at dusk (at DXB's airport elevation), climbed west towards the sun which was on a radial of 279° to the flight, this would have provided sufficient ambient solar illumination as the aircraft was climbing to FL320 to illuminate the flightdeck as the Sun descended and the flight climbed towards the West.

When the aircraft turned back onto 106° and subsequently 095° and descending, the cockpit was in shadow as the aircraft travelled East.

---

<sup>46</sup> Civil Twilight: the time at which the sun is 6 degrees below the horizon. At this time, there is enough light for objects to be clearly distinguishable and that outdoor activities can commence (dawn) or end (dusk) without artificial illumination

1.7.2 Sunrise Sunset Table for OMAL/DXB September 03, 2010.

One factor concerning the ambient lighting and the reduction of the visibility in the cockpit is the available light in the cockpit.

The flight was airborne shortly before dusk, the airport elevation is at sea level. The ambient light would have remained available to the crew as the climbed in altitude and travelled west. However, as a cockpit visibility factor, the return to the east and the subsequent descent reduced the available ambient light and the cockpit lighting has minimal advantages to the crew in a completely smoke filled environment.

---

Sunrise/Sunset		
Dubai International Airport (DXB)		
Dubai, United Arab Emirates		
N25° 15' 00" E055° 19' 48"		
Fri, Sep 03 2010 Time zone		
Gulf Standard Time: GMT+ 4		UTC
Local time [above TZ]	11:31:00	7:31
Midday at	12:17:00	8:17
Length of day	12:36:00	8:36
Astro Twilight Start	04:42:00	0:42
Nautical Twilight Start	05:09:00	1:09
Civil Twilight Start	05:37:00	1:37
Sunrise	06:00:00	2:00
Sunset	18:36:00	12:36
Civil Twilight End	18:59:00	12:59
Nautical Twilight End	19:27:00	15:27
Astro Twilight End	19:54:00	15:54

---

Table 8 Sunrise/Sunset DXB SEPT 03 2010



## 1.8 Aids to Navigation

All navigation aids at the destination aerodrome – OMBD/DXB – were serviceable and functioning.

The Air Traffic Engineering Services ATES Daily Occurrence Log indicates that ILS was operational. This concurs with the operation detailed in the ATC Tower Log and the DFDR data concerning the partial ILS capture.

### 1.8.1 OMBD/DXB - Instrument Approach Chart for Runway 12L



Figure 23 Instrument Approach Chart - Dubai [OMBD/DXB] RWY12 Left

## 1.9 Communications

The communication problems experienced by the crew of the accident flight, the communication processes established to communicate between the accident flight, relay aircraft and the fixed ground stations are analysed in detail in Section 2.

This section will detail the factual information relating to the various aspects of the communications in place at the time of the accident: the accident aircraft, the relay aircraft, the Air Traffic Control Units [ATCU] and the landline communication used for the ATCO's to communicate during the accident flight.

### 1.9.1 Background Information – ATC Communication

The accident flight departed the UAE through the UAE FIR, crossing into the Bahrain FIR area enroute to Europe. The course to return back to Dubai returned back through the UAE FIR.

For reasons that will be detailed in Section 2, the crew could not talk directly to the UAE Area Controllers or the approach or terminal controllers at DXB.

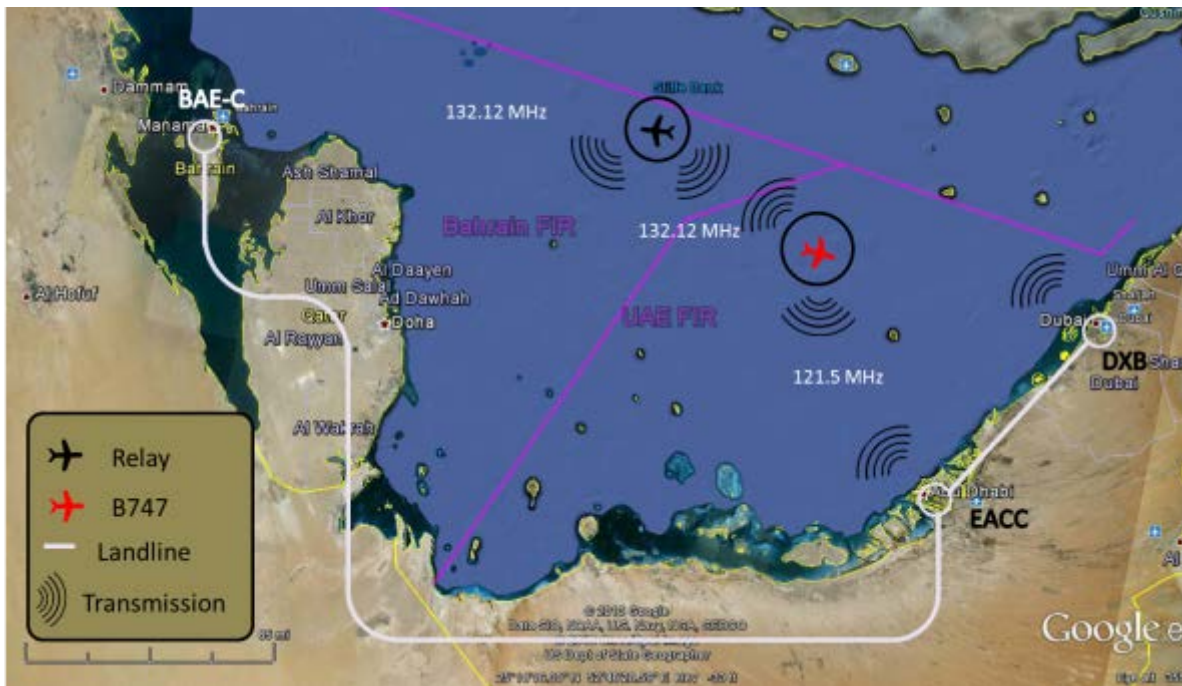

Figure 24 Relay Communication Schematic

During the emergency descent from the Bahrain FIR into the Emirates FIR, communication between the ATC at Bahrain, the UAE and the accident aircraft were complex due to the flight crew's inability to change the radio frequency due to the smoke in the cockpit.

As the crew could not change radio frequencies from the BAH-C frequency, BAH-C used relay aircraft to communicate with the accident aircraft as the aircraft was transitioning back to DXB, through the Emirates FIR. BAH-C and Emirates Area Control Center [EACC] were in landline communication.

Outbound from DXB, the crew passed from the Emirates FIR into the Bahrain FIR. Standard practice is to set the radio frequency for the next ATC region or FIR. BAH-C had confirmed the aircraft for the next destination waypoint of COPPI and advised that the aircraft was on radar. The flight crew acknowledged the ATC transmission from BAH ATC on the BAH-C frequency.

When the aircraft turned back to DXB, the flight crew of the aircraft advised BAH-C that they would stay on the BAH-C frequency due to smoke in the cockpit as it was not possible to change radio frequencies from BAH-C to the UAE ATC frequencies required for the return back through the UAE FIR and to DXB.

BAH-C contacted transiting traffic within effective VHF range of the aircraft and Bahrain ATC. The transiting traffic aircraft relayed messages to BAH-C from the crew. BAH-C were in landline communication with the controllers in the UAE.

The process was reversed to communicate the required heading, altitude, speed and tracking data back to the flight crew of the aircraft.

### 1.9.2 ATC VHF Radio Transceivers

ATC VHF radio transceivers normally cover 360° in Azimuth although VHF radio is subject to line-of-sight restrictions, and the range varies proportionally to the altitude of the receiving equipment.

As the aircraft descended and moved farther away from the BAH-C transceiver site, it exited the usable range for direct two-way communication with BAH-C.

Following the emergency descent to 10,000 feet, all communication with BAH-C was through relay aircraft. Nominal effective range of communication is shown below.

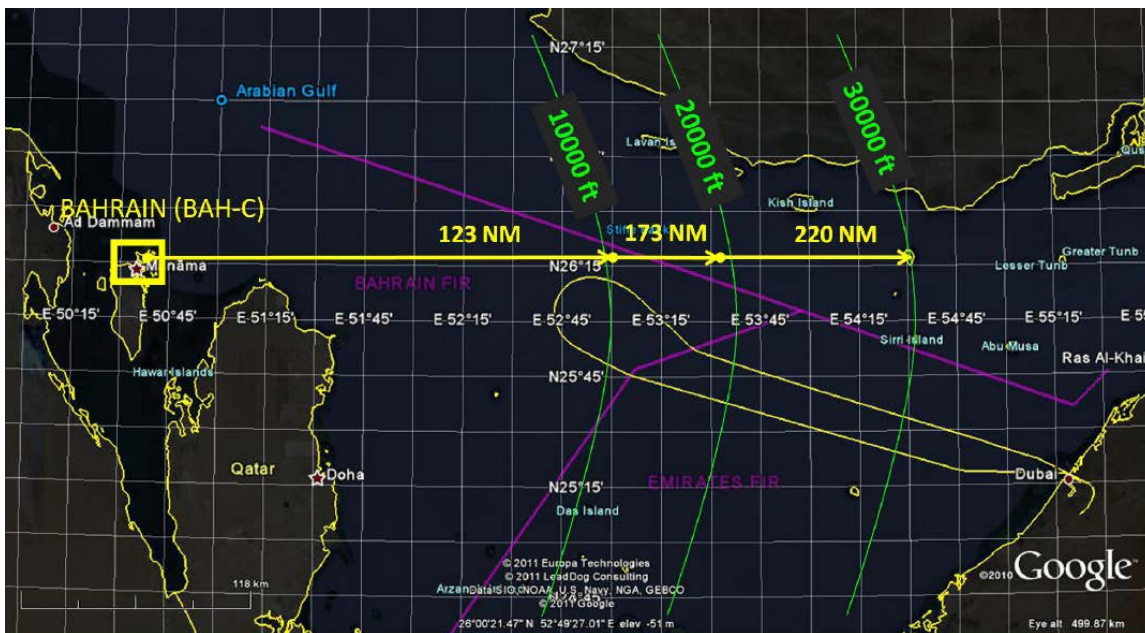

Figure 25 - VHF Communications Range from BAH-C into the UAE FIR

### 1.9.3 Air Traffic Control

#### Emirates Area Control Center [EACC]

Responsible for the provision of en-route services, alerting service and flow control within the Emirates Flight Information Region (FIR). The EACC is stationed in Sheikh Zayed Air Navigation Centre (SZC), Abu Dhabi.

The EACC coordinates all traffic flow into in the UAE FIR, which included the coordination with DXB for this emergency.

The interception of aircraft rules in the UAE FIR apply to civil aircraft that are non-responsive only.

All coordination between ATCU's, either in the UAE or in adjacent FIR's is through landline only. There is no mobile phone option available to the controllers.

All Communication between DXB positions and EACC are via landline, programmed into Garex Voice Communication Control Systems [VCCS].

#### 1.9.4 Bahrain Area East Control [BAE-C]

As the accident flight was tuned to the BAE-C frequency of 132.12 MHz, the crew could not change to the ACC frequency [132.15 MHz], BAE-C coordinated all communication with the accident flight and ACC in Abu Dhabi.

Due to lack of radar data sharing between the UAE and Bahrain, BAE-C did not have radar coverage over the UAE airspace, subsequently the Bahrain ATCO handling the emergency could not see the Secondary Surveillance Radar [SSR] information for the accident flight.<sup>47</sup>

Had the SSR data been available, providing the heading, speed and altitude information process would have been simplified. However, the primary problem was the radio frequency selection problem experienced by the PF, not the tracking data availability of the BAE-C controller.

#### 1.9.5 Dubai Air Traffic Control Unit

Dubai ATC declared a full emergency when they received the information, via landline, that the flight was returning with a fire warning and unable to maintain altitude. The flight crew did not select transponder code 7700, which indicates an emergency situation.

The exact nature of the emergency, and level of difficulty experienced by the crew was not communicated to the ATCO's in DXB. The advisory received was a fire warning and radio problems, DXB were anticipating that if/when the aircraft could select a frequency of 118.75 MHz, then the flight communication had been relayed.

Dubai ATC did not attempt to contact the flight on frequency 121.5MHz as the coordination is managed by EACC.

The ATCU is equipped for surveillance radar approach [SRA] talk-down procedures and also for non-compass/no-gyro SRAs if required.

#### 1.9.6 Relay Aircraft Communications

As the BAE-C controller has SSR data on traffic on the BAE-C radar, approaching, or transiting the Bahrain FIR, the majority of the aircraft utilised as relays between Bahrain ATC and accident flight were in or approaching the Bahrain airspace. When the accident flight was within reasonable proximity to DXB at around 20-30 DME from Dubai, the VHF direct line of communication was at the limit of the relays to maintain clear communications due to their relays height and range.

Note: The possibility of utilising aircraft still within the DXB CTA, to select Bahrain's frequency on the no.2 radio and relay info directly from the DXB ATCO's was not considered at the time of the emergency.

---

<sup>47</sup> Secondary surveillance radar (SSR) is a radar system used in air traffic control (ATC), that not only detects and measures the position of aircraft i.e. range and bearing, but also requests additional information from the aircraft itself such as its identity and altitude range and bearing  
This is analysed further in Section 2

### 1.9.7 AIP Published Emergency Frequencies - 121.50 MHz/243 MHz

The UAE Aeronautical Information Publication [AIP] valid at the time of the accident published two emergency communication frequencies

1. 121.5 MHz - Civil guard frequency
2. 243 MHz - Military Air Distress (MAD) or UHF Guard

Both options are available in the UAE FIR for emergency traffic

### 1.9.8 Air Traffic Control In The Gulf Region

The Designated Area of Coverage (DOC) for the FIR

The Designated Area of Coverage (DOC) for the FIR regions are in accordance with industry normative range and coverage requirements for VHF coverage.<sup>48</sup>

During the emergency descent from the Bahrain FIR into the Emirates FIR, communication between the ATC at Bahrain and the UAE and the accident aircraft was complex due to the crew's inability to change the radio frequency due to the smoke in the cockpit area.

As the crew could not change radio frequencies from the BAE-C frequency, BAE-C utilized relay aircraft to communicate with the accident aircraft as it was transitioning back to DXB, through the Emirates FIR. BAE-C and EACC which were in landline communication, ACC was in landline communication with DXB. As EACC is the regional coordination center, DXB was unable to talk direct to BAE-C, so all communication is linked through EACC.

ATC VHF radio transceivers normally cover 360° in Azimuth although VHF radio is subject to line-of-sight restrictions, and the range varies proportionally to the altitude of the receiving equipment.

As the aircraft descended and moved farther away from the BAE-C transceiver site, it exited the usable range for direct two-way communication with BAE-C.

Following the emergency descent to 10,000 ft, all communication with BAE-C was through relay aircraft. Nominal effective range for VHF communication was line of sight.

### 1.9.9 Transmission on the 121.5 MHz Aircraft Emergency Frequency

The aircraft emergency frequency (also known as the guard frequency) is a frequency used on the aircraft radio band reserved for emergency communications for aircraft in distress. The frequencies are 121.5 MHz for civilian, also known as International Air Distress (IAD) or VHF Guard frequency, an open channel which aircraft have tuned as a listening watch audio channel.

---

<sup>48</sup> Refer to ICAO Annex 10.

**AUDIO TAPE TRANSCRIPT**

Centre : Emirate: **ACC VHF Distress**  
 AOR Reference : AOR-ROSI-0661-100903-ATC  
 (AOR-ROSI-0661-100903-ATC-VHF DISTRESS TT)

Time HHMMSS (UTC)	Qom (m)	Agency	Text
15:21:57	121.5	ACCC	UPS SIX this is UAE on one two one five ah do you copy
15:22:09	121.5	ACCC	UPS SIX UPS SIX, this is UAE centre on one two one five copy
15:22:22	121.5	ACCC	UPS SIX UPS SIX, this is UAE , when able contact UAE centre one three two decimal on five, one three two one five when able
15:22:35	121.5	ABY108	Centre from Arabia one zero eight on guard, they're talking to ah Bahrain on one three two one two, and ah they cannot switch to you because they cannot see their radios
15:22:47	121.5	ACCC	Ok copied that thanks
15:22:27	121.5	UNKNOWN ACFT(1)	UPS on MAYDAY your altitude is fifteen thousand feet, one five zero. You can descend to nine thousand feet nine thousand
15:23:42	121.5	ACCC	UPS SIX this is UAE on guard, ah you're cleared direct to Dubai, copy descending Niner thousand feet , and Dubai tower frequency one one eight decimal seven five
15:15:08	121.5	SVA571	UPS SIX if you can hear me Saudia five seven one, you can call Dubai tower on one one eight seven five
15:27:51	121.5	ACCC	Station calling on guard say again
15:32:30	121.5	FDB159	And for Sky Dubai two zero one we need relay help on one three two one two with UPS
15:33:04	121.5	ACCC	Sky Dubai on five nine thanks for your help there, I think the UPS SIX is now talking to Dubai frequency, and ah he's three zero miles from the field
15:35:12	121.5	UPS6	MAYDAY MAYDAY UPS SIX anybody hear me
15:35:17	121.5	UPS6	UPS SIX can you hear me
15:35:20	121.5	UNKNOWN ACFT(2)	UPS SIX are you on guard
15:35:26	121.5	UNKNOWN ACFT(2)	UPS SIX go ahead
15:35:38	121.5	UNKNOWN ACFT(2)	UPS SIX go ahead
15:35:43	121.5	UNKNOWN ACFT(3)	Traffic on guard repeat your message repeat your message
15:37:04	121.5	UNKNOWN ACFT(4)	UPS SIX say your message again
15:37:26	121.5	UPS6	MAYDAY MAYDAY

Figure 26 Transcript ATC Audio of 121.5 MHz Emergency Communications Exchanges

### 1.9.10 Aircraft Health Management and Aircraft Communications Addressing and Reporting System (AHM & ACARS)

The Aircraft Communications Addressing and Reporting System (ACARS) is a digital data-link system that provides data communication between an aircraft and the airline's ground-based computers. Networks of ground communication stations provide radio coverage. With the installation of the Satellite Communication (SATCOM) system, worldwide coverage is possible.

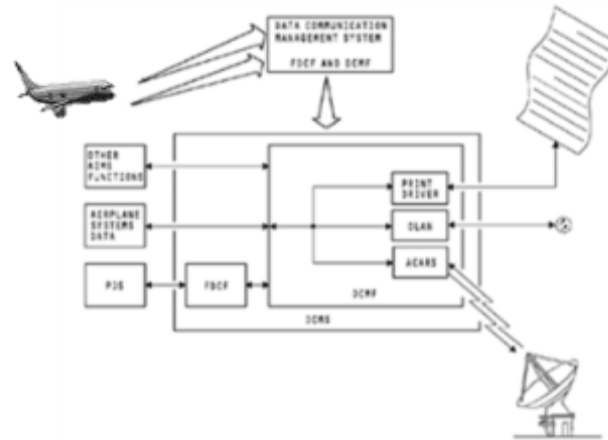

Figure 27 Typical ACARS System – Aircraft to Ground Station

The AHM data consists of various ACARS messages received from the aircraft. Summary of Aircraft Information Available Via ACARS:

1. RTE reports – Real Time Events. When the Central Maintenance Computer (CMC) receives a faults message from an aircraft system and is able to correlate it to a Flight Deck Effect (FDE) such as an EICAS message an RTE report is initiated by the CMC and sent over ACARS.

Each entry described below may include both a fault message and the correlated flight deck effect.

2. On-Condition Reports. The ACARS system is programmed to send reports when certain events occur. These events were defined by operator and include APU Shutdown report, Takeoff Report, and periodic Position Reports.

3. EICAS Synoptic Snapshot displays. On this flight ECS page synoptics were sent from the aircraft in response to request from the ground-based AHM system.

The ACARS interfaces with the VHF communications system to transmit and receive data.

The primary component of the ACARS is the Communications Management Unit (CMU). The CMU interfaces with many other systems to collect and distribute data.

Within the context of this investigation, the ACARS data was instrumental in determining the fire location via the fault messages. As the fire affected the various sensors, wire loops, antennae and triggered the fire warnings, each message was transmitted via ACARS to the operators Aircraft Health Monitoring [AHM] system. This data is transmitted in real time, the data can then be decoded and analysed.

### 1.9.11 Aircraft Health Monitoring

AHM gathers and processes aircraft fault indications down-linked from the aircraft's onboard central maintenance computer (CMC). The CMC provides information that can be used to determine whether there are conditions that could affect dispatch on the following flight and provides an entry point into the Fault Isolation Manual (FIM) for speedier fault isolation. AHM consolidates, filters, and prioritizes CMC information for optimal decision support and use in maintenance planning.

### 1.9.12 The Boeing 744AF Air Traffic Control Radar Beacon System, (ATC system)

The Air Traffic Control Radar Beacon System, (ATC system), supplies aircraft track, altitude and identification data to an ATC ground station. The ATC transponder responds to an interrogation from an ATC ground station. The ATC system responds to ground station interrogations in one of three different modes: Mode-A, Mode-C and Mode-S. Mode-A and Mode-C provide identification and altitude information. Mode-S provides selective aircraft identification and data link capabilities. After a ground station interrogation, the transponder automatically transmits a pulse coded reply signal in one of the above modes. The mode of reply is determined by the mode of interrogation.

The transponder transmits a squitter signal, alternating between the top and bottom antennas, approximately every second. The squitter signal is coded with the aircraft's mode S address.

### 1.9.13 Boeing 747-400F Radio/Communications

As outlined above, radio communication is a significant factor in this investigation. The inability of the crew to change selected frequencies is a contributing factor to the accident.

This variant of the Boeing 747-44AF involved in this accident has a modern standard radio equipment and communications ability. The following is a description of the radio set up available to the crew of the accident aircraft. It is a typical radio set up for this type of aircraft.

#### 1.9.14 Operators Standard Operating Procedures (SOP) for Radio Panel Setup and Communications

##### Radio/Audio Panel Setup

The following information was based upon input from B747-400 Check Airmen, guidelines defined in the IOE Instructor's Guide, and the Aircraft Operating Manual (AOM).

According to the AOM, below are the checklist items for preflighting the Captain's, Center and First Officer's audio control panels:

LEFT RADIO TUNING PANEL . . . . . SET

Verify OFF light extinguished.

Verify Offside Tuning light extinguished.

Check HF radios in accordance with AOM, Chapter 4 procedures. Do not operate HF radios during or near fuelling operations.

CENTER RADIO TUNING PANEL . . . . . SET

Verify OFF light extinguished.

Verify VHF C selected and DATA displayed in ACTIVE frequency display.

RIGHT RADIO TUNING PANEL . . . . . SET



Verify OFF light extinguished.

Verify Offside Tuning light extinguished.

Radio Tuning Panel – Center Pedestal



Picture 2 - Radio Tuning Panel and Audio Control Panel

### Standard Operation

In normal B747-400 UPS operations, the flight crew would use the VHF L for all ATC (air traffic control) communications, the VHF R set with 121.50 as the active frequency and the standby frequency on VHF R tuned to a future frequency as a reminder (for instance, after receipt of the ATC pre-departure clearance in which a ATC departure frequency was given, the pilots would tune that frequency in on the standby). VHF C would always be used for ACARS data communications.

The Captain's radio tuning panel would have VHF L selected (with the green light illuminated) with the ATC frequencies tuned, and the MIC selected to VHF L to transmit to ATC. The First Officer would have had VHF R (with the green light illuminated) with 121.50 dialled in the active window. Additionally, he would have had the MIC selected to VHF L so as to monitor ATC communications from his audio control panel.

Typically for these B747-44AF operations, the VHF C is used for ACARS and would display DATA on the center radio tuning panel.

The SATCOM system could be used to dial any conventional phone number; however, UPS policy is that SATCOM may never be used for personal phone calls due to its high cost. SATCOM is not normally used for ATC voice communications. However, the flight crew could establish voice contact with ATC facilities using SATCOM if necessary. An ATC facility directory with phone numbers is included in the SATCOM CDU pages. SATCOM could also be used to contact Flight Control, Maintenance Control or other company facilities if necessary.

## Monitored Audio Sources

The pushed round green volume knobs on the ACP are used to select the corresponding source to be monitored, and the volume for that source. These knobs are pushed in to monitor, (pushed again to deselect), and rotated for volume control. Any or all of these sources can be selected by the pilot, and if any source is selected, it is recorded on that crewmember's CVR channel, along with his/her hot microphone.

## Relative Volume of Each Source

The volume of each source as recorded on the crewmember's CVR channel should be relative to the volume setting on the ACP. i.e. if the pilot were monitoring VHF-L (left) and VHF-R (right), with the volume of VHF-L set louder than VHF-R, the CVR recording should result in the VHF-L audio being louder than VHF-R.

## Transmitting

Only one radio source can be selected for transmitting at any given time. Selecting a source with the corresponding "MIC CALL" button will deactivate any other previously selected source. The MIC CALL buttons select the "active" source to transmit on, but do not actually "key up" the transmitter for communications. One of the transmit switches (one is located on the control yoke, the other on the ACP) must be pressed to key up the transmitter. The MIC CALL button will also automatically select its corresponding source for monitoring, even if that source's volume knob is not pressed in.

## Recording of Pilot's Voice on CVR - When Transmitting on Radio

When making a radio transmission, the sound of the pilot's voice is recorded by the CVR though a 'sidetone' which is generated by the radio. As noted above, when not transmitting on a radio, the pilot's voice is captured by his boom (or mask) microphones that are always on or "hot", and that signal is sent directly to the CVR. When making a radio transmission, the signal from the pilot's microphone is first routed to the selected radio, and then to the CVR via the sidetone generated by the radio. This is the same signal that's routed to the pilot's headset, so that he/she can hear their own voice when transmitting. This sidetone is affected by the volume setting on the ACP for the radio in use. As a result, if the volume knob is set all the way down, the pilot will not hear his/her own voice in the headset when making a radio transmission. The CVR recording will also reflect that volume setting and the pilot's voice will not be heard on the respective CVR channel (or it will be heard at a low, nearly inaudible volume).

## Emergency Frequency 121.5 MHz

There is a unique feature of the radio system which causes any of the VHF radios to be automatically selected for monitoring, if the emergency frequency of 121.5 is tuned in and set as active on any radio. This will occur regardless of the ACP settings configured manually by the pilot. This feature does not automatically select the MIC CALL button for the radio. Anecdotal evidence from B747 pilots suggests that this feature may also automatically adjust the volume of the affected radio to some non-zero value. Boeing was unable to find any documentation related to an automatic volume adjustment of radios tuned to 121.5, and was unable to duplicate those symptoms during an informal test in their audio lab.

## Radio Communication System

The radio communication system has multiple avenues to facilitate aircraft to ground communications. The primary source to the pilot for ground voice communications is through any one of three VHF (very high frequency) radios installed on the aircraft. Alternate voice communication sources are any one of two HF (high frequency) radios, Selective Calling (SELCAL) and Satellite Communications (SATCOM).

There is also a means to transmit data (non-voice) between the aircraft and ground facilities. The primary source of data transmission is through the Aircraft Communication Addressing and Reporting System (ACARS).

Another unique feature of data transmission available is an Aircraft Health Management (AHM) system that would collect performance, fault and alert information on board the aircraft in real time and relay that information to the UPS ground operations via the ACARS system.

### VHF Radio Communications

There are three VHF radios designated as VHF L(ef), C(enter), R(ight) and two HF radios designated as HF L(ef), R(ight). Any VHF or HF radio can be controlled by any of the three radio tuning panels. The audio control panels control voice transmission and receiver monitoring. VHF L, VHF C, or VHF R can be configured for voice or ACARS data communication. VHF radios are equipped with 8.33 kHz channel spacing. Pilot control of the 3 VHF radios and 2 HF radios was enabled through the radio tuning panels and the audio control panels.

Each pilot (Captain and First Officer) has their own radio tuning panel and audio control panel, and both are located on the aft aisle stand in the cockpit between the pilots on the center pedestal. In addition, each observer's station has its own audio control panel located near the observer's oxygen mask box.

### Radio Tuning Panel

The three radio tuning panels are used to tune the VHF and HF radio frequencies. The panels are designated left (Captain's), center (typically used for ACARS data), and right (First Officer's), and are normally configured to control the respective VHF and HF radios (left tuning panel controls left VHF radio, etc.). If a radio tuning panel fails, it can be disconnected from the communication radios using the off switch. An offside tuning indicator light (located between the active and standby frequency windows) on each radio tuning panel indicates one of the following conditions when illuminated:

The radio tuning panel is configured to control a radio that was normally controlled by another radio tuning panel (e.g. if the left tuning panel were configured to control the right VHF radio)

A communication radio not normally associated with that radio tuning panel is selected and the radio can also be tuned by another radio tuning panel. (e.g. if more than one tuning panel is configured to control the same radio, the offside tuning indicator will illuminate on all the affected tuning panels)

Frequencies are tuned with a rotary knob and displayed in the right side "Standby" window. When the pilot wishes to make that frequency usable, the center button is pushed to make that frequency "active" and available to transmit and receive on. When ACARS is selected in the CDU for data transmission over the VHF radio, that particular radio tuning panel will show "DATA" in the active window.

NOTE: If the center radio is configured with DATA in the active window, and the button is selected to transfer out of DATA mode, the DATA LINK would be lost (if neither SATCOM nor HF are available).

When one of the two HF frequencies is selected, the HF SENS knob is available to adjust the sensitivity of the respective HF receiver. The AM switch will set amplitude modulation of USB (upper side band) mode for the selected HF radio.

### Audio Control Panel [ACP]

The audio control panels are used to control radio and interphone communication systems. Navigation receiver audio can also be monitored. The captain, first officer, and first observer audio control panels are installed on the aft aisle stand. The second observer audio control panel is installed on the sidewall

panel. Microphones are keyed by pushing the desired audio control panel transmitter select switch (MIC CALL) and then selecting one of the following:

- The MIC position of a control wheel switch (the bottom rocker position on the yolk switch)
- The R/T position of an audio control panel Push-to-Talk (PTT) switch (see above)
- The PTT (push to talk) position of a hand microphone switch

Note: The R/T switch on the audio control panel also is used to transmit via cockpit interphone when pushed to the INT position. The switch is spring-loaded to the center (off) position. There is no “hot” microphone feature for the UPS B747-44AF (except for the signal to the CVR).

When the MIC CALL switch is pressed, a white light illuminates for the selected transmitter, and any other MIC light that was previously illuminated will extinguish. This action will also select that receiver audio on, if not previously selected on manually, and the volume level can be adjusted as required (the button does not have to be pushed in to gain volume access for a selected transmitter). Additional receivers can be monitored by pushing in the volume knob for the associated receiver and rotating the knob to the desired level.

Radio systems are monitored using headphones or speakers (adjusted through the speaker volume control knob). An oxygen mask microphone is enabled and the boom microphone disabled, when the oxygen mask left stowage door is opened. The oxygen mask microphone is disabled and the boom microphone enabled, when the left oxygen mask stowage box door was closed and the RESET/TEST switch on the stowage box is pushed.

### Microphones

There are three different microphones available to each pilot for transmissions on selected radios; the hand-held microphone, the boom microphone on the headset, and the oxygen mask microphone. Activation of the hand-held PTT, a control wheel microphone/interphone or audio control panel mic/interphone switch transmits on the system selected for use at that station.

### Stuck Microphone Protection

On the ground, any VHF radio transmitting for longer than 35 seconds is disabled following annunciation of a warning beep. The radio is re-enabled when the microphone switch for that radio is released.

### Aircraft Communication Addressing and Reporting System (ACARS)

ACARS data and voice modes provide automatic and manual means to transmit and receive operational, maintenance, and administrative information between the aircraft and a ground station. ACARS is operational when electrical power is established and is accessed by selecting the ACARS prompt on the CDU main menu.

ACARS communicates through VHF L/C/R or SATCOM and/or HF L/R. If ACARS is not available due to lost communication, information to be transmitted is stored, and then transmitted automatically when communication was regained. VHF L/C/R or HF L/R data mode can be selected and deselected by pushing the frequency transfer switch on the radio tuning panel.

### Satellite Communications (SATCOM)

ACARS uses the SATCOM system when the aircraft is beyond VHF communication range. Switching between VHF and SATCOM is automatic. ACARS data is controlled through the control display units (CDUs). The SATCOM system also provides voice communications. Voice transmission is controlled using the CDUs and audio control panels. Calls could be initiated using the CDU. The SATCOM CDU control pages display by selecting SAT on the MENU page.

## Flight interphone

Communication between the two crew members when the oxygen masks are donned can be conducted via the flight interphone system.

### Hot Microphone [Hot Mic]

There is no 'hot mic' function on this operators B747-400, pilots must communicate (through the microphone in their oxygen mask) by pressing the INT position on the control yoke or the INT position on the audio control panel, and listening to each other via the cockpit overhead speakers.

One factor when dealing with the QRH and running checklists is that the B747-400 does not have a hot microphone function. Without a hot microphone function, this aircraft requires either pushing the INT position on the control column microphone switch or the INT position on the audio control panel, and listening to each other via the cockpit overhead speakers.

Either way, one hand is required for to transmit on intercom. If a pilot has a QRH in one hand and a flashlight in the other, the pilot is required to release one of the items to key the microphone. These factors in a high workload situation do not contribute to a simplified emergency planning CRM philosophy.

## 1.10 Aerodrome Information

---

### 1.10.1 UAE eAIP Effective Sept 2010

As published in the UAE's eAIP. The aerodrome is CAT 10 ARFF.

Aerodrome information: UAE/DXB/RWY12L

UAE AIP Information as published for DXB RWY 12L

LOC RWY 12L/1.3°E (2005)/CAT III/E/4IDBL 110.100 MHZ/24/LAT: 251444.6N / LONG: 0552304.3E

RWY 12L ILS Localiser Frequency

LOC RWY 12L 1.8°E (2012) CAT III/E/4	IDBL	110.100 MHZ
--	------	----------------

Table 9 RWY 12L ILS Localiser and Frequency

## 1.11 Flight Data Recorders

---

### 1.11.1 Digital Flight Data Recorder

On September 10, 2010, the Safety Board's Vehicle Recorder Division received the following FDR:

Recorder Manufacturer/Model: L-3 Communications Fairchild Model FA2100, 256 Word  
Recorder Serial Number: 00487

The recorder had extensive heat and impact damage



Picture 3 Damaged Flight Data Recorder in the Recovered condition

The memory was removed from the unit and readout by using a surrogate recorder. Data were downloaded normally and all data was successfully recovered.



Picture 4 – The FDR Memory Connected to the Surrogate Recorder

### Digital Flight Recorder Description

This model DFDR records aircraft flight information in a digital format using solid-state flash memory as the recording medium. The FA2100 can receive data in the ARINC 573/717/747 configurations and can record a minimum of 25 hours of flight data. It is configured to record 256 12-bit words of digital information every second. Each grouping of 256 words (each second) is called a subframe. Each subframe has a unique 12-bit synchronization (sync) word identifying it as either subframe 1, 2, 3, or 4. The sync word is the first word in each subframe. The data stream is "in sync" when successive sync words appear at proper 256-word intervals. Each data parameter (e.g. altitude, heading, airspeed) has a specifically assigned word number within the subframe. The FA2100 is designed to meet the crash-survivability requirements of TSO-C124a.

### Cockpit Voice Recorder

On September 10, 2010 the NTSB Vehicle Recorder Division's Audio Laboratory received the following CVR<sup>49</sup>:

Recorder Manufacturer/Model: L3 Communications Model FA2100-1020-00

Recorder Serial Number: 474207

The Cockpit Voice Recorder was downloaded, reviewed and transcribed following NTSB standards and approved procedures.

### Recorder Description

The L3 Communication FA2100 is a solid-state CVR that records 2 hours of digital cockpit audio. The recorded audio data contains 3 files of 8 KHz sampled audio for 1) the Pilot, 2) Co-pilot, and 3) "Spare" audio panels. A fourth file contains 16 KHz sampled audio from the Cockpit Area Microphone (CAM).

All four channels had a duration 02:04:13.7 (HH:MM:SS.s).

### Recorder Damage

Upon arrival at the audio laboratory, it was evident that the CVR had sustained significant heat and fire damage to the exterior. However, upon disassembly of the crash-hardened module, the internal circuit

---

<sup>49</sup> Model and serial number were provided by UPS records. The data plate on the recorder was fire damaged and not legible.

cards and memory chips were found in pristine condition. The temperature sensing stickers applied to both circuit cards had not been activated<sup>50</sup>.

#### Audio Quality

The CVR recording quality was rated as Good to Excellent<sup>51</sup> for all channels. Channel designations and quality are listed in the table below.

Channel Number	Content/Source	Quality
1	Spare/Observer	Excellent <sup>52</sup>
2	Co-pilot's Audio Panel	Excellent
3	Captain's Audio Panel	Excellent
4	Cockpit Area Microphone	Excellent

Table 10 CVR Recording Quality

#### Timing and Correlation

Timing on the transcript was established by correlating the CVR events to common events on the Flight Data Recorder (FDR). Specifically, several radio transmissions that the aircraft made were correlated to the radio transmit microphone key parameter from the FDR.

The following relationships were established:

$$1) \text{ CVR Elapsed Time} + 212829.6 = \text{FDR Sub-frame Reference Number (SRN)}$$

Where:

CVR elapsed time is the total number of seconds since the beginning of the CVR recording

SRN<sup>53</sup> is the elapsed time (in seconds) since the beginning of the FDR download.

$$2) \text{ SRN} - 149387.99 = \text{Gulf Standard Time (GST) (based on FDR time-of-day clock) in seconds after midnight.}$$

The times presented in the attached CVR transcript, and the times associated with the parametric data from the FDR, are presented in Gulf Standard Time (GST) time zone, based on the time-of-day clock recorded as a parameter on the FDR. The offset from UTC to GST is +4 hours.

A discrepancy of approximately 3 seconds over the duration of the flight existed between the DFDR SRN, and the DFDR recorded parameter for GMT time. As a result, there is some uncertainty in the correlation from CVR Elapsed Time to GST, of up to approximately 3 seconds.

<sup>50</sup> These stickers activate (turn black) when exposed to temperatures at or above 360° Fahrenheit / 182° Celsius

<sup>51</sup> See attached CVR Quality Rating Scale.

<sup>52</sup> Excellent Quality: Virtually all of the crew conversations could be accurately and easily understood. The transcript that was developed may indicate only one or two words that were not intelligible. Any loss in the transcript is usually attributed to simultaneous cockpit/radio transmissions that obscure each other.

<sup>53</sup> Subframe Reference Number



## 1.12 Wreckage and Impact Information

---

### 1.12.1 Background Information

The aircraft crashed nine nm south of DXB onto a military installation, narrowly avoiding a large urban conurbation, Silicone Oasis, south eastern Dubai.

The aircraft attitude at impact was a shallow descending turn to the right. Judging by the ground scars and debris path, the aircraft was almost at a level attitude at first contact. The debris path was linear, covering a distance of 620 meters, spread along the heading at the initial point of impact continuing on the impact heading of 243°.

The aircraft initial impact was on a perimeter service road, the RH wing contacted several buildings, and the engines separated, before the fuselage went through a group of service sheds. The bulk of the airframe mounted a sand bank, where the major structural assemblies and tail section separated.

The wings, center and forward fuselage were spread over a 300 meter area, with the cargo, some of the aircraft systems and associated on board equipment distributed around the debris field.

The majority of the wreckage was damaged in the post-accident fire.



Photo 1 View looking over Nad Al Sheba military base towards the residential area of Silicon Oasis, Dubai

### 1.12.2 Accident Scene Description

The accident aircraft impacted the ground inside the confines of Nad Al Sheba military base nine nautical miles south of Dubai, United Arab Emirates. During the impact, the aircraft destroyed an unknown number of buildings and trucks. There was an extensive post-crash fire which consumed the bulk of the aircraft and remaining cargo.



Photo 2 Overall view of the debris field, looking back towards the initial impact location

The debris field was classified into two distinct zones:

- Zone #1: Where the debris was subjected to a post-crash ground fire
- Zone #2: Where the debris was found outside of the post-crash fire zone.

The flight, which had departed from the Dubai international airport was fully loaded with cargo on the main deck cargo compartment and the below deck cargo compartments. An account of the cargo container types and their positions on the aircraft can be found in the cargo group's factual report<sup>54</sup>

The cargo containers and pallets were all destroyed by the impact forces and post-crash fire. The few recognizable parts of the containers and pallets were base plates and a few doors. All of the pieces identified as being parts of containers and pallets were examined for recognizable in-flight fire damage. Due to the severe post-crash fire damage to these components, no particular in-flight fire characteristics were observed. The contents of the cargo containers were spread throughout the debris field, both inside and outside the post-crash fire zone. Details about the cargo contents, as declared by the shippers and contained within the cargo manifest, can be found in the cargo group's factual report.

### 1.12.3 Wreckage Examination

The on-scene wreckage examination focused on items found on the border and outside of the main post crash fire zone. These items were aircraft structure with thermal damage and soot patterns believed to be consistent with damage occurring prior to the aircraft's impact and not artefacts of the post-crash fire. The locations from where these items originated on the aircraft are shown in the following two diagrams of the aircraft's outline. Each of the identified items is numbered on the two diagrams including whether the item was internal aircraft component or external.

---

<sup>54</sup> See Appendices



Photo 3 Cargo container base plate [LH] and cargo door [RH]

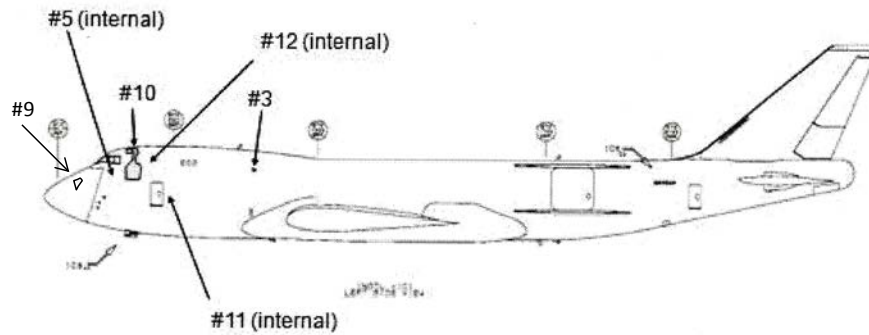

Left hand side outline of accident aircraft depicting locations of identified items

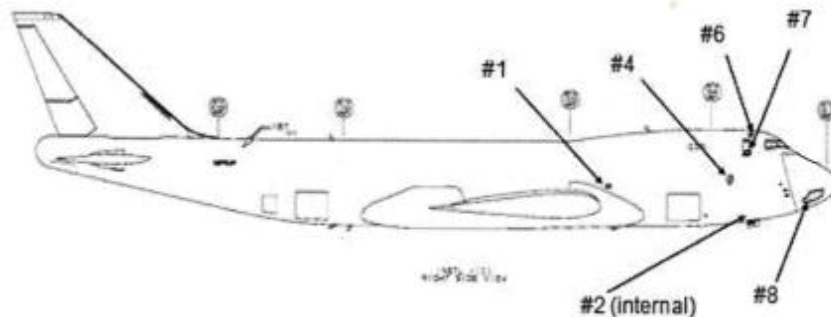

Right hand side of accident aircraft depicting locations of identified items

#1: Fuselage observation window	#7: Hinge casting
#2: Cover from power distribution center	#8: Part of nose door (lower)
#3: Fuselage skin	#9: Part of nose door (upper)
#4: Fuselage skin & structure	#10: Portion of structure and fuselage skin
#5: Structure with pulley attached	#11: Stair to flight deck

#6: Fuselage skin with smoke shutter cut-out

#12: Shelf from galley cabinet

List of items identified in figures #1 - #6

#1: Fuselage observation window

The piece of the fuselage observation window, or viewport, had sooting around the viewport opening and the viewport seal was charred and reduced to a white powder. An area of the green primer had evidence of thermal degradation of the primer paint. The level of damage sustained by the viewport window and seal in contrast to the level of damage to the surrounding material and primer paint is consistent with the thermal exposure having occurred while the viewport was covered by the bezel leaving only the window portion exposed to the interior of the main deck cargo compartment. This viewport was located on the right side of the aircraft at approximate station number 840, which is also cargo position 6R



Photo 4 Fuselage Viewport

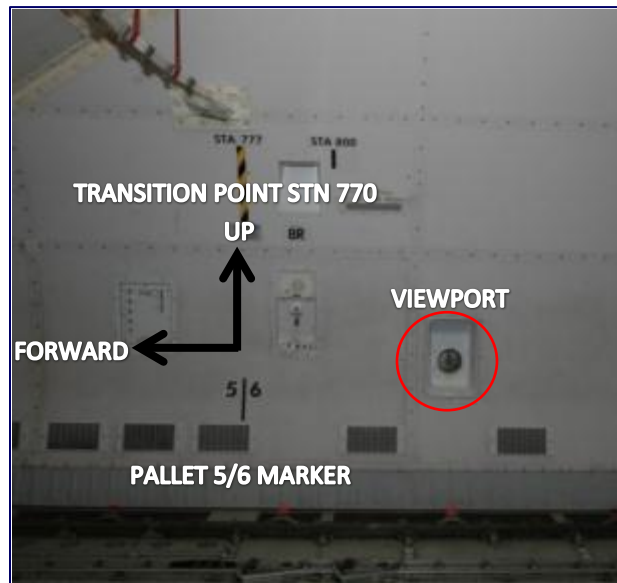

Photo 5 Viewport (with trim bezel) in exemplar aircraft.

#2: Cover from power distribution center

The cover from the power distribution center right was found to have a light sooting on the exterior and interior surfaces. There was no thermal degradation associated with this component which would have been located at approximately body station 420 on the lower lobe.

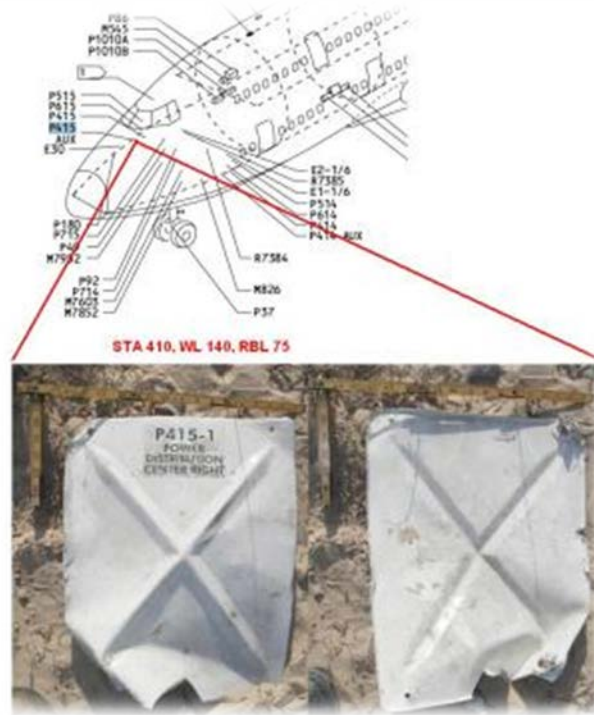

Photo 6 Cover from power distribution center

#3 Fuselage skin

The fuselage skin piece was a heavy gauge (~.125") skin piece from fuselage. On the interior surface there is sooted corrosion inhibiting compound (CIC) around a protected surface which became exposed after the aircraft breakup. On the exterior surface of this part is a portion of lettering identified as belonging to the letter "V" from the text "Worldwide Services" displayed along the upper lobe on the left side of the aircraft.



Photo 7 Recovered Fuselage skin section [LH]. Exemplar aircraft exterior [RH]

#### #4 Fuselage skin and structure

The fuselage skin and structure piece originated from the right hand side of the aircraft's fuselage skin between station 460 and 488 and somewhere between stringer 17 and 24. This item was found to have soot trapped within impact induced folds.



Photo 8 Fuselage skin and structure piece

#### #5 Structure with pulley

The portion of structure with pulley was found to have heavy sooting on one side while being relatively devoid of soot on the other. This item would have been at a location described by, LBL 40, WL 302, station 287 25sv0012.



Photo 9 Structure piece with pulley (showing both sides)

#6: Fuselage skin with smoke shutter cut-out

The portion of fuselage skin contained the cut-out for the flight deck's smoke evacuation shutter. The actual smoke shutter had separated from this portion of the fuselage. A very thick soot trail almost resembling tar extended from the cut-out location aft to the end of the recovered portion of fuselage.



Photo 10 Fuselage skin piece with smoke shutter cut-out (interior on the left, exterior on the right)

A photo of an exemplar smoke shutter and cut-out is shown below.



Photo 11 Smoke shutter fuselage cut-out from exemplar aircraft

#7 Hinge casting

The hinge casting (PN:65b14006-3) piece was found with soot on one side and clean on the other. This item belonged to the escape slide mechanism on the right side of the upper lobe just aft of the flight deck



Photo 12 Hinge casting component

#8 Portion of nose door (lower)

This portion of the nose door was from the lower part of nose door on the right hand side near station 180. This item exhibited localized charring of the primer and some burnt insulation in the area shown circled in



Photo 13 Portion of nose door (lower right hand side)

#9 Portion of nose door (upper)

This portion of nose door was from the upper portion of the door on the left hand side approximately between stations 160 to 200. This piece exhibited some localized discoloration of primer shown circled above.





Photo 14 Portion of nose door (upper)

#### #10 Portion of structure and fuselage skin

This recovered assembly of structure and fuselage skin originated from the left hand side, upper section 41, Station 360 – 420. There was heavy fire damage in the form of charred insulation and primer paint between stations 360 and 380 stopping at the level of the upper deck floor. The fire-damaged area contained TCAS coax cables and an air vent hose.

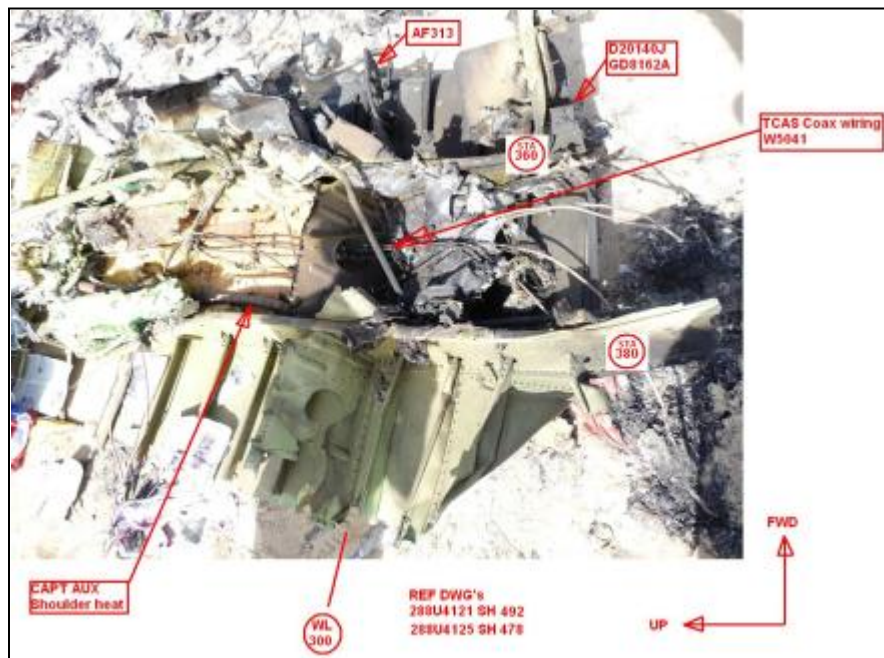

Photo 15 Recovered assembly of structure and fuselage skin

#### #11 Stairs to the flight deck

The stairs to the flight deck extend from the floor of the main cargo deck up to the upper deck. The stairs have sooting at the top portion of the stairs which then tapers off towards the bottom. This soot graduation is consistent with a stratified smoke layer existing within the main cargo deck.

The demarcation of sooting on the stairs suggests a smoke layer extending to the height shown by the dotted line in photo 17 below.



Photo 16 Stairs to the flight deck



Photo 17 Exemplar interior showing stairs to the flight deck and a dotted line showing the level of the smoke layer

#12 Shelf from galley cabinet (figure)

The shelf originated from the cabinet behind flight deck bulkhead. The shelf has heavy soot stains around outlines of items that had been sitting on the shelf during flight.

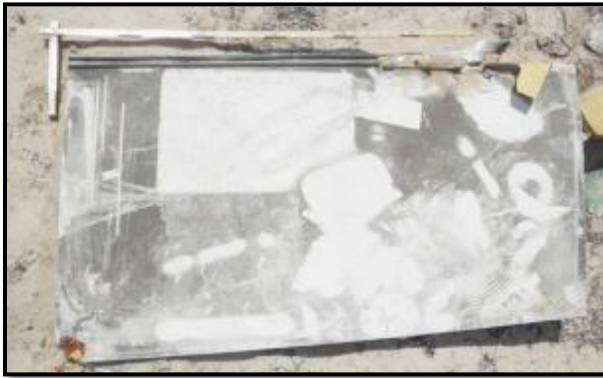

Photo 18 Shelf from galley cabinet [LH]/ Galley shelf behind flight deck bulkhead in exemplar aircraft [RH]

Cargo Identified In the debris

The cargo identified on scene included clothing, machined parts and subassemblies, flashlights, gun parts, costume jewellery, cases for electronic equipment, USB flash drives, un-populated circuit boards, espresso makers, automotive entertainment and navigation systems, bike frames, pellets for injection moulding, wrist watch components, rubber bracelets, cell phones, MP3 and MP4 players, mannequin heads, wigs, shoes. No items posing a flammable fuel load or capable of acting as an ignition source were visually identified except for batteries and battery containing devices.

The following photographs are of batteries and battery containing devices found in the debris



Lithium-ion battery pack.



Fire damaged remains of battery pack with a fractured cell



Additional battery pack remains [LH]/D-Cell size lithium primary batteries. Photo shows fire damaged and undamaged batteries [RH]



Lithium primary button sized flat cell batteries (watch style) with small circuit board



36-cell lithium-ion battery pack with thermal damage.



36-cell lithium-ion battery pack with multiple vented cells



Lithium-ion, mobile phone type battery



Intact and fire damaged Panasonic batteries (2-pack Li-ION set)[LH]/Mobile phones and batteries [RH]



Personal electronic device with battery inside [LH]/Lithium-ion battery pack [RH]

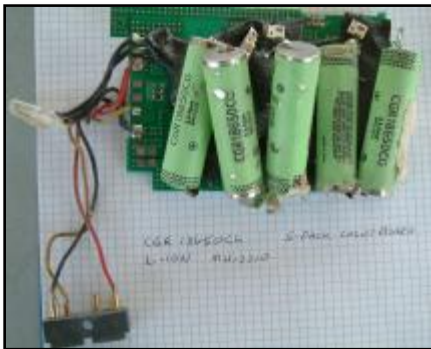

Lithium-ion battery packs - LH and RH

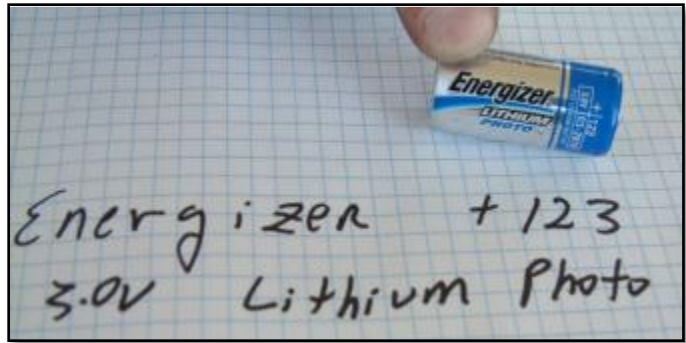

Lithium primary (CR123 type) battery



Electronic cigarettes containing lithium primary batteries<sup>55</sup>



Lithium-ion polymer type battery pack [LH]/ Lithium-ion polymer type battery pack with thermal damage [RH]

<sup>55</sup> Electronic cigarettes containing lithium primary batteries. These devices have no on/off switch. Inhalation activates the atomizer heating coil to heat the liquid in the cartridge and convert the liquid to a vapour. This action uses differential pressure only.

### 1.13 Medical and Pathological Information

---

Both crew members were recovered from the crash site and removed to the medical and pathological facilities of the Dubai Police Forensics Department where autopsies were performed.

Full forensic examinations were performed following the accident with fluid and tissue samples screened for the following

- › Alcohol
- › Psychoactive substances
- › Toxic substances
- › Percentage of Carboxyhaemoglobin (COHb) in the blood

#### 1.13.1 Captains Medical Data - Dubai Police Forensics Department

- › Blood sample revealed ethyl alcohol with a concentration of (11 mg/dl).
- › Muscle sample revealed an ethyl alcohol with a concentration of (12 mg/100 g).
- › Blood sample from the Captain indicated a Carboxyhaemoglobin (COHb) concentration of 49.5%.<sup>56</sup>

#### 1.13.2 First Officers Medical Data - Dubai Police Forensics Department

- › Tissue samples did not reveal presence of ethyl alcohol.
- › No prohibited narcotics substances indicated
- › No toxic substances from chemical, natural, alcoholic or volatile sources were indicated.

#### 1.13.3 Secondary Medical Samples Sent to the FAA Civil Aerospace Medical Institute (CAMI)

In accordance with international best practice, specimens of forensic material were requested and delivered to the Federal Aviation Administration (FAA) representative in the UAE by the GCAA.

This material was then sent by the FAA representative to the FAA Civil Aerospace Medical Institute (CAMI).

The CAMI laboratory performed an independent analysis of the specimens sent by the FAA to the institute. The CAMI specimen analysis indicates the presence of ethanol in samples from the captain and first officer; however, their report states that the ethanol reported in these cases are from post-mortem ethanol formation and not from the ingestion of ethanol.

The Captain's specimen indicated 20 (%) Carbon Monoxide detected in Blood.

The First Officer's specimen was not tested for carbon monoxide.

---

<sup>56</sup> This is considered a significant percentage that could lead to coma followed by acute respiratory failure followed by cardiovascular collapse. The incapacitation of the pilot-in-command is attributed to inhalation of toxic gases [carbon monoxide] produced by the fire.



## 1.14 Fire

### 1.14.1 In-flight Phase

As detailed in other sections of this report, a cargo fire originating on the main cargo deck breached the cargo compartment liner, severely damaging the control cable support trusses, oxygen system and other essential systems impairing the ability of the crew to safely operate the aircraft for the duration of the flight from the time of the first fire indication.

Due to the cargo compartment liner failing to operate as an effective fire and smoke barrier, the supernumerary and cockpit areas filled with continuous smoke. The smoke did not abate for the duration of the emergency.

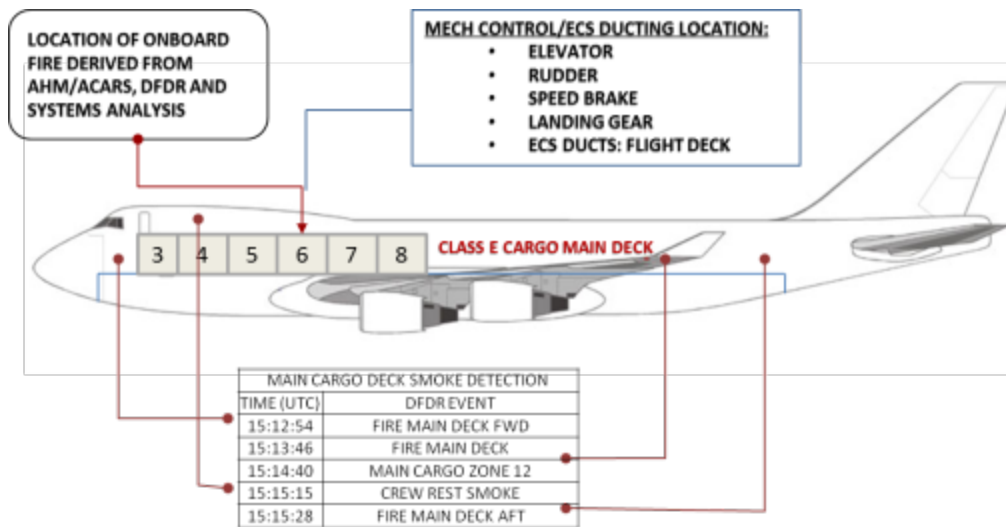

Figure 28 Fire Warning - Crew Alerts

### 1.14.2 Ground Phase

The majority of the aircraft inside debris zone#1 was destroyed by the post-accident fire resulting from the rupture of the fuel tanks, the subsequent dispersal of the available fuel of approximately 90,000 liters/24,000 US gallons, over a wide area followed by the ignition of the fuel.

The fire covered a significant area as the fuel dispersed.

## 1.15 Survival Aspects

This section is divided into two phases: (i) the in-flight phase and (ii) the ground contact phase.

Due to the fire damaging the critical systems required to operate the aircraft and the crew's survivability systems damage, the damage incurred in-flight is considered sufficiently significant to be considered a survivability issue.

### 1.15.1 Inflight Phase

Protection of the critical systems and equipment from the cargo fire damage, in particular the failure of the fire protection liner to limit the exposure of the supplemental oxygen system [SOS] to the cargo fire is a causal factor in the disruption of the oxygen flow to both crew members.

The oxygen system damaged by the fire, stopping the flow into the LH mask and reduced capacity for the remaining flight to the RH mask.

Several aspects of the investigation centred around the CVR statements from the crew concerning the amount and volume of continuous smoke or fumes entering the cockpit area and the increasing temperatures in the cockpit area. The inability by the crew to view the instruments or any of the radio panels had a direct consequence of the survivability of the flight.

#### 1.15.2 Ground Contact/Aircraft Disintegration

Loss of Control Inflight/Uncontrolled Flight Into Terrain. The aircraft was in a slight nose down, right hand low attitude in a shallow descending turn when the initial substantial ground contact occurred.

The velocity of the aircraft, the terrain and the deceleration loads and subsequent disintegration of the aircraft, combined with the crew's reduction of the available survivable space and environment precluded the possibility of surviving the first substantial impact or the consequential fire.

This accident was not survivable.

### 1.16 Testing and Research

---

Following the accident due to the uncontained fire on the main deck of the aircraft, several lines of investigation were opened to investigate and identify the initiating and causal factors, correlate the digital data available in conjunction with various other source to develop a baseline for further analysis.

The following is a summary of the actions taken by the GCAA and supporting investigation agencies to develop and understand various operational requirements, human factors considerations, safety and risk factors.

This information was then collated, analysed against the findings and used to validate the conclusions and safety recommendations.

#### 1.16.1 Flight Testing - Boeing 747-44AF / Boeing 747-45EF

Several flight tests have been conducted using a representative Boeing 747-44AF or Boeing 747-45EF aircraft.

The purpose of the flight testing has been to verify operational requirements, systems functioning, human performance and baseline CVR data for later analysis.

This testing included the check and verification of the flight deck ergonomics, crew accessibility of the emergency equipment within the flight deck, including the donning of the mask/goggles and to record the oxygen mask function for further CVR analysis, pack function and certain operability functions not readily available from the published data.

#### 1.16.2 Fire Testing – Batteries and Cargo Containers

The investigation conducted tests to examine the fire load contribution of lithium and lithium-ion batteries, and large scale testing of the burning characteristics of cargo pallets and containers using full scale fires to quantify the cargo fire behaviour. The objectives were to determine baseline quantifiable data to support recommendations for fire safety improvements. Testing was conducted at the Fire Research Branch of the Federal Aviation Administration's Technical Center in Atlantic City, New Jersey, and at the Fire Research Laboratory of the Bureau of Alcohol, Tobacco, Firearms and Explosives [BATFE].

The full reports of these tests are included in appendices of this report.

### 1.16.3 Fire Load Contribution of Lithium and Lithium-ion Batteries<sup>57</sup>

Lithium batteries have been in the spotlight for the past few years due to their possible involvement in aircraft cargo fires. Recently there have been two in flight fire accidents in which the involvement of lithium and lithium-ion batteries has come into question.

To date, the hazard posed by lithium and lithium-ion batteries has not been fully understood and quantified by the fire protection community. A material or assembly of materials, as is the case in batteries, can have many characteristics that play a role in its ability to pose a fire hazard.

From the tests involving batteries, the following conclusions were made:

- At the single-cell level, the energy release rate of lithium and lithium-ion type batteries is relatively small when compared to other ordinary materials.
- In addition to the energy release from batteries resulting in combustion, there is an associated mechanical energy release. This mechanical energy release is capable of compromising the integrity of packaging and creating incendiary projectiles.
- Lithium (primary) batteries tend to exhibit more energetic failures than lithium-ion (secondary) batteries.
- The total energy release of a box of 100 lithium-ion batteries can be fairly accurately predicted based on single battery cell calorimetry data.
- The thermal runaway of lithium-ion batteries is capable of spreading from cell to cell within a package of batteries.
- The thermal runaway of lithium-ion batteries is capable of causing adjacent combustibles to ignite.

### 1.16.4 Burning Characteristics of Aircraft Cargo Container Fires

The investigation has quantified the fire threat posed by cargo container fires by examining the overall energy output, growth rate and detectability of a fire originating within a container. Experiments were done to measure various characteristics of cargo container fires such as detectability, growth rate, and energy output.

Due to the great diversity of commodities being shipped and the shipping materials used to package those commodities, the baseline fire load for the cargo container fire tests was chosen to consist of ordinary cellulosic combustibles. Traditional construction (aluminium/Lexan) rigid containers as well as collapsible design (polypropylene) containers were used to evaluate the role of the container type and construction material on the fire's characteristics and potential for smoke masking.

Regulations in Title 14, *Code of Federal Regulations* (14 CFR) addresses liner materials (14 CFR 25.855) in Class C compartments and the certification of cargo compartments with aircraft-based smoke detection systems (14 CFR 25.858). Conversely, there are few requirements regarding fire protection for the design and materials used on cargo containers and how they impact the fire protection systems built into the aircraft, namely the smoke detection system.

This portion of the study consisted of two test series, each with a different type of container (A2N and DMZ) to evaluate any delays in smoke egress from the containers from the time of the fire's initiation.

---

<sup>57</sup> Fire load is the amount of combustible material that can become involved in a fire.

Additionally, this portion of the study measured the time between when sufficient smoke egress from the container to activate an alarm and the time for the container fire to reach peak fire output.



Figure 29 A2N Cargo Container Fully Developed Fire

### 1.16.5 Rigid A2N Container Tests

Two tests were performed using the A2N type of rigid cargo container (photo 1). This container type is constructed from aluminium and polycarbonate and has a fabric roll-up door.

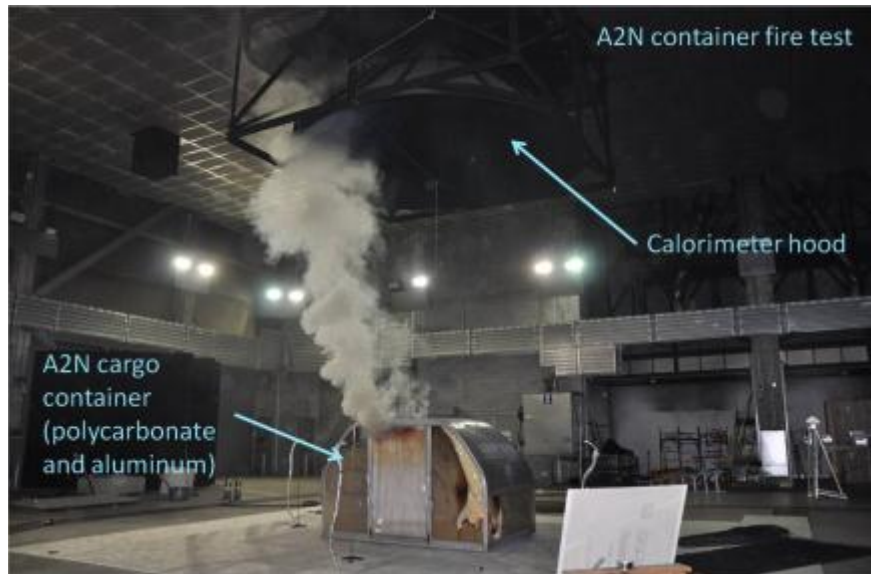

Photo 1 - A2N Cargo Container

### 1.16.6 Collapsible DMZ Container Tests

Two tests were performed using the DMZ type of collapsible cargo container (Photo 2). This container type is constructed from corrugated polypropylene and while in use is covered with a lightweight impermeable cover. This container type was chosen because it was likely to exhibit the greatest delay in becoming a detectable fire and because of the material of construction which would provide the most contribution to the fire load.



Photo 2 - NTSB DMZ Cargo Container fire depicting a polypropylene cargo container burning at a rate of 8.45MW, 132 seconds after becoming detectable to an aircraft-based smoke detection system.

### 1.16.7 Cargo Container Study Results

The large scale tests involving cargo containers established the total energy release and peak energy release rate for a standard fire load using two different types of containers. Although the standard fire load chosen may not be entirely representative of what can be found in a container of commercial cargo, it is a start for assessing the threat to an aircraft from a cargo container fire. It was observed that, based on container design and method of usage while in operation, there can be a vast difference in fire performance from one container type to another. This difference was observed in both the time that it took for a fire inside a container to become detectable and in the overall size and growth rate of the fire.

In the two tests with the A2N containers, sufficient smoke to activate an alarm began to exit the containers at 3 minutes 19 seconds and 2 minutes 30 seconds, respectively for the two tests, after smoke was visible within the containers. In the two tests with the collapsible DMZ containers, sufficient smoke to activate an alarm began to exit the containers at 18 minutes 30 seconds and 5 minutes 10 seconds, respectively for the two tests, after smoke was visible within the containers.

The time interval between the time when sufficient smoke to trigger an alarm was exiting the containers to the time when the container fires were at their peak energy release rates was significantly different for the two types of containers tested.

For the A2N containers, this time interval was 7.5 and 10.5 minutes, while for the collapsible DMZ containers, this time interval was 2.2 and 1.9 minutes.

For the same fire load, the DMZ containers constructed out of fire-resistant polypropylene exhibited twice the peak energy release rate and total energy output than the A2N containers constructed out of aluminium and polycarbonate.

From the tests involving cargo containers, the following conclusions were made:

- Differences in container design and materials have a significant effect on fires originating within them.
- Container design has a significant effect on the time it takes for an internal fire to become detectable to a smoke detector outside the container.
- Container construction materials have a significant effect on the total fire load and energy release rate of a cargo fire.
- The time it takes for a fire detection system to detect a fire originating within a cargo container may easily exceed the 1 minute time frame specified in Title 14 *Code of Federal Regulations* (CFR) 25.858(a).
- The growth rate of container fires after they become detectable by the aircraft's smoke detection system can be extremely fast, precluding any mitigating action and resulting in an overwhelming fire.

### 1.16.8 Lithium Battery Testing

Testing conducted by the FAA William J. Hughes Technical Center (FAA Tech Center) indicates that there are particular propagation characteristics associated with lithium batteries.

Overheating has the potential to create thermal runaway, a chain reaction leading to self-heating and release of a battery's stored energy.

In a fire situation, the air temperature in a cargo compartment fire may be above the auto-ignition temperature of lithium.

For this reason, batteries that are not involved in an initial fire may ignite and propagate, creating a risk of a catastrophic event.

The existence and magnitude of the risk will depend on such factors as the total number and type of batteries on board an aircraft, the batteries' proximity to one another, and existing risk mitigation measures in place, which can include the type of fire suppression system on an aircraft, appropriate packaging and stowage of batteries.

#### Small Scale Battery Testing

Onsite testing of the various cargo fire scenarios comparing the latent cargo load's thermal energy [cardboard boxes] in latent thermal load of the cardboard boxes and lithium battery indicated that the time for release of the total energy was longer for the batteries/boxes, but that the overall thermal release [area under the graph] was relatively consistent.

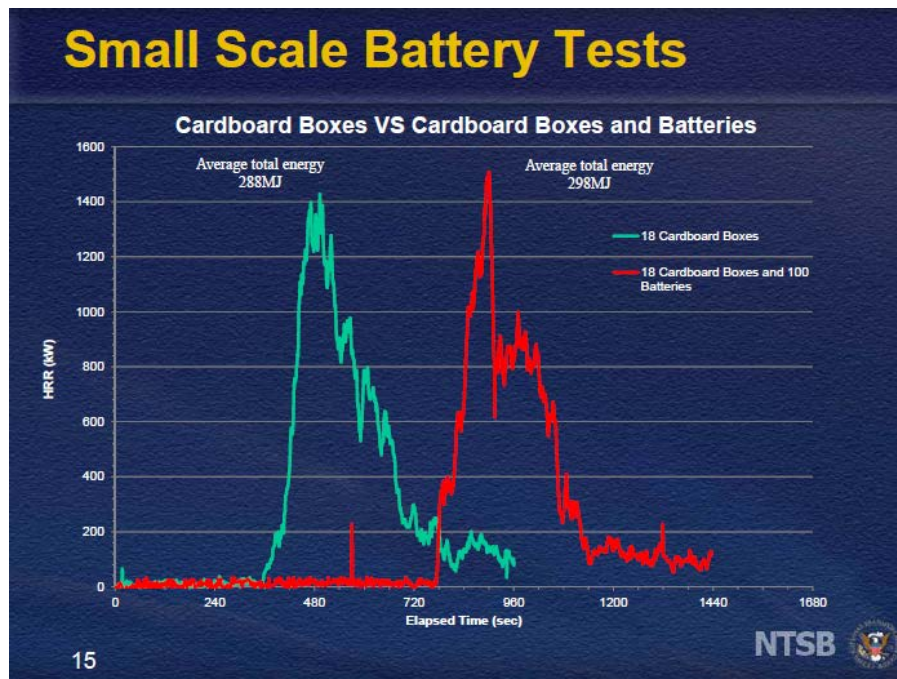

Figure 30 Battery Testing - Thermal Energy Release

#### 1.16.9 Aircraft Systems Testing - Crew Oxygen Delivery System Elevated Temperatures

Early in the investigation it was apparent that the oxygen supply stoppage to the LH side, Captains' oxygen mask was a significant factor. The cessation of the Captains oxygen supply was abrupt and without any prior indications to the crew that the oxygen supply was depleted or damaged.

According to the certification standards, the aircraft was designed and manufactured to provide sufficient redundancy and mitigation in the fire protection. The philosophy is to provide protection of the aircraft's critical systems, including the crew's vital systems required for crew survivability.

Due to the post impact fire, no identifiable parts of the crew oxygen system were identified in the wreckage. However, derived analysis of the CVR, in conjunction with a detailed engineering investigation examining the oxygen supply routing, with the ACAR's data indicating the probable location of the fire and the intensity of the thermal release associated with this cargo fire, clearly indicate that a fire on the

main deck with a failed cargo compartment liner will expose the oxygen system CRES tubes to high, sustained elevated temperatures.

The CVR investigation indicates the Captain's oxygen mask stopped delivering oxygen approximately six minutes after the fire alarm was heard. The F/O's oxygen supply continued to function when the left hand or Captain's supply abruptly stopped with no prior indication of an oxygen supply problem.

The systems group performed an oxygen systems architecture investigation analyzing the oxygen supply routing from the forward cargo hold through to the distribution networks and the final stage of the oxygen delivery to the crew's oxygen stowage box and masks

The crew, and in particular the Captain's oxygen supply is routed under the cockpit floor, the Captain's supplementary oxygen supply line runs transversely from the right-hand side to the left-hand side of the cockpit, which positions the supply line tubing above the main deck cargo hold, above the cargo compartment liner.

The investigation concluded that it may have been possible that elevated temperatures affected the oxygen delivery to the MXP147-3 oxygen mask stowage box and caused a failure of the oxygen system supply.

The oxygen mask was the indicated point of failure for the oxygen delivery, although it was not established if this was the origin of the failure. The investigation was required to establish all of the causal factors that could influence the oxygen delivery to the crew masks. This was achieved through a process of testing and empirical analysis.

The primary concern was to determine if the mask had failed, or the system designed to supply the supplementary oxygen to the mask had failed.

It was concluded that this could not be determined through theoretical thermal analysis modeling only and that the key components of the oxygen delivery system would need to be replicated in a controlled environment and tested with air at high elevated temperatures supplied into a replicated oxygen delivery system.

The investigation team convened at the FAA Technical Center, Atlantic City to perform elevated temperature testing of the oxygen delivery system and the associated mask function performance tests.

The testing was specific to the known data concerning the abrupt stoppage of the LH/Captains oxygen supply.

Based on the CVR sound spectrum analysis, the captain's oxygen mask was in the 100% position.

Zodiac Aerospace/Intertechnique Aircraft Systems produced three masks with part numbers MC10-25-104. Each mask was assembled to the same production modification specification of the type used on the accident aircraft.

The associated Mask Stowage Box [MSB] part number MXP147-3 was also supplied to specification.

These were the masks/MSBs used in this mask functional testing.

A Simulated Breathing Device [SBD] was designed and assembled to replicate the rate, exhalation/inhalation pressure and volume of air exchange of a typical human breathing pattern.

The oxygen supply was routed through a variable temperature furnace capable of replicating the temperatures of a cargo fire of between 1000-1400°F/538-760°C.



Compressed air was introduced into the system; the air was heated to representative thermal load in the furnace and then delivered through a CRES tube connected by the design standard metallic connector used on the B744F.

Downstream of the connector the oxygen was routed through the MXP147 mask stowage box, and then through the DTS4032 oxygen hose to the mask.

The mask air volume was supplied via the SBD.

The air system outlet connector was attached to an anatomically correct mannequin which was connected to the simulated breathing device bellows with a metallic tube leading up to an aperture representing the oval oral cavity.

The uniform volume bellows connected to the mannequin to simulate normal human inspiration and expiration by volume.

To secure the MC10-25-104 oxygen mask with the oval oral cavity, additional silicone sealant was applied to represent a full fit, form and function seal between the anterior, ventral, aspect of the head from the forehead to the chin and the oxygen mask.

Two of the elevated temperature tests resulted in failure of the 60B50059 flexible hose, which is connected directly to the oxygen mask stowage box.

The testing was conducted in a controlled environment with the system components exposed to the ambient room temperatures. This resulted in components, for example tubing or fittings downstream of the heating, would substantially dissipate the effect of the heating to convective heat loss [to atmosphere]

A test was also performed to determine how the mask and pressure switches behaved as the pressure to the mask box was slowly reduced. At approximately 25 psi and lower it was considered difficult to continue normal at rest breathing. The pressure switch did not change state until the pressure was reduced to approximately 14 psi. Crew Oxygen Delivery System Elevated Temperatures Testing was completed at the FAA Tech Center.

A working model was developed to determine if the mask would fail if exposed to higher temperature level than the TSO requirement.

The mask performed according to the TSO fit, form and function requirements.

Verification of the oxygen system functional test under elevated temperatures was completed at the testing facilities in conjunction with systems specialist engineers from the NTSB, FAA and the operator of the accident aircraft.

A test was performed to determine the amount of pressure loss at the output of the aircraft oxygen pressure regulator with a failed 60B50059 hose, and concluded that the FO mask would continue to function for an unspecified, but finite time, as the venting supplementary oxygen levels decreased.

The test report summary is in Appendix B of this report.

#### 1.16.10 Oxygen Mask Test And Verification/Tear Down Inspection

Following the elevated temperatures testing, verification of the mask function post testing was completed at the manufacturers testing facilities in conjunction with systems specialist engineers from the NTSB, FAA and the operator of the accident aircraft.

No functional, material or operability issues were identified during the teardown inspection of the mask or during the functional checks using the manufacturer's calibration facilities.

The test report summary is in the appendices of this report.

#### 1.16.11 Boeing 747 Synthetic Training Device, Anchorage, USA

##### Anchorage Simulator Observations – Session #1 and #2

The investigation participated in an observational study at the operators training facility in ANC on September 13, 2010. The purpose of the study was to familiarize investigators with checklists and procedures related to smoke and fire scenarios that may occur in-flight. The simulator used for the observations as an FAA certified level D, B747-400 simulator. Three pilots who were type rated, current and qualified on the B747-400 participated in this study. In addition there was a simulator instructor and 4 observers from the operations/human performance group.

Selected observations from the sessions include:

The pilots involved in the exercise indicated that with the smoke goggles donned, it was difficult to find the switch to clear the goggles of smoke.

The instructor informed the crew that they should have completed the smoke fire and fumes checklist prior to completing the smoke removal checklist. Asked who would be in charge of communicating with ATC, both pilots indicated that the PM would do this.

If this was a single pilot operation, pilot #2 stated that the situation would have been “mind boggling” and he would have foregone the checklist. He also believed it would have been difficult to fly the approach without being able to see the instruments and having specific headings and altitudes.

The instructor who participated stated that he believed the smoke fire and fumes checklist to be the most complicated checklist and the scenario presented would have been a lot for any crew to do.

When the main deck’s cargo fire arm switch was armed, packs 2 and 3 were shut off. If pack 1 was turned off, pack 3 came back on as long as the pack 3 switch was still in the “norm” position. Page 8-10 of the smoke, fire, or fumes checklist stated to turn the pack 2 and 3 selectors to off. If this was completed and pack 1 failed without the crew recognizing this, pack 3 would not come back on.

It took approximately 28 seconds for the crew to don both the oxygen mask and smoke goggles. It took an additional 6 seconds for the crew to establish crew communications. The scenario was run two times and both times the headset was knocked off when donning the oxygen mask.

Pilot #3 stated that the smoke, fire or fumes checklist had lots of branches and was long. He said using the goggles and mask made it more difficult.

The full report on the Simulator Observations is in Appendix to this report.

#### 1.16.12 Boeing 747 Synthetic Training Device, Seattle, USA: Smoke Filled Environment, Checklist Verification, CRM/Human Factors and Aircraft Handling/Ditching Scenario Testing, USA.

Objectives:

- To document crew procedures and the aural and visual alerts/messages that occur during pack failure and main deck fire events.

- To document how crew performance is affected by modifying the font size of crew checklists and various lighting configurations, by removing outside visual references, and during single pilot operations.<sup>58</sup>

The investigation team using a Boeing 747 simulator performed various CRM functionality tests in a Smoke, Fire, Fumes [SFF] environment assessing intra-cockpit communications, crew performance, observations based on ambient visibility conditions, reduced visibility checklist testing and cockpit ergonomics in reduced visibility.

A rapid decent and ditching manoeuvre procedure was practiced to assess the survival ability of an attempted rapid decent and ditching using the accident aircraft profiles as a baseline.

The testing was instrumental in understanding human factors limitations in a SFF environment and validated the previous SFF recommendations contained in accident recommendation, safety reports and the independent publications of various aviation safety organisations.

The full report of this Simulator Observation is in the Appendix of this report.

#### 1.16.13 Boeing 747-F Familiarisation

On Tuesday September 14, 2010, the investigators were provided a familiarization of an operators Boeing 747-400 freighter at about 1315 ADT. A walk-around of the aircraft, under the guidance of a Check Airman, was conducted around the exterior of the aircraft prior to the group traveling to Louisville, KY.



Figure 31 Familiarization of a Boeing 747F

Photo documentation of the main cargo deck and the smoke detection system was performed. The Group was also provided a tour of the cockpit and supernumerary areas of the 747. Included was a familiarization of the 747 emergency equipment and its location, including the crew oxygen masks and smoke goggles, and main deck firefighting equipment.

---

<sup>58</sup> The purpose of this test was not to conduct a systems verification check or replicate any degraded flight control functioning.



Figure 32: Main Deck Emergency Equipment

From September 15 through September 16, 2010, the Group conducted additional interviews at the operators global operations center in Louisville, Kentucky.

On November 17, 2010, the Group participated in a flight test of a UPS B747-400 and documented, in flight, the audio/sound differences when positioning the oxygen mask system to various settings (normal, 100%, emergency) with and without the smoke goggles vent on. They also documented, on ground, the donning and accessibility of emergency equipment within the cockpit to flight crew members, and, in flight, the pack system logic as displayed on the FDR and in AHM data.

On December 1, 2010, the Group traveled to Seattle, Washington, to document crew procedures and the aural and visual alerts/messages that occur during pack failure and main deck fire events in a Boeing 747-400 simulator. The Group also documented how crew performance was affected by modifying the font size of crew checklists and various lighting configurations by removing outside visual references, and during single pilot operations. Investigators tested the range of the crew oxygen mask hose lines. A pilot exiting his/her flight deck seat while donning the crew oxygen mask cannot reach the emergency portable oxygen bottle (full-face mask and oxygen bottle located behind the left cockpit jumpseat) without removing their crew oxygen mask.



Figure 33: O2 mask with hose fully extended



Figure 34: Cockpit Portable Oxygen

From October, 2010, to January, 2011, the Group conducted additional follow-up interviews with UPS and FAA personnel, as well as next of kin interviews. B747-400 and UPS documents were collected during this period, and all receivable documentation was provided to the GCAA.

#### 1.16.14 Alternative Vision Systems for Smoke/Fumes in the Cockpit

Continuous smoke resulting from large inflight cargo fires as seen with this accident can lead to a situation where the operability of the aircraft and the safety of the crew can be compromised to such an extent that the possibility of recovering the aircraft cannot be a reasonable certainty.

The certification standards as they currently exist do not have a certification standard for continuous smoke removal

Regardless of the certification requirements, as a result of several inflight fires with continuous smoke events, there are alternative vision systems available to assist with smoke/fumes events

The investigation team tested various systems that enable a crew to view the immediate cockpit area and the PFD's

Two types of system are currently available:

Emergency Vision Assurance System [EVAS] is a self-contained system that includes a battery powered blower which draws smoke in through a filter, filtering out the visible particles, and out to a flexible air duct which is connected to an inflatable transparent envelope, called the Inflatable Vision Unit (IVU).

EVAS, the static Inflatable Vision Unit [IVU], a clear plastic closed loop pressurised system that provides a clear channel through smoke that allows the crew to view the

The pilot leans forward, placing his smoke goggles in contact with the EVAS clear window, providing an view of both primary flight displays instruments and the outside world.

Thermal Imaging Cameras. Two types were assessed, a thermal imaging camera and an infrared camera.

Both camera types can be helmet mounted as integral equipment for a full face smoke mask. The advanced systems have a small viewing screen mounted at eye level.

Currently there are no approved helmet mounted thermal/infrared integrated cameras for full face mask/goggles for use in commercial aviation. Further research and development would provide a useful alternative to the problem of viewing instruments in a smoke filled cockpit.

## 1.17 Organisational and Management Information

---

### 1.17.1 Company Overview

United Parcel Service (UPS) corporate headquarters are located in Atlanta, Georgia, and its flight operations are based in Louisville, Kentucky. UPS employs 408,00 worldwide, (340,000 U.S., 68,000 international), and, according to its February 2010 Securities Exchange Commission 10K filing, employs about 2800 pilots who are represented by the Independent Pilots Association. The company most recently earned \$49.6 billion in revenue for the year 2010.

UPS operated 218 aircraft from the following air hubs:

United States:

- › Louisville, Kentucky (Main US Air Hub)
- › Philadelphia, Pennsylvania
- › Ontario, California
- › Rockford, Illinois
- › Anchorage, Alaska

Europe:

- › Cologne/Bonn, Germany

Asia Pacific:

- › Shanghai; Shenzhen; Hong Kong

Latin America and Caribbean:

- › Miami, Florida., USA

According to UPS, the company operated 942 domestic flight segments, and 815 international flight segments. The sole UPS flight crew base for the B747-400 was located in Anchorage, Alaska (ANC). Both accident flight crewmembers were based in ANC.

## 1.18 Additional Information

---

### 1.18.1 Guidance Documentation for Lithium Battery Carriage

#### Transportation Regulations for Lithium, Lithium-Ion and Lithium-Ion Polymer Cells and Batteries

The regulations that govern the transport of primary lithium (metal) and rechargeable lithium-ion (including lithium-ion polymer) cells and batteries include the International Civil Aviation Organization (ICAO) Technical Instructions and corresponding International Air Transport Association (IATA) Dangerous Goods Regulations, and the International Maritime Dangerous Goods (IMDG) Code.

In addition, lithium and lithium-ion cells and batteries are regulated in the U.S. in accordance with Part 49 of the Code of Federal Regulations, (49 CFR Sections 100-185) of the U.S. Hazardous Materials Regulations (HMR). Section 173.185 and the Special Provisions contained in Section 172.102 provide information on the exceptions and packaging for shipping based on details of weights, tests and classifications. The hazardous materials table in Section 172.101 also provides related shipping information. The Office of Hazardous Materials Safety, which is within the U.S. Department of Transportation's (DOT) Pipeline and Hazardous Materials Safety Administration (PHMSA), is responsible for writing the U.S. regulations that govern the transportation of hazardous materials (also known as dangerous goods) by air, rail, highway and water and drafting the regulations that govern such materials. These regulations are based on the UN Recommendations on the Transport of Dangerous Goods Model Regulations and UN Manual of Tests and Criteria.

#### The UN "T" tests Required By The UN Regulator Scheme

The UN Manual of Tests and Criteria, Fifth Revised Edition (2009), contains the UN T1-T8 Tests that are listed below. These tests only have to be performed once for each cell and battery of a given design, and must be completed prior to shipment. Lithium cells or batteries, which differ from a tested type by:

The following tests must be performed on all primary lithium (metal), rechargeable lithium-ion and lithium-ion polymer cells or batteries.

Test T1: Altitude Simulation - Simulates air transport under low-pressure conditions. Store at 11.6 kPa or less for six (6) hours at 20°C

Test T2: Thermal Test - Assesses cell and battery seal integrity and internal electrical connections using thermal cycling to simulate rapid and extreme temperature changes. Perform ten (10) cycles between 75°C and -40°C, six (6) hours per cycle with no more than 30 minutes between cycles, and then observe for 24 hours.

Test T3: Vibration - Simulates vibration during transport. Sinusoidal waveform with a logarithmic sweep between 7 Hz and 200 Hz and back to 7 Hz in 15 minutes. This cycle must be repeated 12 times for a total of three (3) hours for each of three (3) mutually perpendicular mounting positions of the cell or battery.

Test T4: Shock - Simulates possible impacts during transport. Half-sine shock of peak acceleration of the positive direction and three (3) shocks in the negative direction of three (3) mutually perpendicular mounting positions for a total of 18 shocks.

Test T5: External Short Circuit - Simulated an external short circuit. After stabilizing at 5°C, apply an external resistance of less than 0.1 ohm for one (1) hour and then observe for six (6) hours.

Test T6:Impact - Simulates an impact. Place a 15.8 mm diameter bar across the sample and then drop a 9.1 kg mass from a height of 61 cm on to the bar, and then observe for six (6) hours.

Test T7:Overcharge - Evaluates the ability of a rechargeable battery to withstand overcharge. Charge at twice the manufacturer's recommended maximum continuous charge current for 24 hours, and then observe for seven (7) days.

Test T8:Forced Discharge - Evaluates the ability of a primary or a rechargeable cell to withstand forced discharge. Force discharge at an initial current equal to the maximum

#### IATA Lithium Battery Guidance Document

There are several industry guidance documents available regarding the transport of lithium metal and lithium ion batteries.

Transport of dangerous goods by air by U.S. carriers must be in accordance with United States Regulations 49 CFR Parts 171-180 or the ICAO Technical Instructions as limited by 49 CFR Part 171 Subpart C.

This document is based on the provisions set out in the 2013-2014 Edition of the ICAO Technical Instruction for the Safe Transport of Dangerous Goods by Air and the 54th Edition of the IATA Dangerous Goods Regulations (DGR).

The purpose of this document is to provide guidance for complying with provisions applicable to the transport by air of lithium batteries as set out in the DGR.

#### IATA Dangerous Goods Regulations

PACKING INSTRUCTION 965 – 970: This instruction applies to lithium ion or lithium polymer cells and batteries (UN 3480) on passenger and cargo aircraft only

#### EASA

EU Commission Regulation 965/2012 contains provisions for the safe transport of dangerous goods and states in part CAT (Commercial Air Transport Operations) that the transport of DGs by air shall be conducted in accordance with Annex 18 to the Chicago Convention as last amended and amplified by the 'Technical instructions for the safe transport of dangerous goods by air' (ICAO Doc 9284-AN/905), including its supplements and any other addenda or corrigenda, it is via this dynamic reference that EASA make the provisions of the Instructions binding in Europe.



### 1.18.2 Smoke in the Cockpit - Characterising the Problem

Smoke as a factor in emergency situations is a quantitative problem based on density, volume and flow rate. What defines smoke and fumes as an obstruction to normal operation in a cockpit can be a subjective, other than the fact that smoke is indicative or either a symptom of another failure, usually electrical or there is a cargo fire.

In this accident, the smoke was continuous and of sufficient density and rate of flow to prevent viewing the flight displays, radios panels and the view outside the cockpit.

As an indication of the smoke in the cockpit problem, the pictures below are of an FAA test of an EFB1/Laptop battery fire. The test is a good indication of the lack of visibility encountered when a cockpit is full or filling with smoke.<sup>59</sup>

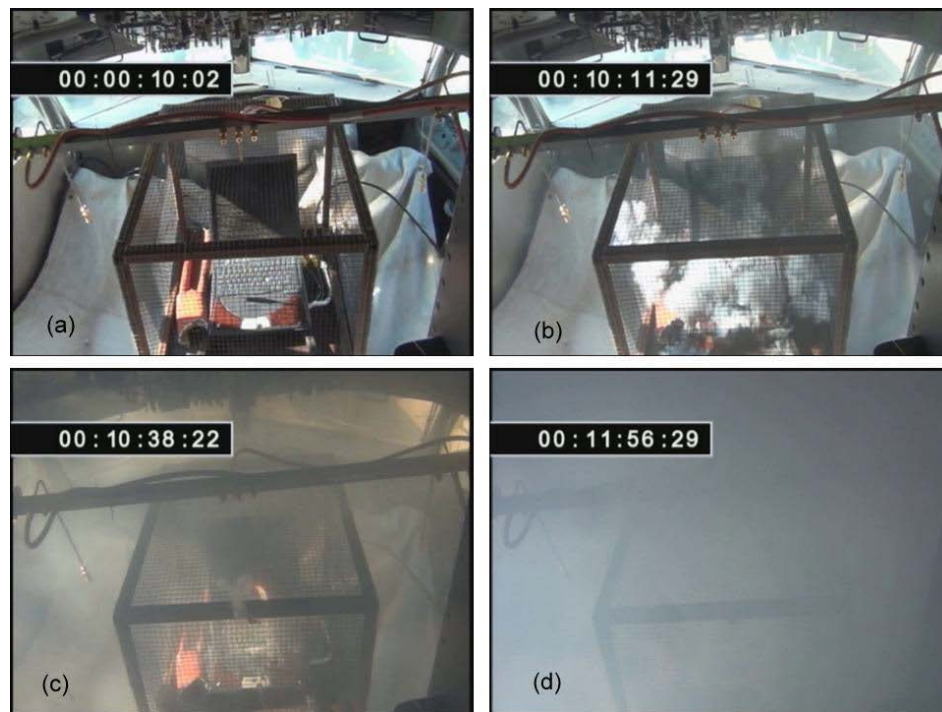

Picture 5 - Loss of pilot vision - ensuring pilot vision in the presences of continuous smoke.

The visibility should be sufficient to view the attitude indicator or primary flight display and to see outside the aircraft for landing. In addition, it is imperative that the crew be able to view the instruments to navigate and they must be able see to program the flight management computer and the audio control panels.

The checklist must be visible so that procedures can be followed to prepare for landing and manage the smoke/fire/fumes problem. Adequate visibility on the flight deck should be maintained during a smoke/fire/fume event.

<sup>59</sup> This test was not connected to this accident investigation. This was an Electronic Flight Bag (EFB) Hazard Assessment. The Laptop was outfitted with a high capacity (7.2 Ah), 9 cell Li-Ion battery . The battery has been modified to initiate thermal runaway, and the laptop placed in a Boeing 737 cockpit.

## Smoke Generation by a Continuous Source Involving Smoke Cockpit Penetration with no Method of Fire Suppression or Smoke Clearance

Smoke migration is a result of a spreading fire. As a fire burns, heat is created and the products of combustion begin to migrate. Minimising the spreading of smoke and fumes into the flight deck is critical for continued safe operation of the aircraft.

Smoke is a factor in the inability to view the instruments. The composition of the smoke based on the residue found at the accident site was the result of black smoke, typically containing carbonized particles. The Pyrolysis of the burning material, especially incomplete combustion or smouldering without adequate oxygen supply, also results in production of a large amount of hydrocarbons. Heavier hydrocarbons may condense as tar; smoke with significant tar content is yellow to brown.

In addition to the above, the following conditions are considered unsafe:

There is a deficiency in certain components which are involved in fire protection or which are intended to minimise, retard the effects of fire, smoke in a survivable crash, preventing them to perform their intended function; for instance, deficiency in cargo liners or cabin material leading to non-compliance with the applicable flammability requirements.

### 1.18.3 Single Point of Failure [SPoF] Analysis

The failure mode concept of the Single Point of Failure [SPoF] is a general causal theory that determines that a single failure of a system, structural component or human interface could be the initiating point for subsequent multiple failures.

As these failures of systems can create an unsafe condition, which reduces the capability of the aircraft or reduces the ability of the crew to cope with adverse operating conditions, the determination of the origin of the SPoF is important to determine and develop a safety case.

Typically these failures bypass normal redundancies and failure gates which by their nature make prediction for multiple cascading failure scenarios problematic. In the case of this accident it was relatively straight forward to establish the cause of the failures - a catastrophic main deck cargo fire on the main cargo deck auto- ignited, remained in a sustained state of combustion, resulting in the damage to the fire protections and critical systems leading eventually to the loss of the aircraft and crew.

What affect the fire had on the cargo compartment liner can be determined by the cascading failures recorded in the various digital recording devices on-board the aircraft and from the ATC communications.

Generalised single point failures where physical evidence is not available in sufficient quantities to develop a causal theory can be modelled based on the accident digital data and derived analysis as evidence. These are typically the accident report findings, although extraneous variables relative to a unique group of data can be employed to support the logical sequencing where assumptions as to cause and effect have to be employed in the causal hypothesis - the ACARS/AHM data in this particular accident case.

Single point of failure theory in this accident provides a logical analysis to determine the point of origin for the single failure case where all of the protections have been compromised: this is referred to as the Initiating Action [IA].

The Initiating Action leading to cascading failures is the point where the airworthiness is compromised to the extent that the outcome of an event can move from possible or probable to improbable/impossible<sup>60</sup>.

In the case of this accident, the single point of failure is based on a structural limitation inherent in the cargo compartment liners residual mechanical load bearing and damage tolerance when exposed to sustained thermal loading over a long duration in conjunction with vibration, acoustic, mechanical and ballistic interference.

Further analysis concerns the question of why the fire was not contained by the cargo compartment liners and what was the effect on the aircraft when the cargo compartment liners failed as a barrier.

#### 1.18.4 Modelling of Single Point Failures

Single point failure in this accident was the inability of the cargo compartment liner to prevent the fire and smoke penetration of the area above pallet locations in main deck fire zone 3.

##### Cascading Failures

While similar to multiple failures, cascading failures are a specific type of multiple failures. The failure of a system due to the failure of another is known as cascading due to the effect to the pilots as the failures occur in a rapid sequence.

As the cargo compartment liner failed, the thermal energy available was immediately affecting the systems above the fire location – this included the control assembly trusses, the oxygen system, the ECS ducting and the habitable area above the fire in the supernumerary compartment and the cockpit.

##### Cargo Onboard

The Cargo Group obtained package details for shipments contained in all positions of the aircraft.

The group reviewed the package details and collaboratively identified any shipments that had generic shipment descriptions or appeared to contain items that could potentially be hazardous. The group identified many shipments of lithium batteries and electronic equipment that contained or were packed with this equipment. The remainder of the items were identified as general freight, consisting largely of clothes, shoes, books, toys, lighting, transformers, solenoids, USB drives, circuitry, etc.

The cargo factual report is attached in Appendix A.

##### Fire Protection

The cargo compartment liner's function is to contain a fire within the cargo hold, while simultaneously preventing the penetration of smoke or fumes into occupied areas and providing fire protection to critical systems. In the accident, the cargo compartment liner<sup>61</sup> failed as an effective barrier.

As the cargo liner is the certification standard barrier to prevent fire, smoke, fumes or from entering the occupied zones and for the protection of critical systems the single point of failure model was used to map the Initiating Action and cascading failures.

---

<sup>60</sup> The definition of 'possible or probable' assumes the aircraft can be managed to the ground and the crew have a reasonable possibility of survivable.

<sup>61</sup> The certification standards and compliance information can be located at <http://www.ecfr.gov>

### 1.18.5 Cargo Compartment Classification Revision Following Cargo Compartment Fire Events

#### Background<sup>62</sup>

Following an accident investigation of a South African Airways Boeing 747 Combi aeroplane lost in the Indian Ocean in 1987 with 159 fatalities the US National Transportation Safety Board (NTSB) issued recommendations to revise the Class B cargo compartments standards. This was based on the report from the South African Board of Inquiry mentioning that a fire broke out in the Class B cargo compartment on the main deck, which could not be extinguished. An Airworthiness Directive (FAA AD 93-07-155 ) was issued by the US Federal Aviation Administration (hereinafter FAA) requiring changes to Class B cargo compartments on the main deck of large transport aeroplanes. Similar requirements were addressed in Europe (e.g. in France and some other JAA countries) for large Combi aeroplanes. Tests were performed by the FAA to investigate the efficacy of the Class B concept for smaller sized compartments, such as those installed in commuter aeroplanes. It was found that the maximum compartment size for which successful fire fighting could be imagined was much less than previously thought.

Further, the FAA tasked the Aviation Rulemaking Advisory Committee (hereinafter ARAC) to develop a proposal for future Class B cargo compartments. A Cargo Standards Harmonisation Working Group was formed including members from the FAA, Joint Aviation Authorities (hereinafter JAA), aircraft manufacturers and operators, which developed a draft status requirements and guidance (a draft Notice of Proposed Rulemaking (NPRM)) and a draft Advisory Circular (AC)) for a new Class B cargo compartment definition as well as design criteria for a new Class F cargo compartment type. This latter class of compartment was introduced because whilst it was concluded that manual fire fighting was not feasible for larger compartments, alternatives other than just the existing Class C were identified.

The manufacturer recognised that Class E cargo compartments are not required to have active fire suppression installed.

*Text:*

*Boeing Protection of Critical Systems*

*Protection of Critical Systems and Equipment within Class E Cargo Compartments*

*Oct 14, 1993*

*A specific requirement to protect critical systems and equipment in Class E cargo compartments from fire damage does not exist.*

*A Boeing model 747-200 'Combi' aircraft developed a major fire in the main deck Class B cargo compartment, causing significant systems and structural damage, which may have contributed to the loss of the aircraft. Both Class B and Class E cargo compartments are similar in that they do not have active fire suppression systems.*

*On Class E cargo compartments, the fire is controlled by shutting off ventilating airflow. In Class E cargo compartments, fire can quickly reach dangerous proportions because no fast acting active fire suppression system is installed. In a Class E compartment, an uncontrolled fire could damage critical systems and equipment to compromise flight safety before ventilating airflow could be effectively shut off. For this reason, protection of these critical systems must be ensured.*

---

<sup>62</sup> Refer to EASA NOTICE OF PROPOSED AMENDMENT (NPA) # 2008-10

The manufacture closed this FAA requirement through the application of CFR14 that relates to the current certification standards for cargo compartment liners.<sup>63</sup>

In March 2006 EASA set up a Rulemaking Group (hereinafter referred to as the “Group”) to accomplish the rulemaking task 25.041. The Group was composed of cabin safety experts, members of the JAA Cabin Safety Steering Group (CSSG), nominated by National Aviation Authorities, aircraft manufacturers and operators as well as of observers from the FAA and Transport Canada. The Group started to work on this subject in accordance with the Terms of Reference (TOR) 25.041. The task was to review the work done and the documents prepared by the ARAC Cargo Standards HWG for the FAA, conduct a Regulatory Impact Assessment (RIA) and when justified by RIA to develop a revised Class B cargo compartment standard as well as a new Class F cargo compartment standard to be proposed for inclusion in CS-25.

Class F Cargo Compartments. A Class F cargo or baggage compartment is one in which:

The Class F cargo compartment would not be limited in size but would require a means to control the fire without requiring a crewmember to enter the compartment.

- (1) There is a separate approved smoke detector or fire detector system to give warning at the pilot or flight engineer station;
- (2) There are means to extinguish or control a fire without requiring a crewmember to enter the compartment; and
- (3) There are means to exclude hazardous quantities of smoke, flames

The introduction of Class F cargo compartments required the following regulatory action:

- to introduce the compartment type and require a fire/smoke detection system, a means to extinguish or control a fire without requiring a crew member to enter a compartment and means to exclude hazardous quantities of smoke, flames or extinguishing agent from any occupied compartment.
- to add the new compartment type to the liner requirements
- to add the new compartment type to the floor panel requirements to meet the same standard as Class B, C and E

The requirements for new Class F compartments would allow flexibility in new aeroplane designs while ensuring that adequate fire control can be obtained. The objective nature of the requirement is such that it is unlikely that further regulatory change would be required as a result of emerging technologies.

Based on the current fire risk, implementation of a modified Class E compartment for existing aircraft, through an approved STC is viable, if recommended or mandated by the regulatory bodies involved.

#### 1.18.6 Class F Cargo Compartment – Modification of Existing Standards

In November 1987, a South African Airways Boeing 747 Combi crashed into the Indian Ocean off the coast of Mauritius with the loss of 159 lives. The South African Board of Inquiry determined that a major fire had developed in the main deck (Class B) cargo compartment.

The limitations of class E Cargo compartment fire suppression are recognised where the mitigation strategy is reducing ventilating flow and depressurising the cargo deck.

---

<sup>63</sup> The liner and floor materials in the cargo compartments comply with the test requirements specified in 14 Code of Federal Regulations 46 and Issue Paper SE-1 “Protection of Critical Systems and Equipment within Class E Cargo Compartments.”

A study by the FAA indicated that it was unrealistic to expect crewmembers to enter the cargo compartment when fire was present in an attempt to extinguish the fire. Longer routes, combined with the seat of the fire being inaccessible may allow fires to develop to the level of severity that would damage the liner and subsequently the aeroplane structure or systems.

Class F cargo compartment would not be limited in size but would require a means to control the fire without requiring a crewmember to enter the compartment

#### 1.18.7 ICAO Annex 08 - Airworthiness of Aircraft

##### Chapter 4 Annex 8 — Airworthiness of Aircraft

In ICAO Annex 8 – Airworthiness Standards and Recommended Practices, upper level requirements.

Annex 8, IIB-4-3 18/11/10

g) *Cargo compartment protection.*

- 1) Each cargo compartment accessible to a crew member in a passenger-carrying aeroplane shall be equipped with a fire suppression system;
- 2) each cargo compartment not accessible to a crew member shall be equipped with a built-in fire detection system and a built-in fire suppression system; and
- 3) cargo compartment fire suppression systems, including their extinguishing agents, shall be designed so as to take into account a sudden and extensive fire such as could be caused by an explosive or incendiary device or dangerous goods.

h) *Incapacitation of occupants.*

- 1) For aeroplanes for which application for certification was submitted on or after 24 February 2013, design precautions shall be taken to protect against possible instances of cabin depressurization and against the presence of smoke or other toxic gases that could incapacitate the occupants of the aeroplane.
- 2) In addition, for aeroplanes of a maximum certificated take-off mass in excess of 45 500 kg or with a passenger seating capacity greater than 60, design precautions shall be taken to protect against possible instances of cabin depressurization and against the presence of smoke or other toxic gases caused by explosive or incendiary devices or dangerous goods, which could incapacitate the occupants of the aeroplane.

i) *Protection of the flight crew compartment from smoke and fumes.*

- 1) For aeroplanes of a maximum certificated take-off mass in excess of 45 500 kg or with a passenger seating capacity greater than 60, means shall be provided to minimize entry into the flight crew compartment of smoke, fumes and noxious vapours generated by an explosion or fire on the aeroplane.

#### 1.18.8 Cargo Containers and Pallets

The selection of materials used in the construction of cargo containers is only subject to a horizontal Bunsen burner test, which does not prevent the use of highly combustible materials. The current certification standard requires exposure to flame to determine the fire resistant properties.

Additionally, the effect of the use of containers and pallets to contain cargo is not factored into the current overall fire protection strategy or certification process.

The contribution to the total fire load if the cargo container or pallet ignites is not factored into the total fire risk.

### 1.18.9 Fire Suppression

The fire suppression strategy in class E main deck cargo compartments is based on controlling the airflow, oxygen deprivation and fire resistant materials.

Main deck cargo compartment of a Boeing 747-4AF is large, 26,000 cu ft (736 cu m), the cargo hold is an open architecture type without compartmentalisation barriers to prevent the transmission of a fire or smoke.

Large fires can develop before any passive suppression due to oxygen deprivation can slow down conventional cargo fires<sup>64</sup>.

On Class E cargo compartments, the fire is controlled by shutting off ventilating airflow. In Class E cargo compartments, fire can rapidly escalate to dangerous proportions because no fast acting active fire suppression system is required to be installed.

Depressurization and air flow venting of the Class E compartment was the fire suppression option available to the crew of this accident.

#### The Fire Triangle/ Tetrahedron

The fire suppression methodology is predicated on the conventional fire triangle as a method of controlling the chemical process of combustion.

The fire triangle or combustion triangle illustrates the three elements required for a conventional fire ignition and sustain a conventional fire.

The fire tetrahedron represents the addition of a component, the chemical chain reaction, to the three already present in the fire triangle. Once a fire has started, the resulting exothermic chain reaction sustains the fire and allows it to continue until or unless at least one of the elements of the fire is blocked.

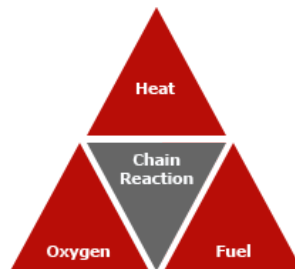

Figure 35 Fire Tetrahedron

The requirements for Class E cargo fire suppression are defined in 14 CFR 25.857(e) as follows:

e) Class E. A Class E cargo compartment is one on aircraft used only for the carriage of cargo and in which—

- There is a separate approved smoke or fire detector system to give warning at the pilot or flight engineer station;

---

<sup>64</sup> Conventional fires in this context are based around the requirements for ignition and combustion found in the standard fire triangle: Oxygen/Heat/Fuel

- There are means to shut off the ventilating airflow to, or within, the compartment, and the controls for these means are accessible to the flight crew in the crew compartment;
- There are means to exclude hazardous quantities of smoke, flames, or noxious gases, from the flight crew compartment; and
- The required crew emergency exits are accessible under any cargo loading condition.

There is no certification requirement for active fire suppression.

#### 1.18.10 Lithium Batteries - Assessing The Risk

Large quantities of lithium metal batteries are a Class D fire/combustible metals risk item covered by dangerous goods regulations relating to transport by air<sup>65</sup>.

Class D fires are a chemical reaction which is self-sustaining. Battery fires are electric fires, to extinguish the fire the short must be removed and the temperature reduced as the short is internal to the cell during a thermal runaway, the thermal runaway has to be stopped to contain the fire hazard. Uncontained, the battery discharge can spread to adjacent cells establishing a chain reaction.

The explosive potential of lithium metal cells can easily damage (and potentially perforate) cargo liners, or activate the pressure relief panels in a cargo compartment. Either of these circumstances can potentially lead to a loss of Halon 1301 [in class C cargo compartments], allowing rapid fire spread within a cargo compartment to other flammable materials. For this reason, lithium metal cells are currently prohibited as bulk cargo shipments on passenger carrying aircraft.<sup>66</sup>

Lithium batteries are currently classified as Class 9 materials under the Hazardous Materials Regulations (HMR) (49 CFR 180 185). Nonetheless, most small lithium batteries and devices are currently exempted from the Class 9 provisions of the HMR. Because of this exception, they do not require a Notice to the Pilot in Command (NOTOC) to alert the crew of their presence on-board an aircraft.

Lithium-ion (Li-ion) has become the dominant rechargeable battery chemistry for consumer electronics devices and is poised to become commonplace for industrial, transportation, and power-storage applications. From a safety and fire protection standpoint, a high energy density coupled with a flammable organic, rather than aqueous, electrolyte has created a number of new challenges with regard to the design of batteries containing lithium-ion cells, and with regard to the storage and handling of these batteries.

The organic electrolytes is composed of a volatile and flammable chemicals which in an inert state are not considered hazardous; but if damaged, subjected to water ingress or to increased energy levels from an external source, either thermal, acoustic or mechanical can be considered hazardous.

Lithium ion batteries are highly flammable when agitated, which can lead to an exothermic<sup>67</sup> reaction which in the context of this investigation is referred to as 'thermal runaway'.

FAA testing and research indicates<sup>68</sup> that a single cell in thermal runaway has a thermodynamic effect on adjacent cells in a bulk shipment cardboard box. It has been determined that a single cell in thermal runaway produces enough heat to cause other nearby cells within the shipping box to also go into thermal runaway. This process has been shown to propagate to all cells within the box as well as to

---

<sup>65</sup> See SAFO 09013

<sup>66</sup> SAFO 10017 - Risks in Transporting Lithium Batteries in Cargo by Aircraft

<sup>67</sup> An exothermic reaction is a chemical or physical reaction that where the product is heat

<sup>68</sup> NTSB Materials Laboratory Study Report No. 12-019



adjacent boxes of cells, as shown in a test with three 100 cell boxes. Halon 1301, the fire suppressant used in class C aircraft cargo compartments is ineffective in stopping the propagation of thermal runaway in lithium-ion and metal cells, though it does suppress the open flame from a lithium ion battery and will spread to other combustibles. It is ineffective against a flaming lithium metal battery.

This research has been the basis for banning the bulk shipment of lithium metal batteries as cargo on-board passenger carrying aircraft.

#### 1.18.11 Lithium Ion Batteries – Description[Typical]

The term lithium-ion battery refers to a battery where the negative electrode (anode) and positive electrode (cathode) materials serve as a host for the lithium ion (Li+). Lithium ions move from the anode to the cathode during discharge and are intercalated into (inserted into voids in the crystallographic structure of) the cathode. The ions reverse direction during charging.

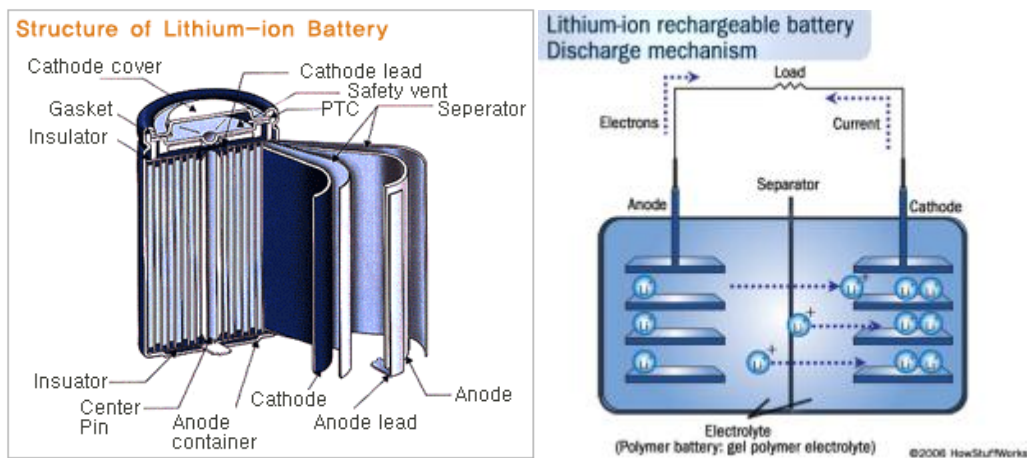

Figure 36 Battery Structure/Discharge Mechanism

#### Description

In a lithium-ion cell, the four primary functional components of a practical lithium-ion cell are the negative electrode (anode), positive electrode (cathode), separator, and electrolyte. Alternating layers of anode and cathode are separated by a porous film (separator). An electrolyte composed of an organic solvent and dissolved lithium salt provides the media for lithium ion transport.

The diagram above shows a cylindrical cell. These are the most common consumer electronics lithium-ion cell.

The electrolyte in a lithium-ion cell is typically a mixture of organic carbonates such as ethylene carbonate or diethyl carbonate.

The UN Recommendations on the Transport of Dangerous Goods, Model Regulations, and Manual of Tests and Criteria are primarily designed to ensure the safety of lithium-ion cells, battery packs, and batteries contained in, or packed with, equipment during transport. These regulations specify that in order to be shipped, lithium-ion cells or batteries must be able to pass a series of tests that have been selected to simulate extreme conditions that cargo may encounter.

The UN Model Regulations and UN Tests have been developed by a UN subcommittee comprised of representatives from various nations. A number of regulatory bodies that reference or have adopted the UN tests include:

- United States Department of Transportation (DOT), in the Code of Federal Regulations (CFR) Title 49
- The International Air Transport Association (IATA), in the Dangerous Goods Regulations
- The International Civil Aviation Association (ICAO), in the Technical Instructions for the Safe Transport of Dangerous Goods

Specific packaging requirements for shipment should include the following:

- Requiring that cells or batteries be separated to prevent short circuits
- Requiring “strong outer packaging” or UN specification packaging
- Limits on the numbers of cells or batteries placed in a single package
- Specific labels for outer packages
- Hazardous material shipping training for employees engaged in packaging cells or batteries for transport

Lithium-ion battery reliability and safety is generally considered a function of the entirety of the cell, pack, system design, and manufacture, dependent on a robust quality process and benchmarked to international standards.

#### 1.18.12 Cell and Battery Failure Modes

##### Non-Energetic Failures

Lithium-ion batteries can fail in both non-energetic and energetic modes. Typical non-energetic failure modes (usually considered benign failures) do not lead to thermal runaway.

##### Energetic Failures: Thermal Runaway

Cell thermal runaway refers to rapid self-heating of a cell derived from the exothermic chemical reaction of the highly oxidizing positive electrode and the highly reducing negative electrode. This can occur with batteries of almost any chemistry.

In a thermal runaway reaction, a cell rapidly releases its stored energy. The more energy a cell has stored, the more energetic a thermal runaway reaction will be. One of the reasons lithium-ion cell thermal runaway reactions can be very energetic as these cells have very high-energy densities compared to other cell chemistries.

An additional factor determining why lithium-ion cell thermal runaway reactions can be very energetic is because these cells contain flammable electrolyte, consequently, not only do they store electrical energy in the form of chemical potential energy, they store appreciable chemical energy in the form of combustible materials.

The likelihood of initiating cell thermal runaway is analogous to the likelihood of ignition of many typical combustion reactions: for initiation of cell thermal runaway the rate of heat generation must exceed the rate of heat loss. As discussed above, self-heating of the most severe thermal runaway reaction will be achieved when that cell is at 100% SOC<sup>69</sup>, or is overcharged, because the cell will contain maximum electrical energy. If a typical fully charged (or overcharged), lithiumion cell undergoes a thermal runaway reaction a number of things occur.

- Cell internal temperature increases.
- Cell internal pressure increases.
- Cell undergoes venting.

---

<sup>69</sup> State-Of-Charge

- Cell contents may be ejected.
- Cell thermal runaway may propagate to adjacent cells.

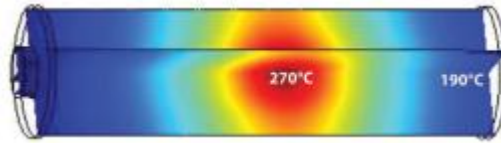

Figure 37 - Typical Thermal Runaway Temperatures [cell type battery]

Typical internal temperature distribution and negative electrode reacted ratio distribution at thermal runaway. The central portion of the battery indicates a typical temperature distribution.

Root cause analysis of energetic cell thermal runaway and battery failures can be classified into the following classifications:

- Thermal abuse
- Mechanical abuse
- Electrical abuse
- Poor cell electrochemical design
- Internal cell faults associated with cell manufacturing defects

When the material is exposed to forms of energy, such as thermal or mechanical energy, it can reach an onset temperature that begins to self-heat and progresses into thermal runaway.

#### 1.18.13 Smoke in the cockpit

Smoke in the cockpit under the current certification standards is predicated around the assumption that smoke in the cockpit is temporary. The Non Normal Check lists for SFF events are based around presumptions on the emergency scenarios considered relevant. An emergency scenario, uncontained, can escalate rapidly to an abnormal situation where the assumed safety gates are no longer valid.

The FAA attempted to address the loss of pilot vision by requiring the one-time reduction of a small amount of temporary smoke; there is no certification standard for ensuring pilot vision in the presence of continuous smoke. The current requirement is that smoke should be reduced within three minutes such that any residual smoke (haze) does not distract the flight crew nor interfere with operations under Instrument Flight Rules (IFR) or Visual Flight Rules (VFR).

The single significant safety factor with smoke in the cockpit is the ability of the crew to safely operate the aircraft. This should not be impaired by loss of vision due to smoke from a continuous source in or contiguous with the cockpit.

#### 1.18.14 Heat and Combustion By-products

The engineering, materials and the composition of materials used in today's aircraft have a large degree of safety built in. However, regardless of the safety devices/functions designed and built in, when any material or chemical is heated, it will reach a flash or combustion point, at which point, an open flame is produced which can easily spread and likely will produce smoke. Often, prior to developing an open flame, overheated materials or components will also create smoke or fumes which can travel to the cockpit and/or cabin via the environmental control system, or as in this accident, directly through a damaged cargo compartment liner.

#### 1.18.15 Controlling Smoke Penetration

Boeing uses a two-step approach to exclude hazardous quantities of smoke and noxious gases from entering the flight deck or other occupied compartments.

- 1) The flight deck and supernumerary compartments are maintained at a higher pressure relative to adjacent compartments that may contain smoke or noxious gases during Class C or E fire suppression mode.
- 2) Airflow is reduced and the cabin depressurised.

#### 1.18.16 B747 Cargo Fire Related Accidents

B747 Fire on board investigations include South African Airways and Korean B747 accidents which have several factual similarities to this particular investigation

##### Asiana Flight 991

The last hull loss<sup>70</sup> due to an on-board fire was a B747-4 Freighter was Asiana Flight 991 which departed Incheon International Airport at 16:47 UTC on 27 July 2011, or 02:47 AM on 28 July 2011 local time, bound for Shanghai Pudong International Airport.

At 04:03 [Local], the crew reported a fire and diverted to Jeju Airport for an emergency landing. Radio contact was lost with the aircraft at 4:11AM when the aircraft crashed 107 kilometers southwest off Jeju Island.

The aircraft that was involved in the accident was a Boeing 747-400F, registered HL7604, which was built in 2006. The aircraft had clocked 26,300 flight hours and was powered by four General Electric CF6-80C2 engines.

The crew of Asiana Flight 991 reported smoke and aircraft control problems prior to the loss of radar contact.

The onset of the emergency, the sequencing, control anomalies reported and subsequent uncontrolled descent into the sea occur in a similar time frame to this accident.

The captain replied to KAL886's question about the control problems, "Rudder control... flight control, all are not working. The aircraft was observed to climbing and descending characterised by phugoid oscillations, these are typically ~ 20 sec per cycle, before the aft section separated and fell into the sea. Two radar traces were detected.

The crew attempted a diversion to an alternate aerodrome before communication was lost and the aircraft disintegrated in mid-air.

Tertiary analysis of the recovered components, in particular the smoke vent and residue, indicates that there is similar evidence for the smoke profile and residue markings characterised by a large, uncontained cargo fire..

##### South African Airways Flight 295

A Boeing 747-244B Combi, registration ZS-SAS (serial number 22171) that was delivered to the airline in 1980. The aircraft took off on 27 November 1987 from Taipei Chiang Kai Shek International Airport, on a flight to Johannesburg via Mauritius. At some point during the flight, a fire developed in the cargo

---

<sup>70</sup> As of the first quarter 2013

section on the main deck. The origin of the fire was not determined, the aircraft made an uncontrolled descent into the sea.

During the investigation the investigators questioned if the fire had breached the crown of the fuselage. The investigation was indeterminate on this aspect.

#### 1.18.17 Cargo Compartment Acoustic/Vibration Mapping – Structural Acoustic Coupling in Aircraft Fuselages

The investigation concentrated on the cargo fire casual factors, the root cause analysis of the battery active failures while quantifying the thermal loads and peak release temperatures of the batteries, the palletized cargo and containers. What the investigation could not determine was the initiating action that resulted in the cargo fire ignition.

One line of testing outside the scope of this investigation was the investigation of the possible effect of structural-acoustic coupling to determine the acoustic principle sources and transmission paths for airframe junction vibration transmission, the effect of multi-frequency phased vibration of the fuselage structure caused by tonal disturbances, either engine derived or by airbourne structural excitations, affecting the modal characteristics and fuselage dynamic responses.

Structural-acoustic coupling phenomenon in an aircraft fuselage is a known characteristic of aeroelastic structures. The structural and acoustic modes can be derived for vibration analysis using a Finite Element Model [FEM].

Currently there are no requirements to model structural acoustic coupling induced vibration of the interior of the large aircraft freight compartments to detect if mechanical energy transmitted through acoustics, vibration or coupled, may contribute to any of the recognised forms of coupled structural vibrations that can occur in large aeroelastic structures.

These aeroelastic phenomena have been demonstrated to produce resonance/vibration during certain flight phases in large aircraft. Structural and acoustic analysis can determine possible occurrences of structural-acoustic coupling in the fuselage structure during predetermined phases of flight, for example at high take off weights, high power settings and in a cruise/climb configuration.

There is currently no requirement for information on the modal characteristics, fuselage response and structural-acoustic coupling of cargo compartments and this information is not a direct factor for the limitations governing the carriage of hazardous materials, however, there are clearly defined test criteria for damage tolerance in UN Manual of Tests and Criteria, Test 3 – Vibration<sup>71</sup>.

In addition this consistent level of vibration in specific flight phases could be in excess of the requirements in the UN Manual of Tests and Criteria, Test 3 – Vibration.

Further investigation could be performed by the ICAO, the regulators and manufacturers to investigate the vibration and acoustic signatures of large cargo areas for structural-acoustic vibration, possibly in a harmonic form, resulting from the combination of engine and fuselage vibration.

It was not possible within the remit of the investigation to test Class E cargo compartments and the vibration response and interior acoustic fields. Structural and acoustic analysis can determine possible occurrences of structural-acoustic coupling in the fuselage structure during predetermined phases of

---

<sup>71</sup> UN Manual of Tests and Criteria, Test 3 – Vibration. Document Reference ST-SG-AC10-11-Rev5. Among the new amendments are revised provisions for the testing and classification of lithium metal and lithium ion batteries[sub section 38.3

flight, the significant vibro-acoustic signatures and can be used to determine the principles sources and transmitting paths of the vibration.

Given the active failure modes of lithium batteries, the battery risk factors concerning possible susceptibility to various extraneous forms of mechanical energy - for example vibration - structural-acoustic couples or combinations of various acoustic and structural vibrations could be further analysed and a safety case developed in conjunction with the UN, ICAO and industry working groups.

## 1.19. Useful or Effective Investigation Techniques

---

### 1.19.1. Airbus A330 Synthetic Training Device, Abu Dhabi, UAE: Smoke/Fire/Fumes Vision Assistance Testing<sup>72</sup>

Additional crew performance and CRM analysis was performed in a Smoke, Fire, Fumes [SFF] environment to further analyse crew vital actions in a continuous and completely smoke filled cockpit environment where a crew has access to vision enhancement equipment supplied by a manufacturer<sup>73</sup>.

The testing used type specific line captains from a local airline with no prior experience of either completely smoked filled cockpits or the vision assistance.

Crew interaction, the vision assistance system operation, task management, crew coordination and critical decision making in complex high task orientated environments that are not routinely included in normal emergency training were observed with crew based recommendations noted regarding CRM and task prioritisation.

A full description of this testing is included in the Appendix G.

### 1.19.2. NTSB CVR Sound Spectrum Analysis

Due to the fire, both the in-flight fire and the post-accident fire, it was not possible to recover any of the oxygen masks for investigation. No mask components were recovered in a damaged condition for non-volatile investigation.

It was not possible from the DFDR or the AHM/ACAR's messages to determine the oxygen state in the aircraft during the emergency, either the volume available or the rate of supply.

Evidentially, what can be determined is that the Captain's oxygen supply abruptly stops and the Captain leaves the left hand seat to locate the portable oxygen.

Further compounding the oxygen loss scenario was the apparent discrepancy with the F.O.'s oxygen supply, which was faltering, but not resulting in a complete cessation of the oxygen supply.

During the initial stages of the investigation, the focus was on the functioning of the mask, as through a process of elimination, the factual evidential information was contradicted by the apparent loss of oxygen on one side of the cockpit on a system which has a common supply. The initial conclusion was that as the masks have a common supply, and one side failed, the component delivery the supplemental oxygen required further investigation.

---

<sup>72</sup> The test report summary is in Section 2. Analysis, of this report

<sup>73</sup> Emergency Vision Assurance System (EVAS) provided the equipment and the smoke generator. The system provides a clear space of air through which a pilot can see flight instruments and out of the front windshield for landing. The pilot still relies on the oxygen mask for breathing, smoke goggles for eye protection and employs approved procedures for clearing smoke from the aircraft.

Prior to an FAA Elevated Mask Test to function check the oxygen system and the oxygen mask at elevated temperatures, the Cockpit Voice Recorder (CVR) Group for this investigation noted that both crewmembers had some unidentified issues with the crew oxygen system.

Both crew had donned their oxygen masks approximately 1.5 minutes after the fire bell sounded. About 5min 30 sec later, the Captain indicated that he was out of oxygen, and his breathing sounds (as captured by the oxygen mask microphone) ceased.

About 2 minutes later, the First Officer's breathing sounds stopped for about 20 seconds. About 20 seconds later the First Officer said "I'm looking for some oxygen" during a radio transmission. Shortly thereafter, his breathing sounds stopped again for about 20 seconds. After this, his breathing sounds can be heard until the end of the recording (about 20 minutes later). However, about 10 minutes before the end of the recording, the First Officer transmitted "...we are running out of oxygen."

In order to better understand how the oxygen system was being used (i.e. the mask configuration of "normal" vs. "100%", the "Emergency" setting, and the smoke vent setting), a flight test was conducted using oxygen masks of the same make/model as was installed on the accident aircraft.

The masks were operated in flight and on the ground, using all possible configuration settings. During these tests, the audio from the mask microphones and the cockpit area microphone was captured by the aircraft's CVR, and used for comparison with the audio from the accident flight.

The audio from the flight test was examined using a software frequency analysis program. Spectrogram charts (three dimensional presentations of time, frequency and energy) of the audio were generated for each of the test segments, and these charts were reviewed for any signatures that were unique to specific settings of the oxygen masks.

Using the empirical data baseline established in the laboratory and through the sound spectrum audio signatures specific to each oxygen mask setting it was possible to conclude that the crew's masks were in different oxygen settings.

This was further validated through the FAA Elevated Mask Testing.

As an alternative investigative method where crew incapacitation is a factor, where there is limited physical evidence which can assist the investigation to narrow down the fields of investigation, if there are possible implications for crew survivability and the airworthiness of the aircraft, this investigative methodology is highly recommended.

#### 1.19.3. Boeing Google Earth Application Combining DFDR Data, ATC Transcripts and Spatial Information

The Manufacturers technical department supplied a version of the Boeing investigation tool based on Google earth.

The software incorporates the DFDR data, ATC and CVR communication, position, aerodrome and associated geographical data. Very useful as an accident oversight tool, particularly where complex lines of information are running concurrently and a clear, accurate casual/incident picture is required for the investigators.

It is a unique and adaptable investigative software tool available to investigators from the manufacturer.

## 2. ANALYSIS

The factual information documented in Section 1 is a comprehensive factual summary of the accident flight, the aircraft and the associated factors that require documentation regarding all factual aspects of the flight.

This section, Section 2, will analyse, as appropriate, the factual information documented in Section 1 which is relevant to the determination the conclusions, causes and contributing factors of this accident

This section will analyse the numerous lines of investigation, from the full scale fire testing through to the operational aspects that were identified during the investigation.

It was found that the extensive damage from the in-flight fire and impact with the ground had either obscured or destroyed the majority of the components. However, through detailed examination, reconstruction and analysis of the recovered components, materials and data derived analysis, potential fire scenarios were developed and where necessary tested.

Information from the evaluation of airflow, material properties, and timing of events led to an understanding of how and where the flammable materials could have ignited and how the fire propagated.

The time interval between take off and the data ending was 51 minutes, the fire bell sounding and the was smoke was detected in the cockpit before the Uncontrolled Flight Into Terrain [UNCIT] was approximately 29 minutes; the time from the fire bell to the Captain oxygen supply stopping abruptly was 5 minutes 30 seconds; the Captain left his seat 8 minutes after the fire bell.

Due to the numerous references to the smoke in the cockpit, emphasis was placed on determining the cues available to the crew, the factors affecting their assessment of the on board situation and the crew survivability.

This section of the report analyses the safety deficiencies regarding materials, safety equipment, crew training and the operator's procedures that were identified during the investigation.

The background to the accident is as follows:

At some point along the flight route, a failure event occurred that provided an ignition source to nearby flammable materials leading to an in-flight fire. The fire spread and increased in intensity rapidly damaging numerous critical systems leading to an unsafe condition and the loss of the aircraft.

The primary factors involved in this occurrence include the following:

- The condition that resulted in the ignition source
- The flammable materials that were available to be ignited, sustain, and propagate the fire
- The location of the fire
- The single point of failure that compromised the critical systems
- The subsequent fire-induced material failures that exacerbated the fire-in-progress
- The lack of detection equipment to enable the crew to accurately assess the source and significance of the initial smoke
- The lack of appropriate in-flight fire fighting measures required to deal successfully with the smoke and fire.
- The decision making in the first stage of the accident event sequence
- The emergency procedures available to the crew
- Alternative vision systems – suitable use of and safety enhancements



Although the data confirms that in-flight fires on-board cargo transport category aircraft under 14 CFR part 121 that result in fatal accidents are rare, many of the same factors listed above were not unique to this aircraft model, airline, or crew.

According to the FAA, 14 CFR part 25 certification, smoke and fume elimination procedures are designed primarily to evacuate the cabin of foreign pollutants. These procedures are not designed to eliminate the cause of the pollutant but rather to increase the aircraft's airflow to evacuate the pollutant. If the cause of the pollutant is a fire and the fire has not been extinguished, it is possible to worsen the situation by increasing airflow through the area where the fire or smouldering condition exists. For this reason, it is important to extinguish the fire<sup>74</sup>

The FAA Advisory Circular [AC] for Large Aircraft: 25-9A, Continuous Smoke in the Cockpit section calls for the conduct of certification tests relating to smoke detection, penetration, and evacuation, and to evaluate related Aircraft Flight Manual (AFM) procedures. The FAR does not require the consideration of continuous smoke generation/evacuation, the FAA recommends that the airframe design address this situation but it is not mandatory.

With no mandatory requirement to assess continuous smoke in the cockpit, collecting test data on the problem followed by deriving a practical mitigation strategy would seem problematic if not mandated by the regulator.

There is no requirement for carriers to have an alternative vision assistance capability. In the case of this accident the inability to view the primary flight displays or radio panels was a causal factor in the event sequence.

---

<sup>74</sup> FAA AC No: 120-80 and CS25-9a

## 2.1 Flight Data Analysis – Flight Profile

---

The following analysis is a factual DFDR report of the accident flight with statements to support the recorded data and associated control anomalies<sup>75</sup>.

CVR excerpts are provided to provide an understanding of the crew response and the operating environment.

### **Data Information Summary:**

The DFDR data showed the aircraft performing a normal take-off and climb.

Prior to reaching cruise altitude, aircraft systems warned the flight crew of a main deck cargo fire.

The flight crew initiated descent and elected to make an emergency return to Dubai International Airport (DXB).

During descent the flight crew experienced a decrease of manual elevator and rudder control.

The decrease of manual elevator and rudder control is consistent with a loss in column and pedal cable tension, respectively.

The autopilot (AP) does not rely on these cable systems and functioned while engaged for the duration of the flight.

The following analysis and event timeline has been created using DFDR data, Air Traffic Control (ATC) transmissions and excerpts from the Cockpit Voice Recorder (CVR).

The following description is a subset of events that occurred in chronological order.

The number is the approximate elapsed time, in UTC, from the engine start.

The following text describes the event.

- ATC: Air Traffic Control transmission
- CAPT: Comment on the CVR by the captain
- F.O: Comment on the CVR by the First Officer/Co-pilot
- PF: Pilot Flying (i.e. the handling pilot)
- CVR: Cockpit Voice Recorder
- GPWS: Ground Proximity Warning System aural alert recorded on CVR
- *Events in italics describe a discrete change*<sup>76</sup>

Following the event description there may be additional text providing additional details

Example:15:16:47 CAPT - Comment about no pitch control

- CAPT: Fire Main Deck
  - 15:16:57 - *Fire Zone 2 Aft Cargo (lower deck)*

---

<sup>75</sup> Refer to Boeing DFDR Analysis– 747-400F in the Section 2.2

<sup>76</sup> An electronic signal referring to a wired signal (not an ARINC signal), for example parameters going into the System Data Acquisition Concentrators

Take Off

The DFDR data show that aircraft performed a normal take off at time 14:50:53 UTC.

Climb out/Climb to cruising level or altitude/Pack 1 ON-OFF-ON.

Pack 1 discrete indicated OFF at time 14:58:30. Pack 1 was reset and discrete indicated ON at time 15:00:18.

- o 14:59:23|CVR|HOT-1: I'm gonna look at pack one.
- o 14:59:56|CVR|HOT-1: trim air's on.
- o 15:00:34|CVR|HOT-1: looks like we're good to go here. it uh basically what it said was. trim's on.  
pack selector A. I hit the reset.

The PF flew the aircraft manually to an altitude of 11,300 feet, then engaged the AP for ascent to a cruising altitude of 32,000 feet.

Just prior to reaching the selected altitude of 32,000 ft at 15:12:53 the master warning light illuminated and the fire warning bell sounded.

The master warning coincided with a DFDR discrete signal for fire on the forward main deck.



Figure 38: Fire Audible Alarm - 15:12:53 UTC

Fire Warning Master Warning Light/Audible Alarm

When the first fire warnings occurred, the aircraft was configured for Climb/Ascent:

Flaps up

Speed 302 knots  
Heading 295 degrees  
Altitude ~32,000 feet  
100% Engine N1  
AP engaged in Vertical Navigation (VNAV) / Lateral Navigation (LNAV) modes

Following indication of fire on-board the aircraft, the flight crew initiated a descent and in-flight turn back to DXB.

15:12:58 - Alert: Fire Main Deck Fwd

15:13:02 - Captain assumed control of the aircraft and decided to return to DXB. Captain took control of the radio and instructed the F/O to run the checklist.

- 15:12:57|CVR|CAPT: fire, main deck forward. Alright, I'll fly the aircraft
- 15:13:07|CVR|CAPT: I got the radio, go ahead and run [the checklist]

15:13:09 (ATC) Captain contacted Bahrain Area East Control.

- 15:13:14|CVR|CAPT: Just got a fire indication on the main deck I need to land ASAP
- 15:13:19|CVR|[BAE-C ]: Doha at your ten o'clock and one hundred miles is that close enough?
- › AP Modes: LNAV was changed to Heading Select and VNAV was changed to Flight Level Change (FLC).
- › Auto throttle (A/T) transitioned from climb to cruise mode, as the target altitude was reached, and thrust decreased.

Inflight Turn back

Inflight turn back/Emergency descent en-route.

- 15:13:19|CVR|BAE-C: Doha at your ten o'clock and one hundred miles is that close enough?
- 15:13:23|CVR|CAPT: how about we turn around and go back to Dubai, I'd like to declare an emergency
- 15:13:27|CVR|BAE-C: UPS six make a right turn heading zero nine zero descend to flight level two eight zero.

15:13:31 - Selected heading on the Mode Control Panel (MCP) was changed from 295° to 90° for the turn back to DXB.

15:13:46 - Fire Main Deck

- › The flight crew changes their selected altitude from 32,000 feet to 28,000 feet. A/T began decreasing thrust to start the decent.
- › Selected heading was changed again to 130 degrees 170 seconds later.
- › Descent – flight crew began a turn back to DXB while descending to 10,000 feet.
- › The first indications of flight control issues are present in the FDR data, and the flight crew's CVR comments<sup>77</sup>.

15:14:02 - AP manually disconnected

15:14:05 - *Pack 2, 3 OFF*

---

<sup>77</sup> The flight control anomalies are reviewed further in the Flight Controls section.

- CVR|CAPT: packs two and three off. get your oxygen mask on
- CVR|F.O: okay. pack two and three off.

15:14:16 - *AP ON*

15:14:28 - *AP manually disconnected*

15:14:40 - *Fire Main Deck Zone 12*

15:15:00 - *Altitude Select 10,000 feet*

15:15:15 - *Crew Rest Smoke*

15:15:21 - *Pack 1 OFF (All packs off)*

The fire suppression systems system shuts down automatically PACKS 2 and 3, the PACK 2 and 3 switch positions were then manually selected to OFF on the overhead panel in accordance with the NNC. This action was recorded on the CVR, with a direct correlation on the DFDR information.

At 15:15:21 Pack 1 is reported OFF by the FDR for unknown reasons. When Pack 1 goes off, no packs are operating, resulting in a loss of all ventilation to the upper deck and flight deck

The flight crew were flying, manually inputting positive and negative column deflections.

15:15:47 UTC – Inflight Turn back/Pitch Control Problem

The data labelled 'F/O Column Force' tracks the 'Captain Column Force' for the entire flight until time 15:15:21 seconds. From this point to the end of data, F/O column force reads close to zero. The two control columns are linked by a torque tube.

- 15:15:23|CVR|CAPT: I need a descent down to ten thousand right away sir

The reason for the immediate descent was never clarified in the available data. The checklist calls for either a climb or descent to 25,000 ft or to land at the nearest suitable aerodrome.

There may have been circumstances in the immediate cockpit area which prompted the Captain to take this action. As the fire suppression methodology is based on depressurisation and oxygen deprivation, this action would have exacerbated the fire and smoke problem.

15:15:28 – Alert: Fire Main Deck AFT

Lack of Control - Pitch

15:15:37 - Captains first comment about lack of control

- 15:15:37|CVR|CAPT: alright. I've barely got control
- 15:15:38|CVR|F.O: I can't hear you
- 15:15:41|CVR|CAPT: Alright
- 15:15:47|CVR|F.O: alright... find out what the hell's goin on, I've barely got control of the aircraft.
- › The FDR column deflection began to deviate from zero in the nose-down direction. The Captain's column force indicates that the captain was actively inputting nose-down and nose up forces on the column.
- › The FDR data show multiple left rudder pedal inputs but there was no corresponding rudder pedal force. The rudder pedal movement does not have a corresponding rudder deflection.

15:15:40 - *Cabin Altitude Warning*

15:15:48 - CAPT - Second comment about lack of control

- 15:16:41|CVR|CAPT: I have no control of the aircraft.
- 15:15:43|CVR|F.O: okay... what?
- 15:16:47|CVR|CAPT: I have no pitch control of the aircraft
- 15:15:53|CVR|F.O: you don't have control at all?

15:15:59 - *Fire Cargo Aft / Zone 1 (lower deck)*

- › Column deflection moves to full nose-down deflection. The elevator deflection is not consistent with the nose-down deflection recorded for the column deflection parameter.
- › FDR elevator data show little to no deflection while there are large deflections in column position. The flight path of the aircraft, following the fire indications, is consistent with the elevator deflections.
- 15:16:42|CAPT: I have no control of the aircraft.
- 15:16:47|CAPT: I have no pitch control of the aircraft.

15:16:57 - *Fire Zone 2 Aft Cargo (lower deck)*

- 15:16:57|CAPT: pull the smoke handle.

Pulling the smoke handle was not a checklist item for this emergency. The smoke handle stays open for the duration of the flight. With no effective smoke barrier, no Packs in operation for positive pressure smoke control, the smoke handle open could have caused a pressure differential when the smoke shutter was open, thereby drawing more smoke into the cockpit.

15:17:05 - *Fire Zone 3 Aft Cargo (lower deck)*

15:17:19 (ATC) - Captain informed ATC that cockpit was full of smoke

- 15:17:39|RDO-CAPT: UPS six we are full,- the cockpit is full of smoke attempting to turn to flight to one thirty please have (men and equipment) standing by in Dubai.

15:17:38 CAPT - Comment about inability to see intra-cockpit

- 15:17:39|CVR|CAPT: Can you see anything?
- 15:17:40|CVR|F.O: No, I can't see anything.

15:17:44 - *AP On*

The AP controls the elevators directly from the aft quadrant (AP commands appear to be unaffected by the flight controls issues observed in the data and reported by the crew.

FMS Input

15:17:51 - CAPT - First discussion about trying to input DXB into the FMS

- 15:18:01|CVR|CAPT: try and get Dubai in the flight management system..
- 15:18:02|CVR|F.O: I can't see it.
- 15:18:05|CVR|CAPT: What frequency?
- 15:18:09|CVR|CAPT: Okay.
- 15:18:10|CVR|F.O: Okay.
- 15:18:11|CVR|CAPT: I'm just levelling out.
- 15:18:12|CVR|F.O: I got the mask.
- 15:18:26|CVR|F.O: You're level at twenty two twenty two thousand.
- 15:18:30|CVR|CAPT: Okay. I'm just tryin to see
- 15:18:39|CVR|F.O: Can you- you're level at twenty two thousand.

- 15:18:42 | CVR | CAPT: Let's just get a uh...straight in to twelve left.
- 15:18:46 | CVR | F.O: Twelve left okay.

15:19:20 – DFDR - The Instrument Landing System (ILS) was tuned to a frequency of 110.1

- › The ILS frequency for DXB Runway 12L is 110.1

The Captain makes a comment concerning the lack of oxygen.

This CVR excerpt indicates the following exchange between the Captain and F/O concerning the mask operation and the alternative oxygen supply bottle location. The exchange begins when the CAPT's oxygen supply stops abruptly with no other indications that the oxygen supply is low or failing.

The exchange is 1 minute 45 seconds in duration.

- 15:19:56 | CVR | CAPT: I've got no oxygen.
- 15:19:58 | CVR | F.O: Okay
- 15:20:00 | CVR | F.O: Keep working at it, you got it.
- 15:20:02 | CVR | CAPT: I got no oxygen I can't breathe.
- 15:20:04 | CVR | F.O: okay okay.
- 15:20:06 | CVR | F.O: what do you want me to get you?
- 15:20:08 | CVR | CAPT: Oxygen.
- 15:20:11 | CVR | F.O: Okay
- 15:20:12 | CVR | CAPT: Get me oxygen.
- 15:20:12 | CVR | F.O: hold on okay.
- 15:20:16 | CVR | F.O: Are you okay?
- 15:20:17 | CVR | CAPT: (I'm out of) oxygen.
- 15:20:19 | CVR | F.O: I don't know where to get it.
- 15:20:20 | CVR | CAPT:(I'm out of) oxygen.
- 15:20:21 | CVR | F.O: Okay
- 15:20:21 | CVR | CAPT:You fly (the aircraft)

CAPT - Comment about transfer of aircraft control to F.O (now PF)

The Captain moves to the aft of the cockpit area

- 15:20:41 | CVR | CAPT: I can't see

No ACAR/AHM data is transmitted concerning low oxygen level

- 15:20:41 | CVR | Relay: UPS your altitude is one six thousand four hundred.
- 15:20:41 | CVR | PF: I hear you I'm looking for some oxygen one six thousand four hundred.

15:21:00 to 15:25:59 - AP ON

- 15:25:42 | CVR | PF: I would like immediate vectors to the nearest airport I'm gonna need radar guidance I cannot see
- 15:25:48 | CVR | Relay: okay Bahrain he request radar vectors to the nearest airport he cannot see
- › *ALT Hold Mode ENG*
- › *Computed Airspeed 350 knots*
- › *Heading 100 degrees*
- › *20,000 feet pressure altitude to 10,000 feet*
- › *Throttle Resolver Angle: 60 degrees*

15:26:00 – Flt Change mode OFF

- › *ALT mode ON*
- › *ALT Hold Mode ON*

15:26:09 - Selected Altitude was captured at 10,000 feet

Transit to DXB Intermediate Approach Fix

This phase of the flight is direct to DXB. AP on and the PF is talking to the relays aircraft asking for spatial information - relative position, heading, altitude and airspeed.

Judging by the transmissions, the PF has very limited information. The heading select/speed select/altitude select windows are visible, but not the PFD or Navigation display, the PF can judge what has been demanded but not the response.

There are several references to the smoke in the cockpit, the inability to view inside or outside the cockpit, the increasing heat, lack of oxygen supply and that the PF cannot see the primary flight displays speed or altitude indicators.

The following is the eight minutes of CVR up to the over flight of the DXB RWY12L northern boundary Identifiers for the transmissions are below:

- › PF: Pilot Flying/Accident Flight
- › 751- Relay A/C
- › 159- Relay A/C
- › 229- Relay A/C
- › D01- Relay A/C
- › EACC – UAE Area Control
- › Unk/Unk1,2,3 – Unidentified radio transmissions

CVR transcript for time period 15:26:01 - 15:36:53

- 15:26:01 | CVR | 751: okay - UPS six just stand by
- 15:26:04 | CVR | PF: roger that.
- 15:26:06 | CVR | PF: what is my current altitude?
- 15:26:09 | CVR | 751: okay ah UPS six current ah nearest airport is Dubai ah Bahrain what is the current altitude of UPS six
- 15:26:23 | CVR | 751: okay uh but now ah he is at one one thousand confirm?
- 15:26:28 | CVR | 751: yes UPS six you are at one one thousand feet nearest airport is Dubai
- 15:26:33 | CVR | PF: nearest airport is how far?
- 15:26:36 | CVR | 751: ah Dubai. standby. how far from ah Dubai from the aircraft Bahrain
- 15:26:42 | CVR | 751: standby please.
- 15:26:43 | CVR | PF: sir you're gonna need to work faster give me a heading direct to the runway at Dubai and give me immediate vectors.
- 15:26:51 | CVR | 751: okay Bahrain say again please?
- 15:27:25 | CVR | 751: Bahrain Sky Dubai seven five one?
- 15:27:29 | CVR | 751: UPS request UPS six request radar vectors to the runway using Dubai direct vectors runway using Dubai
- 15:27:41 | CVR | 751: all right UPS six just standing by for a while please.
- 15:27:44 | CVR | PF: sir give me a heading right now what is my current heading?
- 15:27:51 | CVR | PF: sir give me a give me a frequency now.



- 15:27:55 |CVR| 751:okay ah Bahrain ah UPS asked for a frequency now.
- 15:28:12 |CVR| 751:okay UPS six you are seventy eight miles from Dubai runway one two frequency now one one eight seven five.
- 15:28:26 |CVR| 751: okay now we understood okay Bahrain he cannot see the radio he must keep the ah ah frequency and he asked for current altitude and vectors to runway one two
- 15:28:42 |CVR| 751:okay your current altitude UPS six is niner thousand and fly the present heading
- 15:28:48 |CVR| PF okay fly present heading niner thousand roger
- 15:28:52 |CVR| 751: say again UPS six?
- 15:28:55 |CVR| PF: I said I'm flying the current heading my heading reads as one zero five and my altitude reads as one zero thousand what do you see for an altitude?
- 15:29:05 |CVR| 751: okay Bahrain Bahrain gives you nine thousand altitude you are at nine thousand feet and a heading one zero five is okay to Dubai.
- 15:29:14 |CVR| PF:roger
- 15:29:16 |CVR| 751:Bahrain UPS six roger
- 15:29:59 |CVR| PF:okay Bahrain give me what is my current airspeed?
- 15:30:07 |CVR| PF:current airspeed immediately immediately.
- 15:30:14 |CVR| PF:what is my distance from Dubai International UPS er six what is my distance we are on fire it is getting very hot and we cannot see.
- 15:30:22 |CVR| 751:okay I ask Bahrain understood and UPS six request the distance from Dubai from now?
- 15:30:28 |CVR| PF:sir I need to speak directly to you I cannot be passed along I need to speak directly to you I am flying blind.
- 15:30:36 |CVR| 751: understood UPS six we are just changes to another aircraft to be with Dubai to relay with you I ask again to Bahrain Bahrain distance UPS six to Dubai?
- 15:30:49 |CVR| PF:sir what is my distance to Dubai International and what is my current altitude immediately sir?
- 15:30:59 |CVR| 751: okay UPS six you are currently six zero miles from the airport .
- 15:31:04 |CVR| PF:sir what is my altitude?
- 15:31:06 |CVR| 751: and uh the altitude please?
- 15:31:11 |CVR| 751: nine thousand six hundred UPS six
- 15:31:14 |CVR| PF: nine thousand six hundred roger am I on a vector for the runway?
- 15:31:21 |CVR| 751:yes you are on vectors to the runway one two in Dubai
- 15:31:22 |CVR| 159: Sky Dubai seven five one can you hear Sky Dubai one five nine on one two one five?
- 15:31:28 |CVR| PF:roger we're gonna need to speed this up sir we need to hurry you're gonna need to give me radar guidance to the runway I can not see.
- 15:31:34 |CVR| 159:Sky Dubai two zero one, are you on Guard?
- 15:31:36 |CVR| 751: Bahrain Sky Dubai seven five one.
- 15:31:44 |CVR| 159:yeah we're calling Sky Dubai two zero one or Sky Dubai seven five one, this is Sky Dubai one five nine.
- 15:31:47 |CVR| 751:Sky Dubai seven five one ah UPS six that he's ah hurry needs vectors at land in Dubai.
- 15:31:56 |CVR| PF:sir we are running out of oxygen.
- 15:32:00 |CVR| 159:Sky Dubai two zero one are you on Guard, one two one decimal five?
- 15:32:05 |CVR| PF: sir please give us a vector to the final approach.

- 15:32:10 |CVR| 159: Sky Dubai seven five one can you read us on Guard, one two one five?
- 15:32:11 |CVR| 751: Bahrain this is Sky Dubai seven five one.
- 15:32:17 |CVR| 159: if you can read us Sky Dubai seven five one contact us one two seven five two five, one two seven five two five.
- 15:32:18 |CVR| PF:sir UPS six what is my current altitude and heading immediately?
- 15:32:23. |CVR| 229:yeah Sky Dubai two two nine is reading (you/him).
- 15:32:25 |CVR| 159:and for Sky Dubai two zero one, they need (any?) relay help on one three two one two, with UPS
- 15:32:33 |CVR| 229: Ok UPS you are at five zero miles now from Dubai airport.
- 15:32:38 |CVR| UAE:flight calling, this is UAE.
- 15:32:38 |CVR| PF:roger what is my altitude sir?
- 15:32:41 |CVR| 229:and he needs his altitude readout, also.
- 15:32:43 |CVR| 159: Sky Dubai one five niner.
- 15:32:45 |CVR| PF: what is my altitude sir?
- 15:32:50 |CVR| UAE: Sky Dubai one five nine, UAE on Guard.
- 15:32:18 |CVR| PF: sir UPS six what is my current altitude and heading immediately?
- 15:32:23 |CVR| yeah Sky Dubai two two nine is reading (you/him).
- 15:32:25 |CVR| 159: and for Sky Dubai two zero one, they need (any?) relay help on one three two one two, with UPS
- 15:32:33 |CVR| 229:ok UPS you are at five zero miles now from Dubai airport.
- 15:32:38 |CVR| EACC:flight calling, this is UAE.
- 15:32:38 |CVR| PF:roger what is my altitude sir?
- 15:32:41 |CVR| 229: and he needs his altitude readout, also.
- 15:32:43 |CVR| 159: Sky Dubai one five niner.
- 15:32:45 |CVR| PF:what is my altitude sir?
- 15:32:50 |CVR| EACC:Sky Dubai one five nine, UAE on Guard.
- 15:32:52 |CVR| 229: height is nine thousand six hundred feet now, five zero miles out of uh the Dubai airport, you have it at twelve o'clock.
- 15:32:56 |CVR| 159: Sky Dubai one five nine is on with Bahrain one two seven five two five.
- 15:33:01 |CVR| PF:sir we are flying blind, I have no visual my indicator says ten thousand feet, I cannot see out the window, we're gonna have to work together on this one, I'd like to descent to nine thousand feet.
- 15:33:01 |CVR| EACC:Sky Dub- Sky Dubai one five nine, thank- uh thanks for your help. I think the UPS six is now talking to Dubai frequency and he's uh three zero miles from the field.
- 15:33:12 |CVR| 159:one five niner.
- 15:33:15 |CVR| 229:two two nine, go ahead.

15:33:19 - Altitude Select 9,000 feet

- 15:33:21 |CVR| 229: that's a negative uh he's flying blind and he needs your vectors for coming into the Dubai airport.
- 15:33:32 |CVR| PF:sir I'm descending to niner thousand feet.
- 15:33:43 |CVR| PF:sir, what is my altitude.
- 15:33:48 |CVR| Unk0:uhh. blocked.
- 15:33:51 |CVR| PF:UPS six, what is my altitude sir?
- 15:33:55 |CVR| D1: Bahrain, Dubai one go ahead.

- 15:34:02 | CVR | D1:ok go ahead sir.
- 15:34:21 | CVR | D1: alright eh, what do you want me to tell UPS six?
- 15:34:30 | CVR | D1:uh three-uh UP six from Dubai one, uh - three zero zero at four.
- 15:34:41 | CVR | D1: uh currently three two DME.
- 15:34:50 | CVR | D1:and tower clears you to land, one two left.
- 15:35:00 | CVR | D1:UPS six UPS six you are cleared to land one two left cleared to land one two left.
- 15:35:10 | CVR | PF: mayday mayday UPS six can anybody hear me. [appears to be transmitting on 121.5Mhz only]
- 15:35:12 | CVR | D1:negative.
- 15:35:14 | CVR | PF:UPS six can you hear me. [appears to be transmitting on 121.5Mhz only]
- 15:35:18 | CVR | Unk1: UPS six are you on Guard?
- 15:35:19 | CVR | D1: UP six, this is Dubai zero zero one relay from Dubai tower, clears you to land one two left.
- 15:35:23 | CVR | Unk:UPS six go ahead.
- 15:35:29 | CVR | PF:sir we are going to need a heading, we have no heading and no altitude readout. can you give us ra- precision radar guidance.?
- 15:35:33 | CVR | Unk1:UPS six, go ahead
- 15:35:36 | CVR | D1: all right uh they are requesting precision radar guidance they've got uh they've got no heading.
- 15:35:41 | CVR | Unk2:traffic on Guard repeat your message, repeat your message.
- 15:35:44 | CVR | PF:yes sir we have no- we can see nothing here, we're flying blind. tell me what to do. what altitude, what speed, what heading?
- 15:35:51 | CVR | D1:okay they want to know what altitude, what speed, what heading they've got. they're flying blind at the moment.
- 15:35:58 | CVR | D1: okay, standby one UP six.
- 15:36:01 | CVR | PF: roger.
- 15:36:04 | CVR | Unk3: Sky Dubai two zero one, one two one five please.
- 15:36:17 | CVR | PF:you're gonna have to do better than that.
- 15:36:20 | CVR | D1: UPS six you're now two zero DME from the field.
- 15:36:25 | CVR | PF: roger we're descending to four thousand.
- 15:36:31 | CVR | D1:turn right ten degrees UPS six.
- 15:36:43 | CVR | D1:and the ILS frequency one one zero point one.
- 15:36:47 | CVR | PF: sir I cannot see to tune that I cannot see.
- 15:36:51 | CVR | D1: you were stepped on, say again?
- 15:36:53 | CVR | PF: we cannot see to tune it, you're gonna have to guide us in.

Approach to DXB/Intermediate Fix [approach].

Aircraft configuration on the approach to DXB RW 12L was

- › Flaps up
- › Computed Airspeed 350 knots
- › Heading 100 degrees
- › Altitude 9,000 feet
- › Throttle Resolver Angle: 60 degrees

The glide slope (G/S) deviation parameter goes from negative to positive at this time<sup>①</sup>. This indicates that the aircraft was passing from below to above the beam. Based upon the distance from the Runway

12L glide slope transmitter (at DXB) and the altitude of the aircraft, the beam that was crossed was the 3 degree beam. G/S mode was not armed at this time.

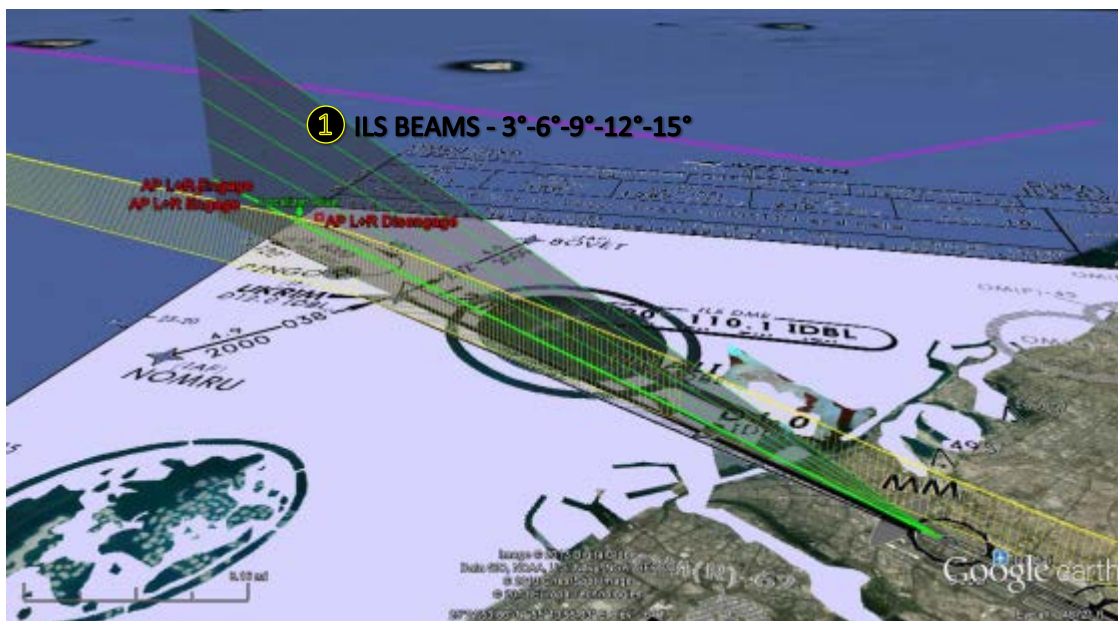

Figure 39 DXB RWY 12L ILS Intercept

15:36:46 - *G/S Armed, Localizer Armed*

- › The flight crew selects the “Approach” push button on the MCP. This selection triggers the G/S and localizer modes to arm. At the same time, the left and right AP channels armed.

Altitude Select 4,000 feet

15:37:06 - *G/S mode engaged*

- › The aircraft receivers detect DXB Runway 12L glide slope beam and the criteria for G/S capture are satisfied. This causes a switch from G/S Armed to G/S Capture Mode. The distance/altitude combination at the time of capture corresponds to the 6 degree false node of the glide slope signal for Runway 12L.

15:37:21 - *AP 1 and 3 Off, V/S, Descent*

- › Engaging V/S Mode disarms the left and right AP channels
- › The Vertical Mode for AP was V/S Descent (disengages G/S Mode)
- › The Lateral Mode remains in Heading Select Mode. The AP never transitioned into localizer Mode while Localizer was armed.

The speed of the transition and the high aircraft speed as it intercepted the localiser would not have allowed the localiser mode to switch to armed. The aircraft had transition through the ILS beam and was abeam the northern aerodrome boundary.

- 15:37:02 |CVR|Unk4: UPS six say you're message again?
- 15:37:04 |CVR|D1: okay, he just needs heading to the runway, that's all.
- 15:37:06 |CVR|PF: turn me to the runway, lets go.
- 15:37:09 |CVR|D1: heading one one five now, UP six.
- 15:37:11 |CVR|PF: roger, one one five. roger- am I doing one one five? tell me my heading.

- 15:37:18 |CVR|D1: ok you are now eleven DME, eight miles from the field.
- 15:37:23 |CVR|PF: mayday mayday.
- 15:37:25 |CVR|PF: roger. eleven DME. what's my altitude?
- 15:37:28 |CVR|D1: uh, what's his altitude, uh uh Bahrain?
- 15:37:34 |CVR|D1: uh you're nine miles, seven thousand feet

15:37:45 - V/S Select -2000 fpm

- 19:37:49.6 |CVR|D1: okay, nine miles, seven thousand feet. UP six.
- 19:37:57.0 |CVR|D1: uh, you're now six miles.

15:38:00 - V/S Select -2700 fpm

15:38:02 - V/S Select -3500 fpm

- 19:38:03.5 |CVR|D1: uh, you're too fast and too high can you make a three sixty?
- 19:38:08.2 |CVR|PF: negative, negative, negative.

#### DXB – Missed Approach

Missed Approach - The PF continues to prepare the aircraft for landing. MCP inputs are not consistent with the phase of flight and ATC directions.

Aircraft configuration:

- › Flaps up
- › Speed 353 knots
- › Heading 115 degrees
- › Altitude 6,500 feet
- › Throttles: Approach Idle
- › Speed Brakes: Armed

15:38:04 (ATC) - The relay aircraft advised the crew that the aircraft was 'too high and too fast', and asks if the crew can make a 360 degree turn. The PF responds 'Negative, negative, negative'

15:38:05 - Gear Lever Down

15:38:09 - Speed Brakes Extended

- › Speed brake handle was extended to in-flight detent. Spoilers deflected less than expected<sup>78</sup>.

15:38:12 - Flap Lever Selected to 20

15:38:17 - Flap Lever Selected to 30

- › The Flap load alleviation system prevents the flaps from deflecting to 30 degrees. This was due to the fact that the airspeed was above flaps 20 placard speed (225 knots).

Placard Speed

---

<sup>78</sup> See Section 2– Flight Controls

### Flap Limit Placard

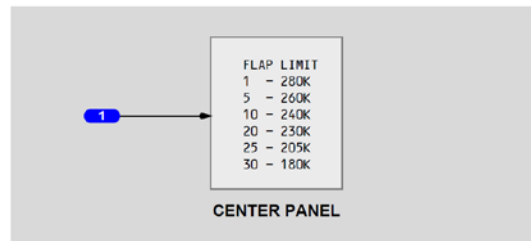

**1** Flap Limit Placard  
Flaps extended speed limits.

Figure 40 - Placard Speed

### Landing Configuration Warning

The landing configuration alert warning system alerts the crew the landing gear is not extended for landing - the EICAS warning message CONFIG GEAR is displayed

15:38:20 - Transition to Altitude Capture

15:38:20 - PF comment that the landing gear was not functioning

- 15:38:20|CVR|PF: I have no, uh gear
- › Airspeed began to deviate below the Selected MCP Speed. When the A/T was engaged in Speed Select Mode and the airspeed was above placard speed (Flaps 20 - 225 knots), A/T will limit the airspeed to the placard speed for the given flap setting.

15:38:30 - Altitude Select 1500 feet

15:38:37 - *Gear Disagree*

- › This discrete indicates that the landing gear are not in agreement with the position of the gear lever. This correlates with comments made about the gear not functioning.
- 15:38:37|CVR|PF: Sir, where are we. Where are we located?

15:38:39 the relay asks if the PF can make a left turn toward Sharjah airport, 10 nm to the aircraft left which has a parallel runway. The PF responds asking for the heading. The relay aircraft responds '095 deg'.

- 15:37:57|CVR|Relay: Are you able to do a left turn now, to Sharjah, its ten miles away?
- 15:37:57|CVR|PF: Gimme a left turn, what heading?
- 15:37:57|CVR|Relay: What sort of heading, Bahrain?
- 15:37:57|CVR|PF: Hurry up, what heading?
- 15:37:57|CVR|Relay: Okay heading zero nine five, you're on final for Sharjah



Figure 41 DXB Over Flight and Relay Communication

15:38:45 - Heading bug to 110 deg

15:38:50 - Flaps 20

15:38:59 - Speed Select 360

15:39:00 - Heading bug to 115 deg

15:39:07 - Heading bug to 195 deg

15:39:12 - (Comms ATC) - PF acknowledges a heading of 095 for Sharjah airport

- › The PF after being cleared to Sharjah Airport (SHJ), selected a different heading than cleared, the MCP input is 195 deg for an undetermined reason.

15:39:19 - GPWS: Bank Angle



Figure 42 DXB RWY 12L Over Flight



Figure 43 - GPWS: Bank Angle Warning - 15:39:19 UTC

The aircraft rolls rapidly to acquire the new selected heading, reaching a max right bank angle of 37.5 degrees, before rolling wings level.

- 15:40:20 | CVR | PF: What is my altitude, and my heading?
- 15:40:25 | CVR | PF: my airspeed.
- 15:40:28 | CVR | Relay: What's his airspeed?
- 15:40:33 | CVR | PF: Altitude?
- 15:40:35 | CVR | PF: Altitude?
- 15:40:40 | CVR | PF: Give it to me now

15:39:19 UTC - GPWS: Bank Angle Warning

15:39:29 - Thrust increased manually (airspeed is still above flap placard of 225 knots)

15:39:56 - Speed Select 325kts

Airspeed increases so A/T again returns throttle to idle in an attempt to maintain the flaps 20 placard speed (225 knots).

15:40:05 - AP manually disconnected

Following the disengagement of the AP, the aircraft pitched down to -14 degrees and



began to descend. The transducer measuring the Captains column force and column deflection display rapid nose-up pitch commands during the final 40 seconds. Elevators moved with the nose-up column inputs but the deflection was inconsistent with the relationship seen at the beginning of the flight.

Aircraft heading crossed through the target (195 deg.) and continues as there was no wheel input to return to wings level.



Figure 44 - 15:40:30 UTC Descent Towards Nad Al Sheba

The aircraft responds to the control inputs from the PF and the rate of descent is reduced. There follows a series of pitch oscillations as the control inputs are made. The effect of the inputs on the controllability decrease as the airspeed decreases.

It is possible that the steep descent angle of  $-14^\circ$  may have caused a weight shift forward of some of the remaining cargo, moving the CG forward. This in combination with the reduced throttle setting and reduction in the thrust moment, could cause the aircraft to pitch nose down if uncorrected.

The 747-400 Autothrottle limits the maximum commanded speed to the maximum operating speed (V<sub>max</sub>) calculated by the FMC.

The FMC uses the V<sub>MAX</sub> CONF signal from the Modularized Avionics and Warning Electronics Assembly [MAWEA] for the V<sub>max</sub> when flaps are extended. The MAWEA uses flap position in its calculation. It does not use flap handle position.

The Auto throttle has three functioning modes: Speed/Thrust/Flight level Change.

In speed mode the auto throttle will limit the target speed to be less than or equal to  $V_{cmax}$ .

In thrust mode the auto throttle will set the speed target to  $V_{cmax}$  and let the thrust limiting function limit thrust to the thrust reference value.

According to the Boeing 747 Systems Manual, the Autothrottle and Autopilot Flight Director System (AFDS) independently provide speed protection for all operations except during V/S pitch mode or engine failure above maximum engine-out altitude. Autothrottle speed protection is limited by the reference thrust limit (CLB, CRZ, CON, etc.) and idle. AFDS speed protection is provided through the elevators in the following pitch modes: VNAV SPD, FLCH SPD, or TO/GA.

The DFDR indicates that at 15:33:30 the MCP Speed Mode switches to IAS Engaged, then back to MCP Speed Mode for the duration of the flight. This mode condition remained unchanged.

When the aircraft has the MCP engaged, with A/T set to Speed Mode, with the Flaps set to 20°, the Flaps 20° placard speed for the B747 is 225kt.

The PF made a series of inputs into the elevators which had a limited effect on the descent profile; the descent is arrested temporarily. There then followed a series of rapid pitch oscillations. These were not phugoid oscillations, but commanded responses where the elevator effectiveness decreased rapidly as the airspeed decayed and the elevators could not compensate for the reduced thrust moment from the engines to maintain level flight in a steady state. This was due to the de-synchronisation of the control column inputs and the elevators reduced trailing edge travel.

Had the aircraft remained on this heading and descent profile it would have intercepted the terrain at or near a large urban development, Silicone Oasis.

Below is the descent profile for the sector of the flight just prior to the uncontrolled descent into terrain.



Figure 45 Profile: Descent and Pitch Oscillations

Between 15:41:05 and 15:41:15, approximately ten seconds, the descent is temporarily arrested with a peak positive rate of climb of approximately 800 feet per minute.



Figure 46 Temporary Arrested Descent

15:40:28 - Sink Rate

15:40:28 GPWS – “sink rate”, “pull up”

15:40:28 - Pull-Up

15:40:33 GPWS – “terrain”, “terrain”

15:40:45 Speed Select 280

The PF’s last transmission was at 15:40:49

- 15:40:49|CVR|PF: Sir we cannot, we cannot.

Aircraft crosses through the target altitude of 1,500 feet and levels off as pitch attitude recovers.

15:40:50 - GPWS - “too low”, “terrain”

15:40:56 - Gear Config (Too Low – Gear)

15:40:58 - GPWS - ‘Sink Rate’

15:41:00 - GPWS - ‘Too Low - Terrain’

15:41:07 - GPWS - ‘Five Hundred’

15:41:23 - GPWS - ‘Too Low - Terrain’

15:41:25 - GPWS - ‘Sink Rate. Pull-Up’. Pull-Up’

15:41:29 - GPWS - ‘Pull-Up’

15:41:30 - GPWS - ‘Pull-Up’

15:41:32 - GPWS - ‘Pull-Up’

15:41:33 - GPWS - ‘Pull-Up’

- › The control column is fully aft at 12.3° with minimal elevator deflection.

The collision with the terrain is now inevitable.

15:41:34 - LOC- I/UCFIT: Loss of Control In-flight/Uncontrolled Flight into Terrain/Data Ends.



Figure 47 - 15:41:30 UTC - LOC-I/Loss Of Control In Flight/Data Ends

Summary of the Flight Profile:

The accident flight was uneventful until just before the top of climb at about 15:12, when there was a Fire Main Deck indication and crew audible alert.

As the flight progresses into the Bahrain FIR, approaching the top of climb, the transition from a normal cockpit environment and the emergency reactions by the crew were handled as expected; there was a short reaction time lag based on the startle factor, but the transition to an emergency CRM was quick. There was some alarm expressed at the onset of the emergency.

The Captain had made the command decision to return to Dubai prior to informing BAE-C of the emergency. The F.O was aware of the Captains decision to return and the transition for the configuration changes were established.

Although the crew began the Fire Main Deck non-normal checklist, they did not complete the checklist. The Captain made a decision to return to DXB instead of landing at the nearest suitable airport (Doha)

provided by the BAC-C. Also, the Captain elected to descend to 10,000 feet instead of 25,000 feet per the Fire Main Deck NNC.

There were some communication issues identified early in the sequence, these however did not affect the CRM as the procedures and vital actions were running as predicted.

Three events occurred rapidly and in quick succession following the start of the turn back which diverted the crew's attention.

- I. The cockpit filled with smoke. The smoke was present at the start of the sequence, but it rapidly became noticeable in the CVR statements that the volume and the density of the smoke has increased significantly. Within two minutes neither crew member could view the panels or out of the cockpit.
- II. At about the same time, the pitch control problem became apparent which diverted the F.O's attention as the Captain asked the F.O to 'figure out what was going on'. The F.O was already managing a number of other problems, including the FMC input and the checklist
- III. The Captains oxygen supply stopped, the Captain asked for oxygen, the portable oxygen bottle was behind the Captains seat next to the left hand observer seat. The First Officer was not able to assist the Captain. The Captain, one minute after the oxygen supply stopped, got out of the seat and went back into the aft cockpit area. The Captain was heard to say 'I cannot see', there is no further CVR recording or interaction of the Captain.

Seven minutes into the emergency, the F.O is PF and the Captain is incapacitated. Almost immediately, the first relay aircraft contacts the accident flight to relay information. The F.O establishes communication with the relay, this distraction and the requirement to complete the escalating task load precluded the F.O from enquiring as to the location of the Captain.

This aircraft was on the AP, heading on a direct track to DXB at around 380 KTS. The F.O does not attempt to contact the Captain or mention the incapacitation during the radio transmissions.

There are numerous references to the cockpit visibility problems while the PF is talking to the relay traffic. The following workload factors were considered significant when analysing and demonstrating the basic workload functions for the flight crew.

#### 2.1.2 Basic Workload Functions

##### (1) Flight path control.

- AP from FL220, heading direct to DXB. AP off and manual control from the right turn after the over flight until the end of the data. It is possible due to the smoke and lack of visual clues available spatial disorientation was a factor after the unanticipated bank to the right confused the PF.

##### (2) Collision avoidance.

- The only hazard was following the turn over DXB RWY 12L, the aircraft's descent profile and direction would have intercepted the urban conurbation of Silicone Oasis had the right hand turn not continued.

##### (3) Navigation.

- Marginal. The PF was not aware spatially of the aircraft position relative to the destination aerodrome or the height above the ground. The radio transmissions repeatedly requested

information on height, speed and direction. Several transmissions asked the relays 'Where am I?'

(4) Communications.

- Radio frequency selection and the confused problem around the guard frequency transmissions that were not heard by the PF were not resolved. It is possible the volume was turned down on the RH ACP.
- Had the Captain taken the Doha option, the communications problems experienced by the PF would have been negated as no frequency change was required.

(5) Operation and monitoring of aircraft engines and systems.

- The inability of the PF to view the instruments was a causal factor in the accident. Had this problem been resolved with either an effective smoke abeyance procedure or the fire suppression procedure extinguishing the pyrolysing materials, then only other alternative in a continuously smoke filled cockpit is a vision assistance mechanism

(6) Command Decisions

- The Captain decided to return to DXB at the first fire bell alert. There was a another available airport 100nm from the fire warning location, which could have been achieved in 18- 20 minutes. See section 2.4.

(7) Checklist Interruption.

- Only the initial portions of the Fire Main Deck NNC were completed. As the crew began to experience smoke obscuration and flight control difficulties, the NNC was not completed. In the early stage of the emergency the rapid escalation of the cascading failures occurred while other vital actions were being performed, notably, the Fire Main Deck non-normal checklist. The contact change of prioritisation to deal with the number of problems that were presented to the crew prevented a thorough review of the problems that would be occurring in the near future, for example, tuning one of the radios to the destination frequency.

(8) Psychological Aspects

- Towards the end of the data Just prior to the turn the pilot asks the relay to tell him where are they located. The flight passes over the northern boundary of DXB and performs a steep unanticipated right hand turn. Following this manoeuvre it is possible that confusion resulting from spatial disorientation combined with vestibular disorientation and perception effected the pilot's ability to judge the immediate environment.

## 2.2 Digital Flight Data Analysis

---

The uncontained cargo fire severely damaged the control cables, the truss frame supporting the cables and the cable tension.

The cable tension reduction is the cause of the de-synchronisation, this affected the control function between what the PF commanded and the movement of the elevators. Other flight controls were also affected, the pitch control effectiveness is a contributory causal factor to the accident.

The following is a Digital Flight Data Factual Analysis of the flight controls. It is based on the DFDR. Refer to the Appendices for the Boeing FDR analysis that this summary is based on.

### 2.2.1 Digital Flight Data Factual Analysis - Flight Controls

Background:

At 15:15:37 and 15:15:48 the flight crew commented that there was a lack of control after the autopilot was disengaged while manually flying the aircraft.

- Approximately one minute later, the captain commented that he had no control and specifically no pitch control.
- The response of the flight crew was to engage the AP.
- The AP was able to effectively control the elevator and lateral control system.
- The column position data are consistent with column force inputs from take-off through the first indications of fire.
- Following the fire warnings the F/O column force drops to zero.
- Column position deviates nose-down until it was at the maximum deflection.
- Elevator data during the same period shows only small deflections. This indicates that the column and elevator deflection are inconsistent.

The following issues are observed in the data and recorded from the flight crew comments:

- inconsistency between column input and elevator deflection
- decrease in column forces
- decrease/loss of pitch control
- control column resting at maximum nose-down
- minimal impact on the AP's ability to control aircraft state through elevator commands

All of these indications are consistent with a decrease in elevator control cable tension.

The elevator control system schematic is shown in Section 1. The cable that connects the forward and aft quadrants requires tension for the column movements to translate into elevator movements.

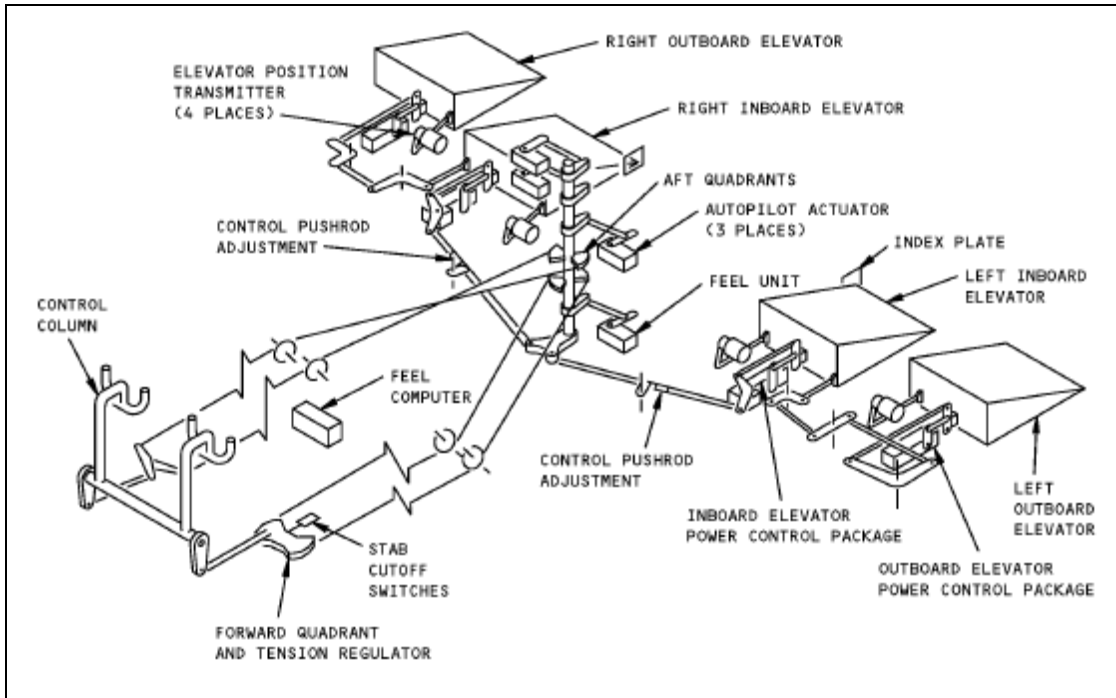

Figure 48 Elevator control system schematic from the Aircraft Maintenance Manual

Inconsistency between column input and elevator deflection

The elevator control system above is designed so that a unit of column deflection creates a unit of movement in the aft quadrant (which in turn moves the elevators). The consistency of this system requires a prescribed tolerance of tension in the elevator control cable.

The figure below indicates the control column sweep and take-off rotation of the event flight.

This represents a normally functioning longitudinal control system as control column input translates to a proportional and predetermined elevator deflection.

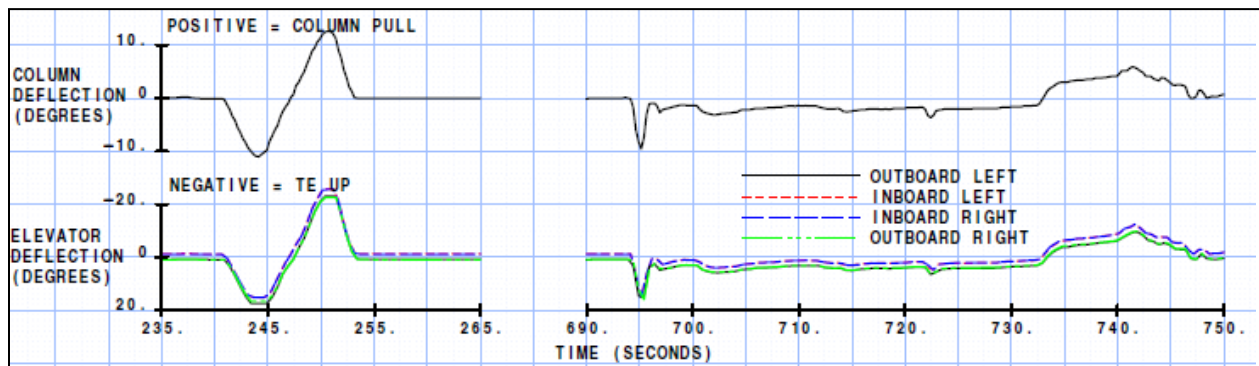

Figure 49 Column sweep and take-off rotation

Column sweep and take-off rotation display the normal relationship between column and elevator. If the tension is below the allowable tolerance, the column and elevator will no longer be consistent.

Following the initial fire warnings the column moved nose-down with no corresponding change in elevator deflection (left plot Fig. 49 above).



Near the end of the data, the FDR data shows nose-up column inputs

The elevator was deflecting with the column inputs but not with the relative magnitude seen in the figure below. This indicates that there was some column cable tension but not enough to maintain normal column to elevator gearing.

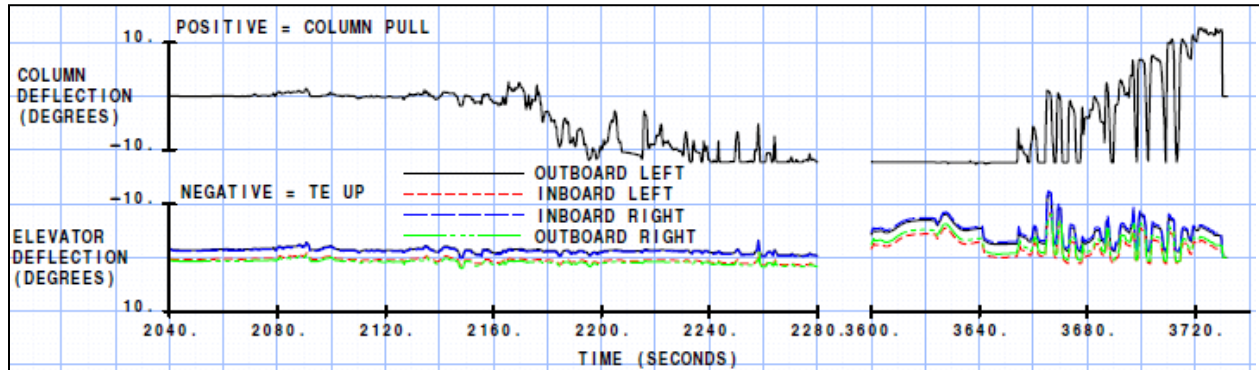

Figure 50 Column to Elevator deflections following the initial fire warnings and just prior to end of data.

Decrease in column forces – the column force transducers are located in the forward quadrant.

The system relies on cable tension to provide the force recorded on the DFDR. Actual column force is then determined by adding the transducer on the captain side with the transducer on the F.O side and multiplying by the mechanical gearing from the transducer to the column. In raw FDR data,

with zero cable tension, the force transducer on that quadrant will read zero.

This effect is observed in the F.O column force parameter (Figure 51 below).

The captain's column force parameter does not go to zero but it does require less force for the same change in column deflection. This is likely due to the fact that the captain's forward quadrant contains a tension regulator that was designed to remove slack from the elevator control cable. In effect the tension for the captain was less than normal but greater than zero while the tension for the F.O was effectively zero.

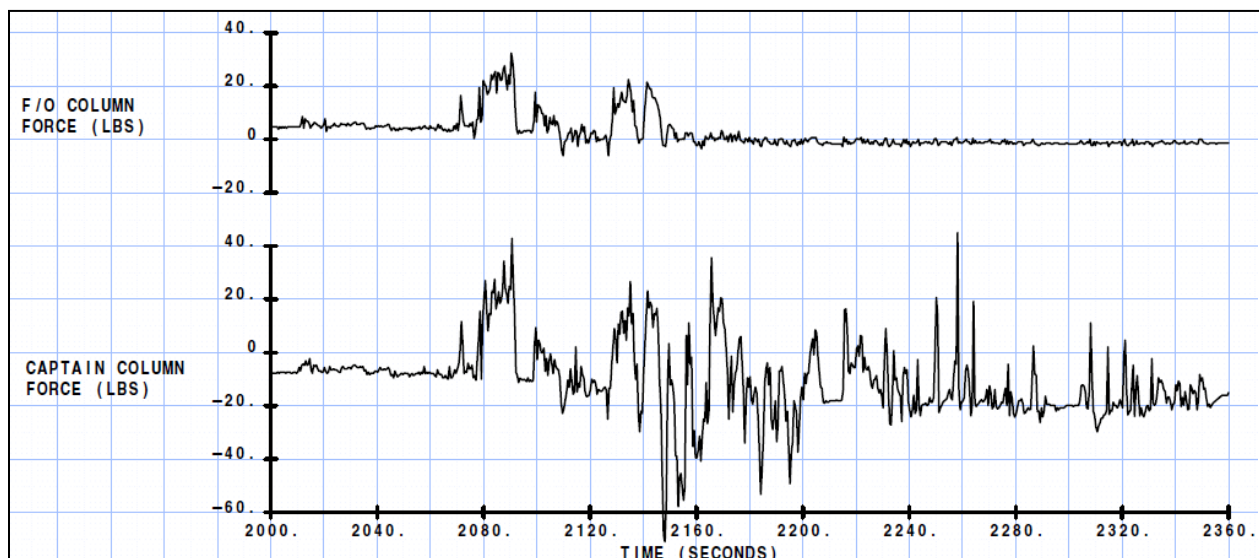

Figure 51 Captain and First Officer column forces following the fire warnings

Note on the Directional Control System:

Decrease/loss of pitch control – the combination of inconsistency between column and elevator and decrease in column force would cause the flight crew to experience a decrease and/or loss of control in the pitch axis.

Control column resting at maximum nose-down – the control column on the 747-400F (or derivative types) will move to the forward stop when there is no tension on the elevator control cable.

Minimal impact on the AP's ability to control elevator – the AP actuator inputs directly into the aft quadrant removing the dependency on elevator control cables.

A loss in cable tension would have no effect on the AP's ability to control the elevators.

The DFDR data indicates that the rudder pedal/rudder directional control system was exhibiting a similar control reduction authority as the column/elevator system.

The figure below shows the relationship between rudder pedal force, rudder pedal deflection, and rudder position.

During the first segment the pedal force moves the pedal. For the rest of the time segment much larger changes in pedal are seen with no pedal force. In addition the 10 degree rudder pedal inputs are not deflecting the rudder. Both of these effects can be caused by a loss in tension of the rudder control cable.

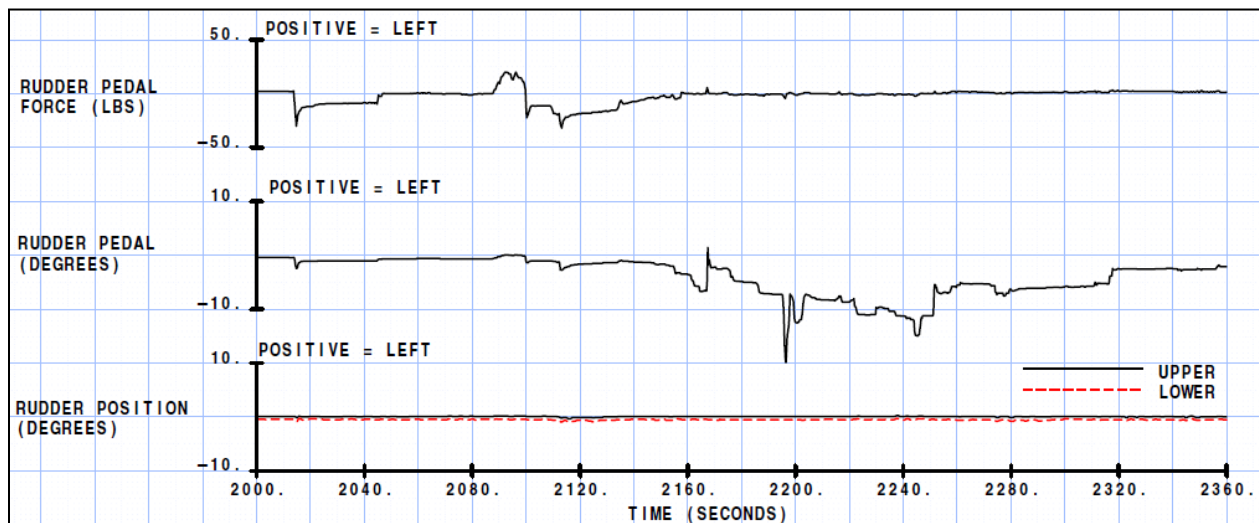

Figure 52 Rudder and rudder pedal data

The Figure below demonstrates the inconsistency between speed brake handle and spoiler deflection – At 15:38:09 to end of flight the spoiler response to speed brake handle when moved to flight detent position was only 3 to 4 surface degrees for flight spoilers #4 and #9 Normal response to speed brake flight detent for these spoiler surfaces would be greater than 25 degrees at the flight conditions. The spoiler panels responded normally to wheel inputs during this time period which demonstrates that these spoiler surfaces had capability to move further. Spoiler deflections are consistent with the flight path of the aircraft.

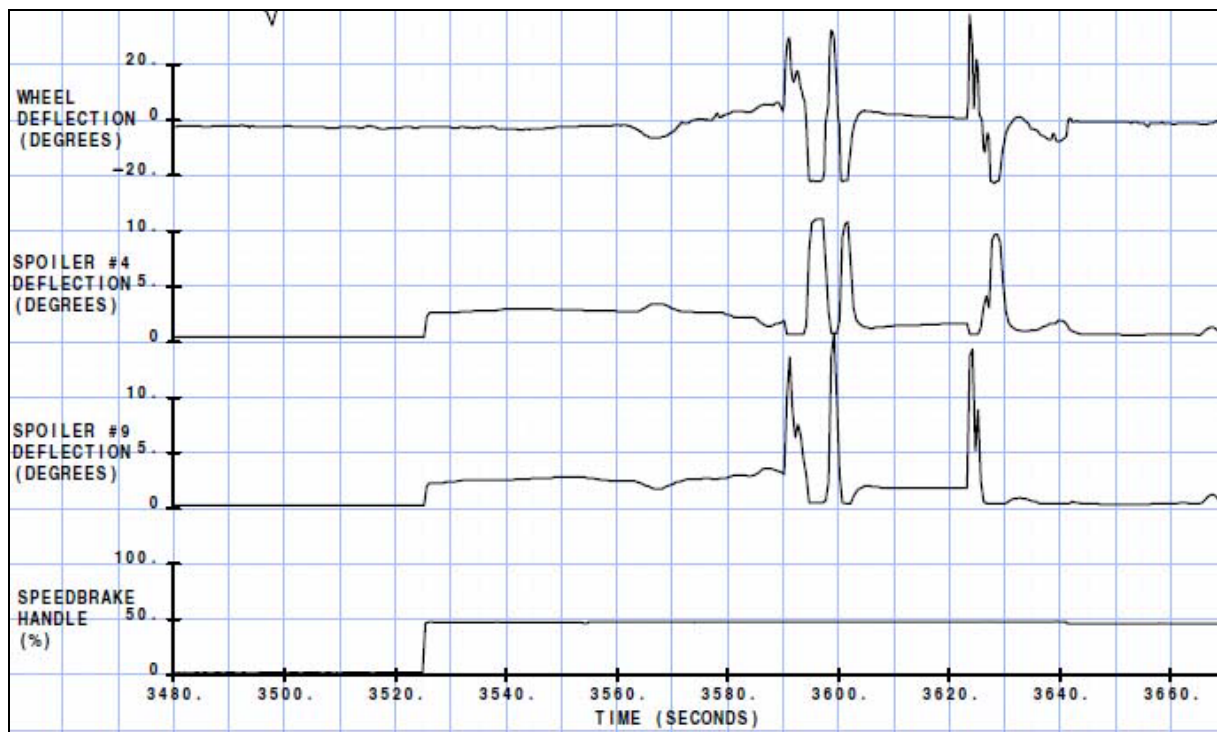

Figure 53 - Spoiler deflection from speed brake handle and wheel deflection

### Autoflight

The Aircraft Health Management System (AHMS) reported the following faults related to the Autoflight system:

Time (s)	ACARS MSG	Flight Control Computer Code	Flight Deck Effect FDE	FDE Type
2317-2377	MODE OPERATION ERROR (FCC)	C243	>Autopilot	CAUTION
2377-2437	STABILIZER-L/FCC-C FAIL	C29	>Autopilot	CAUTION
2377-2437	STABILIZER-R/FCC-C FAIL	C30	>Autopilot	CAUTION

Table 11- ACARS Message Table

### Mode Operation Error

The FDR data indicates that the Mode Operation Error, Flight Control Computer (FCC) Code C24 resulted from a manual override of the A/P at the control wheel during times 2315 to 2321, and at 2328 to 2343 seconds. In addition, the FDR data show that a manual override of the A/P, at the control wheel, occurred during the time 3590 to 3625 seconds.

When the A/P is overridden by a manual input to the control wheel, the engaged aileron servo will cam-out, de-coupling the servo from the aileron control system and the flight crew will have direct control of the ailerons. The cam-out condition will be detected by the aileron detent monitor in the FCC. During the flight, the cam-out condition would have been annunciated to the flight crew with an A/P caution EICAS message, activation of a master caution light, and activation of a caution aural.

During single channel AP operation, the aileron cam-out will not result in an A/P disconnect. The flight mode annunciation will remain in the selected mode. This flight deck annunciation correlated with the maintenance diagnostic code C243, indicating that the aileron detent monitor had tripped.

## Stabilizer Fail

The FDR data show that the stabilizer failures, FCC Codes C29 and C30, resulted from a failure, or inability, of the stabilizer trim system to respond to nose-up autotrim commands from the center FCC. The lack of trim response (or dead trim) occurred at times 2380 to 2494, 3490 to 3514, 3550 to 3562, and 3585 to 3642 seconds. The data suggest that the nose-up dead trim was caused by activation of the nose-up stab trim cut-out switch, due to the movement of the control column to the forward stop.

The FCC will monitor the stabilizer trim system's response to its autotrim-up and autotrim-down requests. During the flight when the stabilizer did not respond, the center FCC, which normally drives the left stabilizer trim system, would auto-sequence over to the right stabilizer trim system.

When the right stabilizer failed to respond, the FCC would annunciate the "dead trim" condition to the flight crew with an AP caution EICAS message, activation of a master caution light, and activation of a caution aural warning. The flight mode annunciation will remain in the selected mode. The flight deck annunciation correlated with the maintenance diagnostic codes C29 and C30, indicating that the trim command response monitor detected a dead trim fault in the left and right trim system, respectively.

## Auto land System Availability

The DFDR data indicates that the auto land system was functioning, as described below:

The AP was able to control the aircraft's pitch axis through the AP elevator servo, and the roll axis through the AP aileron servo.

It is not possible to determine the availability of the AP rudder servos as they are not engaged until multi-channel AP engagement. However the preliminary indications are that there was no data to suggest that they would not be available.

At no time during the flight did the auto land system redundancy downgrade to fail-passive, 'NO LAND 3', or less than fail-passive, "NO AUTOLAND". This suggests that all of the required sensor data were available.

The ILS approach was tuned, and that the data supports that valid ILS data were being provided by the Multi-Mode Receivers (MMRs).

The data supports that the radio altimeters were providing valid radio altitude data.

At one point during the approach, the AP approach mode was selected and the AP transitioned to a multi-channel armed configuration. Some multi-channel pre-engage testing would have been conducted at this time. No failures were annunciated as a result of this multichannel pre-engage testing.

With the landing gear retracted, the MMRs obtain G/S deviation data from the G/S antennas in the nose of the aircraft (capture antennas). With the landing gear extended, the MMRs obtain G/S deviation data from the G/S antennas on the nose gear doors (track antennas).

In the event that it had not been possible to extend the landing gear, it is expected that the auto land system would have been able to conduct a satisfactory approach utilizing G/S deviation data from the capture antennas.

The AP would have transitioned to FLARE mode between 40 feet and 60 feet of radio altitude, and attempted to land the aircraft.

Based on the aircraft manufacturer's analysis, it is not possible to determine the outcome of a gear up automatic landing.

## 747-400 Desktop Engineering Simulation

A 747-400 desktop engineering simulation was used to model the aircraft's flight path for this analysis. The simulation was set up with similar initial conditions (e.g. weight, speed, etc.) and control surface inputs, throttles inputs, and brake inputs to the recorded FDR data.

The indications are a close match in pitch attitude, airspeed and altitude.

This confirms that the elevator inputs and the other flight control surface inputs were consistent with the flight path of the aircraft and support the recorded data that the elevator deflection recorded on the FDR represents the actual surface deflections experienced during the event flight.

### 2.2.2 Summary/Assessment of the DFDR data (Flight Controls)

- The DFDR data show the aircraft performing a normal take off and climb.
- Prior to reaching the selected cruise altitude of 32,000ft, the aircraft systems warned the flight crew of a main deck cargo fire.
- The flight crew initiated a descent and elected to make an emergency return to Dubai International Airport (DXB).
- During descent the flight crew experienced a decrease of manual elevator and rudder control.
- The decrease of manual elevator and rudder control was due to a loss in column and pedal cable tension, respectively.
- The autopilot (AP) does not rely on these cable systems and functioned as expected for the duration of the flight.

### 2.3 Inflight Turn Back To Dubai Verses Diverting To Land At The Nearest Suitable Airport At Doha Or Ditching In The Gulf.

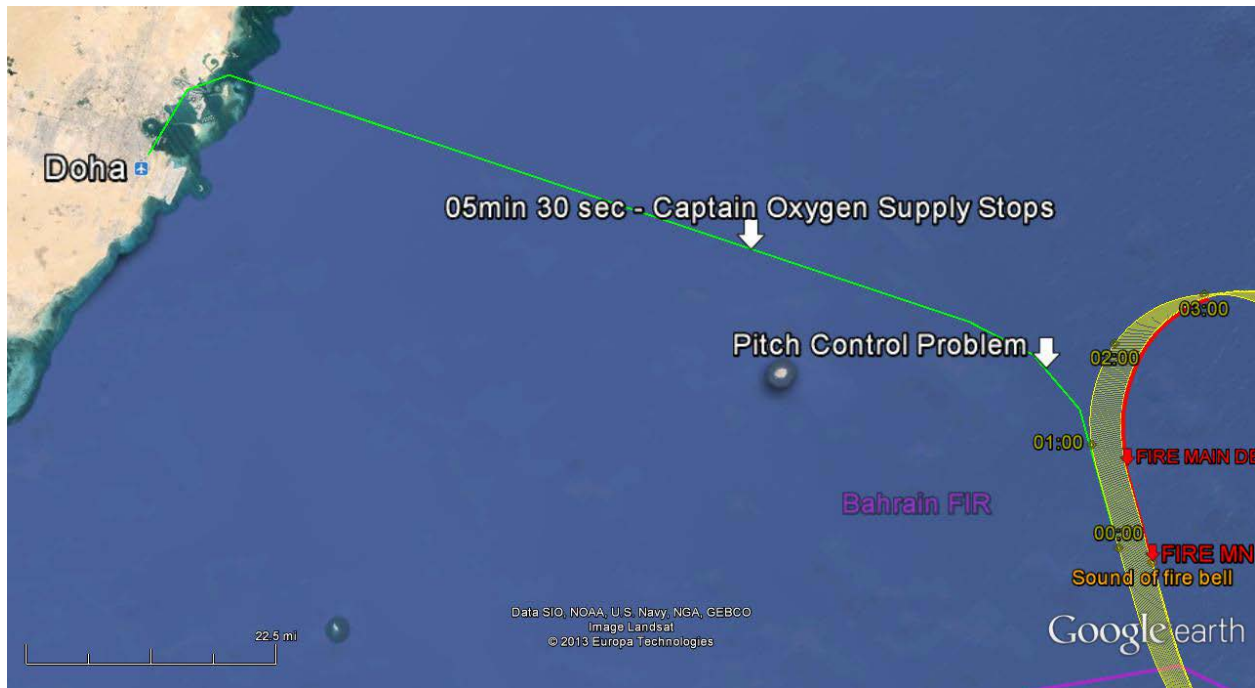

Figure 54 Doha Diversion From Point Of The First Fire Alarm

The Captain's decision to return to DXB instead of the nearest airport option of Doha International Airport [DOH] was not resolved in the various simulator function tests or through any of the other lines of enquiry. From the onset of the emergency the crew reacted to the normal drills required, the Captain assumed control of the aircraft and the F.O was running the QRH Fire Main Deck checklist.

Immediately following the first fire bell, the Captain indicated to the F.O that they would return to DXB. He then advised BAE-C of the main deck fire alarm and that they needed 'to land ASAP'. BAE-C advised that Doha airport was at ten o'clock and 100 nm. The Captain replied that he would turn back to Dubai and declared an emergency.

There is no direct information as to why the crew elected to choose Dubai versus Doha, however, it is likely that at the time of the initiation of the turn back, the crew was not yet aware of the full extent of the fire and its effects.

At 15:13:31, the crew commanded a right turn and descent. Approximately 30 seconds later, the first indications of smoke and control issues became evident to the crew. From the onset of the emergency the crew reacted to the normal drills required, the Captain assumed control of the aircraft and the F.O reverted to Pilot Not Flying [Pilot Monitoring] duties which included running the QRH Fire Main Deck checklist.

A performance analysis for the emergency descent indicate that had the diversion started from the optimum starting point 15:14 UTC, the earliest possible landing time would have been approximately 15:34 UTC at DOH.

### 2.3.1 Factors Influencing Pilot Decision Making During the Diversion/Return To Dubai

When the crew initiated the descent toward Dubai the Captain assessed that the situation was abnormal and had already informed the F.O that they would return to Dubai prior to informing BAE-C of the emergency. There was a request to the controller to land as soon as possible. DOH was advised at 100 track miles. This would have taken 17 minutes to achieve a straight in approach off the sea onto RWY15.

DOH Approach Radar had 121.5 MHz as a listed emergency frequency/RWY 15 ILS frequency was available from the ATCO's if required.

Factors effecting the turn back decision include the following. The crew were familiar with DXB and did not have the DOH charts and FMC information immediately available. The inflight turn-back feature of the FMC automatically reprograms the departure/arrivals page to the departure airport when an air turn-back occurs within 400 nautical miles. This feature gives the pilots immediate access to the arrivals and approaches at the departure airport. The crew would have had recent knowledge of the airport information and weather conditions at DXB.

Based on the limited cues available, the crew took steps to prepare the aircraft for an emergency descent and landing on DXB RWY 12L. At the initiation of the turn to DXB. The crew were familiar with DXB and did not have the DOH approach charts readily available or the ILS Frequency for Doha.

The crew knew that they would have to take additional time to familiarize themselves with, and set up for the approach and landing.

#### Land at Nearest Suitable Airport

The NNC Fire Main Deck checklist provides the instruction in step 8 to *Plan to land at the nearest available airport.*

When the crew advised BAE-C that there was a fire on board, the BAE-C controller advised the crew that DOH was the closest available runway at 100 nm track miles.

The Captain is talking to BAE-C immediately after the fire warning indication.

15:13:14|CVR|CAPT: just got a fire indication on the main deck I need to land ASAP.

15:13:19|CVR|BAE-C : Doha at your ten o'clock and one hundred miles is that close enough?

15:13:23|CVR|CAPT: How about we turn around and go back to Dubai, I'd like to declare an emergency. The F.O is running the checklist and at 15:15:34 calls, '*ok land at nearest suitable airport*' followed almost immediately by the first indication of a control problem and checklist disruption.

This is one of numerous checklist interruption issues identified in the handling of the emergency.

DXB was a track mile distance of approximately 180 nm.

#### Doha Diversion

The investigation examined the possible outcome of an alternative scenario of diverting to DOH at the first indication of the fire. From the point where the diversion to Doha was advised there were 100 track miles to DOH. A performance analysis based on a 3°-4° descent angle and a descent speed of 300kts, indicate that from the notification until overhead DOH could have been achieved in approximately 17 minutes. Adding time for speed reduction and radar vectoring to the approach configuration, approximately 20 minutes would have been required.

Assuming the systems failure timeline remained linear, a similar level of controllability problems would have been apparent, including the oxygen supply problem and the elevator and speed brake problems identified earlier.

Additionally, the landing gear would not have been able to extend unless the crew used the manual gear extension procedure. How an auto landing without landing gear would have concluded is not known.<sup>79</sup> The aircraft was within 20,000 lbs of the take-off fuel, fully loaded and in all probability would have made a wheels up landing.

A descent, based on the fire suppression methodology of venting airflow and depressurisation of the cargo hold to reduce the available oxygen, could have exacerbated the fire, accelerating the cascading failure scenarios and the cascading failures.

However, it is clear that a major difficulty faced by the crew was a consequence of the course change back to DXB. Once the smoke prevented the crew from changing radio frequencies, the communications, navigation, and surveillance difficulties increased. On a course to Doha, the flight would have been in direct contact with BAE-C, and if relays were required as the airplane descended toward the airport, direct landline communication between BAE-C and Doha Approach would have greatly simplified the radio communication. ATC radar surveillance and coordination would also have been simplified. The SSR data would have been available to the ATCO and there would have been more available ambient light due to the longitude of Doha.

Analysis of the diversion to DOH and the likely outcome is speculative as the crew incapacitation and smoke/fumes in the cockpit would have prevailed as the rate of failure on the timeline of the failures was linear regardless of the destination. In addition, the aircraft control was seriously compromised by the fire and consequential events, a factor that was not apparent to the crew as they could not view the primary instruments, or the and alert and notification display. The likely outcome of the diversion to DOH is therefore inconclusive, although the communication and task saturation issues experienced by the remaining pilot would have been negated by a DOH diversion. The communications difficulties with the relay aircraft/BAH-C/EACC/DXB chain of events was the result of the course change toward DXB.

### 2.3.2 Ditching Option

The option to ditch was reviewed during the simulator sessions in Seattle<sup>80</sup>. Although feasible, the inability to see the instruments, particularly the radar altitude or outside of the cockpit window was problematic. The control of the aircraft descent with the AP was another issue that was unresolved.

Attempting to ditch using the auto flight functions was possible, however the last five hundred feet managing the rate of descent, attitude, speed and gauging the sea state in all probability precluded this as an option.

This exercise was inconclusive.

---

<sup>79</sup> Refer to Section 1 – Flight Controls

<sup>80</sup> Refer to Appendix E



## 2.4 Freighter Accident Rate Predictions

---

### 2.4.1 Freighter Airplane Cargo Fire Risk, Benefit and Cost Model

The FAA, Transport Canada, and the UK CAA jointly developed a Risk and Benefit Cost Model to assess the likely number of U.S.-registered freighter fire accidents, and the Benefit Cost Ratio associated with seven mitigation strategies identified by the FAA. The report is structured to explain the data used by the Model Version 5, its algorithms, and the way in which the model may be used.

Model Version 5 is a development of earlier models. Extra functionality has been added and data are now appropriate to the U.S.-registered freighter fleet in 2011.

The model addresses the potential fire threat from all forms of cargo, including that from the bulk shipment of lithium batteries (primary and secondary) since it is considered they are likely to have had a contribution to two of the five freighter fire accidents that have occurred on U.S.-registered airplanes. The model displays the number of accidents through to 2021, and costs, benefits and the benefit cost ratios through to 2026.

The model predicts that the average number of total accidents likely to occur during the next 10 years, 2012 to 2021, if no mitigation action is taken, is approximately 6, ranging from 2 to 12, at 95% percent confidence interval. If no mitigation action is taken, accident costs are likely to average approximately \$50 million (U.S.) per annum over the period 2012 to 2026. The primary contribution to freighter fire accident costs is the value of the airplane – with values of approximately 90% of the total accident cost for the larger freighter airplanes. However, the model predictions of accident costs are based on the assumption that the composition of the U.S.-registered freighter fleet will be largely unchanged from 2011 through 2026 in terms of the size and value of airplanes.

The costs of implementing the proposed mitigation strategies are currently not known to a sufficient level of accuracy to make accurate determinations of benefit cost ratios. However, the model has been constructed to allow user inputs of costs once they become available.<sup>81</sup>

The average number of accidents that might be expected over a given period may be assessed by simply multiplying the revenue ton-miles for the period by the associated accident rate.

For example, the expected number of battery fire accidents over the ten year period 2012 to 2021 would be:

Battery Accident Rate x Battery revenue ton-miles 2012 to 2021

=  $1.99 \times 10^{-9} \times 2,063,769,370$

Approximately equal to 4.1 accidents.

---

<sup>81</sup> The report can be downloaded here: <http://www.fire.tc.faa.gov/pdf/TC-13-2.pdf>  
to download the Model (MS Excel 2007): <http://rgwcherry.co.uk/freighter-airplane-cargo-fire-risk-benefit-and-cost-model-model-version-5-2/>

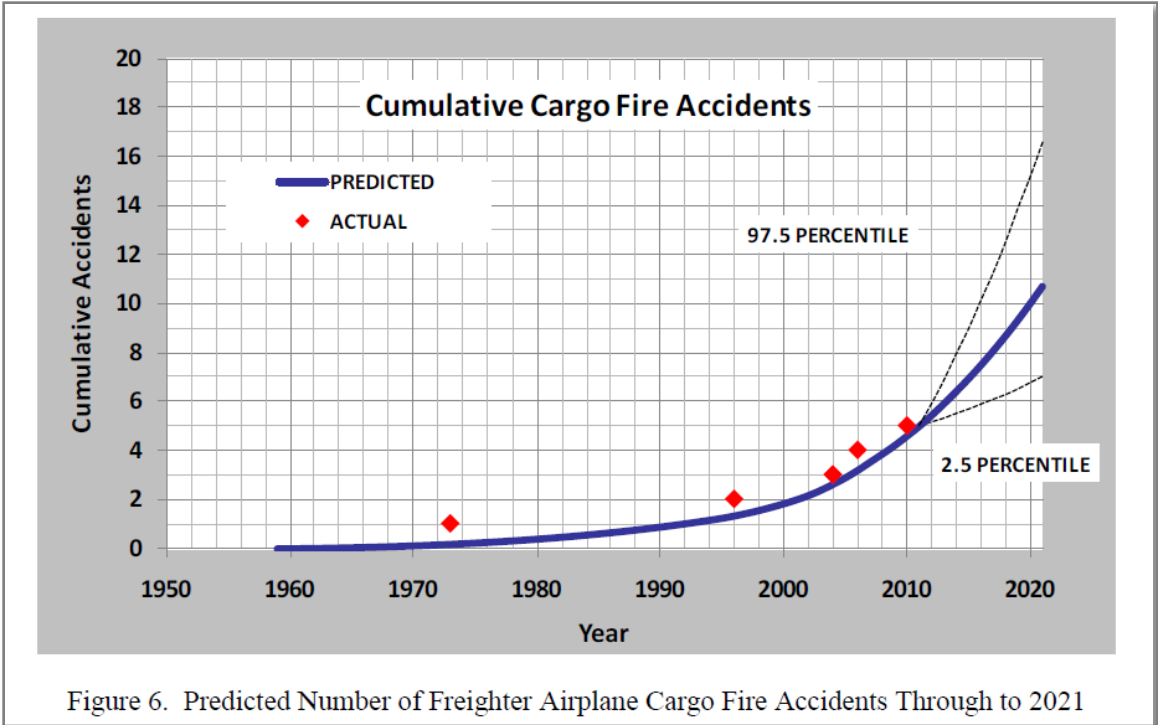

Figure 6. Predicted Number of Freighter Airplane Cargo Fire Accidents Through to 2021

Figure 55 Predicted Number of Freighter Airplane Fire Cargo Accidents Through to 2021

2.5 Determination The Fire Location Using The Aircraft Communications Addressing and Reporting System [ACARS] and the Aircraft Health Monitoring [AHM] Data

As described in the factual information in section one of this report, the Aircraft Communications Addressing and Reporting System [ACARS] transmits operational, maintenance and administrative information between the aircraft and a ground station.

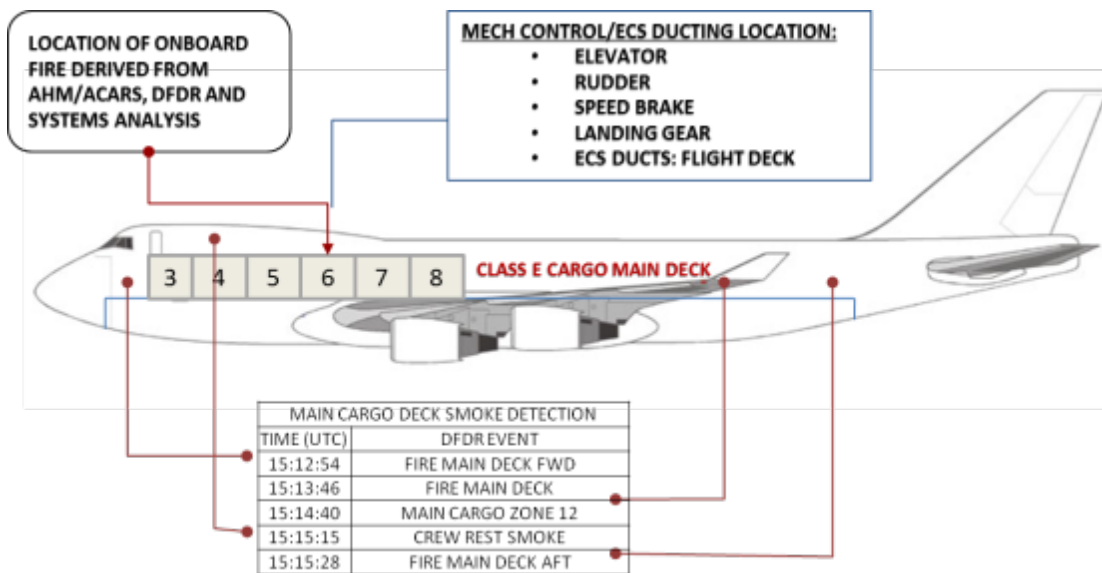

Figure 56 AHM/ACARS Derived Fire Warnings

Below is a interpretation of the ACARS messages from the AHM data received from the accident flight.

The AHM data consists of various ACARS messages received from the aircraft. Broadly speaking these messages can be separated into three categories:

1. RTE reports – Real Time Events. When the Central Maintenance Computer (CMC) receives a faults message from an aircraft system and is able to correlate it to a Flight Deck Effect (FDE) such as an EICAS message, indicator light, etc., an RTE report is initiated by the CMC and sent over ACARS. Each entry described below may include both a fault message and the correlated flight deck effect.
2. On-Condition Reports. The ACARS system is programmed to send reports when certain events occur. These events were defined by the operator and include APU Shutdown report, Take-off Report, and periodic Position Reports.
3. EICAS Synoptic Snapshot displays. On this flight ECS page synoptics were sent from the aircraft in response to request from the ground-based AHM system.

The following ACARS message are arranged in chronological order:

15:14 26314 CARGO FIRE MAIN DECK ZONE-3 LOOP-A FAIL

The Zone 3A detector was in alarm for at least 8 seconds or the 3A detector failed to pass a “disagree” test from the zone 3 AFOLTS card or the wire from the zone 3A detector to the AFOLTS was open circuit when a “disagree” test was performed. Because this fault was corrected to “CGO DET 3 MN DK” and not to “MD CGO 1 LP A”, the Zone 3B detector was in alarm or faulted within 20 seconds of the Zone 3A detector. The above message would be consistent with Zone 3A and Zone 3B detectors being in alarm (detecting smoke) more than 8 second but less than 20 seconds apart.

15:14 26177 CARGO FIRE EXTINGUISHING ARMED Hard Active PACK 2 215 018 00  
ADVISORY

15:14 26177 CARGO FIRE EXTINGUISHING ARMED Hard Active PACK 3 215 020 00  
ADVISORY

The cargo fire extinguishing system was ARMED at 15:14. (This is a step in the “FIRE MAIN DECK” QRH procedure)

15:15 26311 CARGO FIRE MAIN DECK ZONE-1 LOOP-B FAIL Intermittent InactiveCGO  
DET 1 MN DK 261 421 00 STATUS

At 15:15, the Zone 1B detector was in alarm for at least 8 seconds without the Zone 1A detector in alarm, or the 1B detector failed to pass a “disagree” test from the Zone1 AFOLTS card, or the wire from the zone 1B detector to the AFOLTS was an open circuit when a “disagree” test was performed. Because this fault was correlated to “CGO DET 1 MN DK” and not to “MD CGO 1 LP B”, the Zone 1A detector was in alarm or faulted within 20 seconds of the Zone 1B detector. The above message would be consistent with Zone 1A and Zone 1B detectors being in alarm (detecting smoke) more than 8 second but less than 20 seconds apart.

15:15 26313 CARGO FIRE MAIN DECK ZONE-2 LOOP-B FAIL Intermittent InactiveCGO  
DET 2 MN DK 261 422 00 STATUS

At 15:15, the Zone 2B detector was in alarm for at least 8 seconds without the Zone 2A detector in alarm, or the 2B detector failed to pass a “disagree” test from the Zone 2 AFOLTS card, or the wire from the Zone 2B detector to the AFOLTS was open circuit when a “disagree” test was performed. Because

this fault was correlated to “CGO DET 2 MN DK” and not to “MD CGO 2 LP B”, the Zone 2A detector was in alarm or faulted within 20 seconds of the Zone 2B detector. The above message would be consistent with Zone 2A and Zone 2B detectors being in alarm (detecting smoke) more than 8 second but less than 20 seconds apart.

15:15 26315 CARGO FIRE MAIN DECK ZONE-3 LOOP-B FAIL Intermittent InactiveCGO  
 DET 3 MN DK 261 423 00 STATUS

At 15:15, the Zone 3B detector was in alarm for at least 8 seconds without the Zone 3A detector in alarm, or the 3B detector failed to pass a “disagree” test from the Zone 3 AFOLTS card, or the wire from the zone 3B detector to the AFOLTS was open circuit when a “disagree” test was performed. Because this fault was correlated to “CGO DET 3 MN DK” and not to “MD CGO 3 LP B”, the Zone 3A detector was in alarm or faulted within 20 seconds of the Zone 3B detector. The above message would be consistent with Zone 3A and Zone 3BB detectors being in alarm (detecting smoke) more than 8 second but less than 20 seconds apart.

15:15 21015 FLIGHT DECK TRIM AIR MODULATION VALVE/WIRING FAIL V450  
 15:15 21016 UPPER DECK TRIM AIR MODULATION VALVE/WIRING FAIL V451  
 15:15 21071 FORWARD MAIN DECK TEMP SENSOR 2 (AFT)/WIRING FAIL T1925  
 15:15 21072 AFT MAIN DECK TEMP SENSOR 1 (FWD)/WIRING FAIL T1930  
 15:15 21073 AFT MAIN DECK TEMP SENSOR 2 (AFT)/WIRING FAIL T1931  
 15:15 21078 CREW REST TRIM AIR MODULATION VALVE/WIRING FAIL V554  
 15:15 21082 CREW REST DUCT TEMP SENSOR/WIRING FAIL T1937  
 15:15 21083 FORWARD MAIN DECK DUCT TEMP SENSOR/WIRING FAIL T1929  
 15:15 21084 AFT MAIN DECK DUCT TEMP SENSOR/WIRING FAIL T1934  
 15:17 21028 UPPER DECK DUCT TEMP SENSOR/WIRING FAIL T1648  
 15:18 21027 FLIGHT DECK DUCT TEMP SENSOR/WIRING FAIL T1647

The above messages were correlated to both a “TEMP ZONE” advisory and a “ZONE TEMP” status message. (They appear to be listed twice in the AHM report, but may only have occurred once each and were correlated to two different FDE’s.

These messages require additional analysis but currently it appears that these messages indicate faults in the respective components or wiring. One possible explanation would be damage to a common wire bundle near the E2 rack which contains wires for all these components.

These messages were not present in a previous case on another aircraft in which the main deck cargo fire extinguishing system was armed (due to a false alarm).

15:16 35006 SUPERNUMERARY OXYGEN ON Hard Active SUPRNMRY OXY ON 352 109  
 ADVISORY  
 15:16 35006 SUPERNUMERARY OXYGEN ON Hard Active SUPRNMRY OXY ON 352 110  
 STATUS

At 15:16, the Supernumerary oxygen was indicating ON. (This is a step in the “FIRE MAIN DECK” QRH procedure)

15:16 34104 ADF-L RECEIVER FAIL B87  
 15:16 34124 ADF-R RECEIVER FAIL B88  
 15:16 34783 MMR-L FAIL GNSS FUNCTION B10009  
 15:16 34786 MMR-L GNSS RF INPUT FAIL OPEN CIRCUIT

These fault messages pertain to systems which use antennas on the top of the aircraft with coax cables running along the crown.

Note: These messages are not expected to accompany arming of fire extinguishing system but may indicate heat distress to coax cables, other wires or components.

15:17 26164 CARGO AFT-3 LOOP-A FAIL M7902 Intermittent Inactive CARGO DET AFT STATUS

At 15:17, the Lower Lobe Aft Cargo Zone 3A detector was in alarm for at least 8 seconds without the Lower Lobe Aft Cargo Zone 3B detector in alarm, or the 3A detector failed to pass a “disagree” test from the Zone 3 AFOLTS card or the wire from the zone 3A detector to the AFOLTS was open circuit when a “disagree” test was performed.

15:18 22928 MODE OPERATION ERROR (FCC) FCC Code: C243

This fault message may indicate the flight crew overrode the autopilot.

15:19 22504 STABILISER-L/FCC-C FAIL

15:19 22507 STABILISER-R/FCC-C FAIL

Stabiliser position is reported to the FCC’s via wiring that runs along the crown of the aircraft.

Because all of the cargo loop fail messages were logged as Intermittent, the conditions which defined the fail signal must have gone away at least once after the initial setting of the fail signal.

Because all of the cargo loop fail messages were logged as Inactive, the condition which set them to be failed was cleared by the time this AHM data was pulled / sent.

After ARMING the cargo fire suppression system, it was not DISARMED.

After selecting the SUPERNUMERARY OXYGEN ON, the system was not selected OFF.

#### The Analysis Concluded The Following Sequence Of Events Occurred:

- A Main Deck Cargo Fire alarm occurred at 15:13 or 15:14; the Cargo Fire Extinguishing system was armed at 15:14.
- Smoke was detected by in Zones 1A, 1B, 2A, 2B, 3A, and 3B, though not simultaneously. The absence of fault messages from the other zones aft of Zone 3 does not necessarily mean smoke was not detected at in those zones. There are 6 ports for each zone at which air from the main deck cargo compartment is drawn and these ports are plumbed to both the A and B detectors for that zone. Generally there will be the same amount of smoke at the A and B detector of each zone, but there is some variation in each detector at the light obscuration at which the “alarm” is triggered.
- The types of failure modes logged into CMC for these detectors are “failed in alarm” or “failure to provide an alarm when commanded during test.” The fire alarm was provided by the Zone 1 or Zone 2 or Zone 3 smoke detectors, because the cargo fire extinguishing system was armed during the same one minute window that the Zone 3A detector was logged as “failed” but was probably in alarm for at least a short period of time without a Zone 3B detector in alarm. If both A and B detectors in the same zone provide an alarm signal within 8 seconds of each other, there will be no CMC fault message stating that the Zone A or the Zone B detector failed and hence no ACARS report. The alarm could have been triggered by a Zone 1A and a Zone 1B detector in alarm, a Zone 2A and a Zone 2B detector in alarm, or a Zone 3A and a Zone 3B detector in alarm.
- The Zone 1 Loop B fail message indicates that detector 1B was in alarm for 8 seconds without the zone 1A detector in alarm. This could have been because the smoke had just begun building up enough to cause 1B to go into alarm before 1A or both detectors could have been in alarm

and then the smoke changed direction or quantity and the smoke lessened such that 1A went out of alarm at least 8 seconds before detector 1B went out of alarm. The same logic applies to the Zone 2 Loop B fail message.

- The Zone 3 Loop B fail message indicates that detector 3B was in alarm for 8 seconds without the zone 3A detector in alarm. Because we can presume that the zone 3A detector was in alarm earlier, it is most likely that both detectors were in alarm simultaneously for some period of time and then detector 3A went out of alarm at least 8 seconds before detector 3B.
- The Cargo Aft 3 Loop A fail message may have resulted from smoke originating on the main deck entered the aft lower lobe cargo compartment after the aircraft began depressurizing. This is not planned, but is not unexpected.
- During some of the smoke penetration flight tests conducted by the manufacturer, there have been indications that smoke will migrate from the main deck down to the cheeks and from there some smoke has migrated into the lower cargo compartments in sufficient quantity to set off a smoke detector. When the main deck cargo compartment fire suppression system is armed and the DEPR / DISCH button is pressed, the outflow valves are commanded by the Cabin Pressure Controller [CPC] to depressurize the aircraft. The smoke would move aft from the Forward Main deck to the lower lobe cheeks, then on to the outflow valves located at the aft end of the aircraft.

**Conclusion: Based on the ACAR/AHM analysis the cargo fire occurred in Fire Zone 3 at 15:13 UTC**

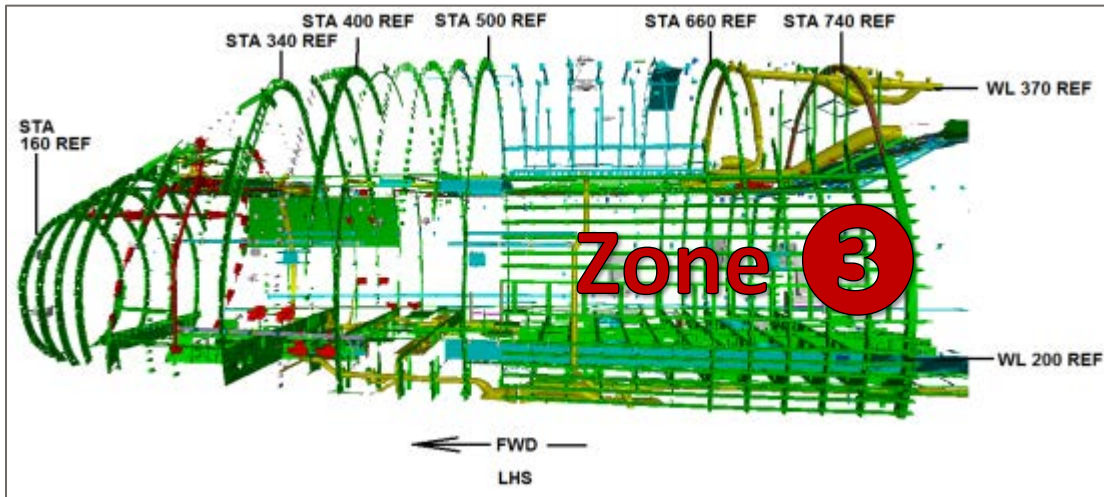

Figure 57- Cutaway Forward Fuselage and Main Deck Cargo Compartment

Zone 3 is approximately defined by the volume between STA 580 and STA 700, where the ceiling begins sloping up at the cargo liner transition point. This immediately below the LH and RH truss assemblies supporting the flight control cables

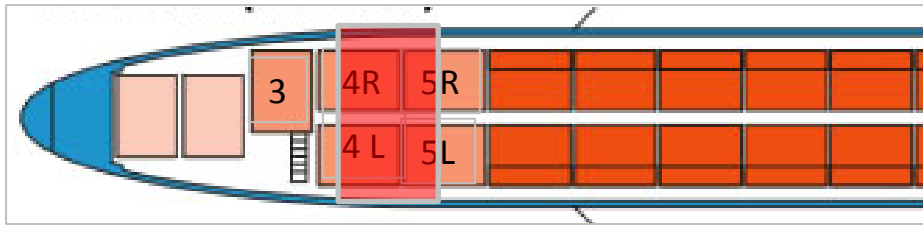

Figure 58 - Pallet Locations/Fire location

Pallet Locations/Fire location

There are pressure relief blowout panels in the ceiling from approximately STA 520 approximately STA 620. The stairs and vestibule are approximately At STA 500.

Fire Zones

As shown in the diagram above, smoke zone 3 encompasses the area occupied by the forward portion of ULD no.'s 5L and 5R, as well as most of ULD no.'s 4L and 4R on the main deck.

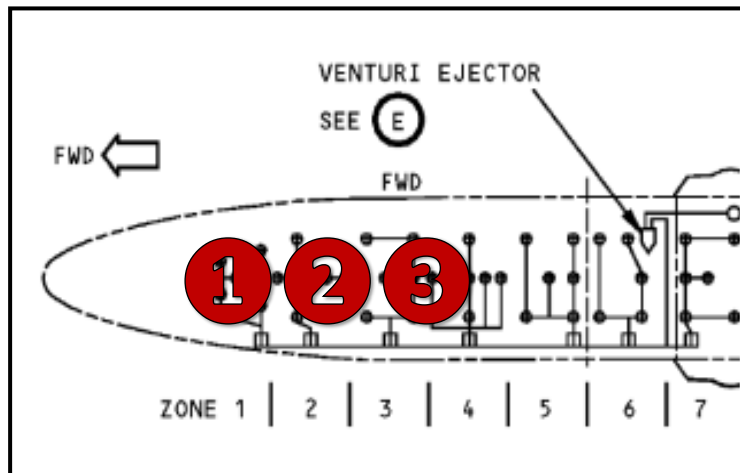

Figure 30 Fire Smoke Detection Zones

Smoke zone 2 encompasses the area occupied by forward portions of the ULDs in positions 4L and 4R, as well as position 3; smoke zone 1 encompasses the area occupied by the ULDs in positions 2 and 1.

2.6 Probable Time of the Pallet Fire Ignition

The time that the fire was detected by the smoke detectors was around 15:13 UTC

According to the NTSB report #DCA10RA0921 - Fire load contribution of lithium and lithium-ion batteries, which includes the pallet fire testing which in the controlled conditions was in an uncontained fire condition at around ten minutes from the initial point of ignition.

Providing the fire rate of acceleration remained constant, it is possible that the fire initial point of ignition was at a point approximately 10-15 minutes prior to the smoke alarm, which establishes the point of ignition in the initial cruise phase.

## 2.7 Source of Ignition and Cargo Fire Sequence

---

As the wreckage was subjected to a large post-accident fire and the aircraft had an on-board fire for approximate 35 minutes prior to the accident, retrieval of evidence was limited to several relatively small pieces of assemblies and components.

It has been established that there were consignments of significant quantities of lithium batteries<sup>82</sup> or derivatives of lithium type batteries on board.

Lithium batteries have a history of thermal runaway and fire, are unstable when damaged and can short circuit if exposed to overcharging, the application of reverse polarity or exposure to high temperature are all potential failure scenarios which can lead to thermal runaway. Once a battery is in thermal runaway, it cannot be extinguished with the types of extinguishing agent used on board aircraft and the potential for auto ignition of adjacent combustible material exists.

Through a process of cross referencing the location of the ACARS fire detection messages and other system indications and anomalies recorded on the FDR, with the cargo manifest for the type, number, location and of the lithium batteries on board, the investigation concludes with reasonable certainty that the location of the fire was in an element of the cargo that contained, among other items, lithium batteries. It is possible that a lithium type battery or batteries, for reasons which cannot be established, went into an energetic failure characterised by thermal runaway and auto ignited starting a chain reaction which spread to the available combustible material



Photo 3- Venting of the electrolyte from a battery exposed to fire.

This can ignite the cargo providing sufficient thermal energy to ignite the adjacent cargo, which included, but did not entirely consist of, lithium batteries.

It is probable that the remaining cargo, the cargo pallet and the adjacent cargo ignited and continued in a sustained state or process of combustion for an indeterminate period of time; the sustained state of combustion in all probability continued up until the aircraft data ceased to record

---

<sup>82</sup> Where 'Lithium Batteries' are referenced in this section, it refers to all types of commercially available lithium battery.



As found in the cargo contain fire testing, particularly in the case of the collapsible DMZ containers, the short time interval between a fire being detectable and peak energy release rate precludes any mitigating action to suppress the fire and protect the aircraft structure. The FAA regulation for cargo compartments certified with smoke detection (14 CFR 25.858) requires a 1 minute detection time from the start of a fire. The regulation does not account for any delay in detection caused by the container. Current certification tests do not use containers. Although 14 CFR 25.858 for cargo compartments certified with smoke detection does not specify any performance metric for what goes on after detection, the results of these fire tests suggest that the intent of the regulation as stipulated in paragraph (b) of 14 CFR 25.858, “the system must be capable of detecting a fire at a temperature significantly below that at which the structural integrity of the aircraft is substantially decreased,” is not being met.

## 2.8 Airconditioning PACK One History

---

The aircraft experienced air conditioning Pack 1 turbine bypass valve (TBV) failure prior to take-off as indicated by the incident flight AHM. Pack 1 continued to operate despite the TBV failure until climb at 10,200 ft, at which time the pack failed off (UTC 14:58:28). The pack failure was likely caused by the inability of the failed TBV to maintain its schedule relative to the ram door positions. This is known as a pack trip, which is confirmed by the “PACK 1 TRIP” CMC fault message under the 14:58 PACK 1 Advisory report in AHM.

The flight crew was able to restore Pack 1 operation at climb 12,200 ft (UTC 15:00:03) by accomplishing a reset per the PACK 1,2,3 non-normal procedure. All three packs were on at the time of the FIRE MAIN DECK indication (UTC 15:13:46). Pack 2 and Pack 3 were then shutoff. This is the expected result of the crew performing the FIRE MAIN DECK non-normal procedure. Pack 1 was the only remaining source of flight deck ventilation per system design. However, FDR indicates that Pack 1 stopped operating at UTC 15:15:21. The shutdown of Pack 1 resulted in loss of all ventilation to the flight deck, which compromised flight deck smoke control. Furthermore, with no packs operating, the Forward Equipment Cooling System automatically reconfigured into the “closed loop” mode, which changed the cooling air to the flight deck instruments from pack air (outside “fresh” air) to recirculated air via the equipment cooling fan. Consequently, any smoke that would have migrated to the E/E Bay would have been drawn into the Forward Equipment Cooling System and supplied to the flight deck instruments.

The system is capable of automatically restoring Pack 3 operation if Pack 1 is detected off. However, this capability does not exist if the Pack 3 selector is in the OFF position. Because the FIRE MAIN DECK non-normal checklist instructed the flight crew to select off Pack 3, it was not able to be automatically restored upon the loss of Pack 1 at UTC 15:15:21. Boeing subsequently revised the crew procedure to eliminate the instructions for selecting off Pack 3.

The AHM and FDR are inconclusive in explaining why Pack 1 stopped operating at UTC 15:15:21. A Pack 1 failure subsequent to the initial PACK 1 TRIP event at 14:58 would have automatically triggered an ECS Air Conditioning Maintenance Page snapshot per the logic in the EICAS software. However, the snapshot would only appear in the AHM report if the criteria for AHM to request the snapshot from EICAS had been met. In this case the criteria were not met because PACK 1 TRIP CMC message had already gone "Intermittent" per the last RTE report at 14:58. Once a message becomes Intermittent, CMC will not trigger a snapshot request if a subsequent occurrence of that fault is detected.

## 2.9 Cargo Compartment Liner Certification Deficiencies

---

### 2.9.1 Cargo compartment Liner Damage Tolerance

Two issues characterize the cargo compartment liner limitations in the event of a large sustained uncontrolled fire:

- i. The flame exposure mechanical strength of the fiberglass over time
- ii. The aluminum structure that the liner is attached remaining capable of sustaining the liner load and/or remaining in position

The liners are attached to the aluminium airframe structure, with heat release rates similar to the NTSB container tests, based on engineering judgment, the aluminium supporting the liners would fail if the liners have been damaged. Unsecured, the liners would collapse, exposing the area above to further fire damage and further thermal loading, compounding the heat exposure and damage tolerance aspects.

The fire test is a static test under controlled conditions designed to test a sample of the liner. The reality of a cargo fire of the scope experienced by the crew of the accident aircraft is that there are several additional factors influencing the capability of the cargo compartment liner: there are potentially ballistic, acoustic and airframe vibration issues to determine as the mechanical static strength of the liner is not covered in the damage tolerance considerations. The certification for the design failure case for Class E cargo compartments should consider the requirement for a catastrophic single point of failure.

Reviewing the fire behaviour and the normal onboard environment of a large cargo aircraft, the cargo compartment liner certification is not addressing the total risk.

The test method to determine flame penetration resistance of cargo compartment liners, based on the NTSB fire testing, the cargo compartment liner structure to be effective should be subjected to extreme heat and other input loads such as vibration, multi-axial loading, intermittent pressure pulses, thermo mechanical loadings based on differential materials coefficients, acoustic and ballistic damage.

For ceiling liners the resulting degradation in the structural integrity of polymer matrix structures when subjected combined extreme heat and vibration is not a certification requirement as the cargo compartment liner is assumed to remain intact.

The material degradation represented by severe thermal loading can cause the instantaneous decrease in stiffness and strength properties of the cargo compartment liner material, in particular, the failure under combined thermal and mechanical loads when subjected to applied uniaxial stress and high heat flux/thermal loading.

Currently a universal fire protection certification standard covers all transport category aircraft.

Although these regulations limit the flammability of construction materials used in cargo compartments and also specify minimum fire resistance requirements for cargo compartment liners, there is limited regulation concerning fire protection associated with cargo containers.

## 2.10 Fire Suppression Methodology – Climb or Descend to 25,000 ft

---

There is no requirement for dedicated fire suppression in large transport aircraft. The manufacturer uses 25,000 ft as the optimum altitude to prevent combustion. The fire suppression strategy in aircraft main deck cargo compartments is based on oxygen deprivation and fire resistant materials.

No active fire suppression is required by the FAA or EASA for class E cargo compartments

Based on discussions with the manufacturer the following information was obtained regarding the 25,000 feet for Class E cargo compartment fire reasoning for this aircraft type:

1. Aircraft depressurization is not required as per the regulations applicable to Class E cargo compartments, it is an industry and regulatory accepted method of providing additional fire protection to aircraft equipped with Class E cargo compartments.
2. The manufacturer selected the altitude of 25,000 feet for Class E cargo compartment fire fighting altitude as optimal based on studies of the National Fire Protection Association (NFPA), FAA and other literature available. NFPA data indicates the minimum re-ignition energy varies inversely with the square of the pressure and concludes that approximately four times the ignition energy is required to rekindle a fire at 25,000 feet vs. that of 5,000 feet. In addition, FAA experimental fire test data, conducted on ground simulating altitude environments (5K to 25K feet) suggests when the available oxygen quantity is reduced a fire can be effectively suppressed.
3. In establishing the FL250 diversion altitude, the manufacturer also assessed other factors such as flight crew physiological tolerance (e.g. Decompression Sickness, and Hypoxia), crew oxygen, terrain clearance and determined 25,000 feet is acceptable based on the available data.
4. As Class E cargo compartments are not required to be equipped with fire detectors [such as an infrared camera or thermal detector<sup>83</sup>] but with smoke detectors, the fire detection is directly related to the rate and volume of smoke detected by the smoke detectors.

Main deck cargo compartments on ICAO class E/F aircraft are large and fires can develop before any passive suppression due to oxygen deprivation can help slow down the fire.

For example, in this accident, the time interval between fire detection and the onset of aircraft system failures was about 2 minutes 30 seconds. The crew attempted to depressurize the aircraft to slow down the fire 30 seconds after the loss of aircraft systems and flight controls.

Additionally, experiments performed at the FAA's William J. Hughes Technical Center in Atlantic City, New Jersey have shown that, although depressurization can suppress flaming combustion, the fire continues to propagate, increasing overall compartment temperatures and pyrolyzing fuel such that upon the reintroduction of oxygen (for example, as the aircraft descends for landing), the fire resumes at an even greater intensity.<sup>84</sup> Experience from this accident investigation in conjunction with FAA experiments suggest passive fire suppression in large cargo compartments due to oxygen deprivation may not be effective.

The addition of oxygen from the crews' damaged supplementary oxygen system venting directly into the fire in the cargo compartment environment - the introduction of oxygen can directly contribute to the sustaining and propagation of a fire event.

---

<sup>83</sup> GCAA comment inserted for clarity

<sup>84</sup> [http://www.fire.tc.faa.gov/2010Conference/files/Cargo\\_Fire/HillDepressurizationFreighter/HillDepressurizationFreighterPres.pdf](http://www.fire.tc.faa.gov/2010Conference/files/Cargo_Fire/HillDepressurizationFreighter/HillDepressurizationFreighterPres.pdf)

Based on the cargo container and pallet trials it has been established that the time it takes for a fire detection system to detect a fire originating within a cargo container with a rain cover may easily exceed the one minute time frame specified in USA/Title 14 Code of Federal Regulations (CFR) 25.858(a).

The fire detection system detects fire by sampling the cabin air for smoke only. There is no active fire detection system required which can identify heat or ongoing pyrolysis.

The fire suppression methodology of venting airflow and depressurisation of the cargo hold is a passive system of fire suppression which works through controlling the available oxygen to a conventional fire with the presumed effect of cancelling the fire triangle, preventing or inerting further combustion.

One other factor for the 25,000 ft limit is that when the fire suppression depressurisation is activated, the avionics bay vents are in reduced flow, affecting the avionics bay cooling.

The manufacturer and the operators fire suppression methodology is based on suppressing a conventional fire where the normal fire triangle operates, not a class D metal fire where a sustained exothermic reaction not ambient oxygen dependent is in the process.

Class D fires are caused by burning metals that combust easily on contact with air, such as magnesium and lithium. Either powder extinguishers are required or a method of cooling the metal below auto ignition temperatures.

The current regulatory framework and the practical requirements for extinguishing large cargo fires are unsynchronised regarding the requirement of the regulation and the intention of fire suppression.

## 2.11 Single Point of Failure Analysis [SPoF]

---

The risk associated with the current cargo fire potential is that the carriage of standard cargo consignments can expose the cargo compartment liner to a fire or thermal load that exceeds the certification design requirements.

The single point of failure in this accident was the inability of the cargo compartment liner to prevent the fire and smoke penetration of the area above pallet locations in main deck fire zone 3.

This resulted in severe damage to the aircraft control and crew survivability systems, resulting in numerous cascading failures.<sup>85</sup>

As the cargo compartment liner failed, the thermal energy available was immediately affecting the systems above the fire location: this included the control assembly trusses, the oxygen system, the ECS ducting and the habitable area above the fire in the supernumerary compartment and in the cockpit.

The consequential effects of the continuous smoke and heat penetration on the cockpit environment are covered in detail in various sections of this report.

---

<sup>85</sup> The failure of a system due to the failure of another is known as cascading due to the effect as the failures occur in a sequence

## 2.12 Emergency Flight Management

### 2.12.1 Procedure and Methodology

For crews operating large transport category aircraft in the dedicated freighter role, where there are large Class E cargo compartments, such as this accident aircraft, there is the potential with the checklist to inadvertently accentuate the fire problem.

The accident flights NNC is below. After completing the vital actions to control the fire, the crew are given the instruction:

- Step 7 - *Climb or descend to 25,000 feet when conditions and terrain allow*
- Step 8 - *Plan to land at the nearest suitable airport*

These two steps are analogous to recovering the aircraft, however, based on the fire suppression methodology they are contradictory in their intent.

**BOEING** 8.19  
747 Flight Crew Operations Manual

**MAIN DECK** **FIRE MAIN DECK**  
**FIRE MN DK AFT, FWD, MID**

Condition: Smoke is detected in the main deck cargo area(s).

- 1 Don the oxygen masks.
- 2 Establish crew communications.
- 3 SUPRNMR Y OXY switch . . . . . ON
- 4 MAIN Deck CARGO FIRE  
ARM switch . . . . . Confirm . . . . . ARMED  
N570UP - N579UP  
SATCOM will shut down to prevent overheating.  
System shuts down two packs and respective  
PACK EICAS messages are shown.
- 5  PACK control selectors . . . . . Two packs off
- 6 CARGO FIRE  
DEPRES/DISCH switch . . . . . Push and  
hold for one second
- 7 Climb or descend to 25,000 feet when conditions  
and terrain allow.
- 8 Plan to land at the nearest suitable airport.

Figure 59 Fire Main Deck Non Normal Checklist

A fire in a sustained state of combustion will continue to burn or increase the rate of pyrolysis compounding the fire and smoke problem. If the fire has been temporarily suppressed, it will, based on the NFPA data on the inverse square rule for minimum re-ignition, begin to reignite on descent.

The checklist instructs the crew to remain at 25,000' or land. The contradiction between the requirement to maintain 25,000 ft to control a fire and the requirement to descend and land at the nearest suitable or available airfield is not resolved in the checklist methodology.

## 2.12.2 Non-Normal Checklist Crew Advisory and Fire Suppression Methodology

Absent from the fire checklist are the intermediate steps to assess the fire condition prior to initiating a descent, factors to consider should include the following:

- Is the cargo in a state of sustained combustion?
- Has the suppression worked?
- Is the safety of the crew at risk
- What is the airworthiness of the aircraft?
- When is it safe to descend?

To safely descend without additional risk, the current checklist requires the crew to make a judgement on the condition of the fire, without providing the crew with the means to accomplish the task.

This requires evaluating the risk of descending if the available combustibles on board are sufficient for reigniting the fire<sup>86</sup>

The QRH Fire Main Deck checklist does not address the key factor of descend or divert decision making if there is a large scale cargo fire.

The checklist fire suppression methodology advises the crew to remain at 25,000 cabin pressure altitude to suppress a fire or land at nearest suitable airport. It does not provide guidance for when or how to transition to landing or the fact that descending early might provide more atmospheric oxygen to the fire. There is no intermediate step to verify or otherwise assess the condition of the fire and to evaluate the risk to the aircraft if a descent is initiated.

The descent from 25,000' will cancel the available passive fire suppression with the potential for re-ignition due to the availability of ambient oxygen, which will further exacerbate the fire/smoke problem, with the possibility of causing the latent fires remaining in the cargo to re-ignite.

The potential for this level of risk in large cargo aircraft is not addressed in the State of Manufactures certification procedures or the manufacturers or aircraft operators methodology concerning in-flight fire risk mitigation.

There is no system or risk methodology available to a cargo crew to recognise when a fire is sufficiently suppressed to stop combustion and at what point in an emergency it is safe to descend.

In the case of this accident, the descent to 10,000 feet at the start of the return to Dubai may have contributed to the rate and volume of smoke produced.

Without active fire suppression and a method to determine if a fire is sufficiently extinguished, the decision to descend from 25,000 feet could potentially directly contribute to the problem of fire propagation and smoke generation combined with a risk to the critical systems and the eventual outcome of the flight.

Diversion, Descent and Landing Guidance<sup>87</sup>

Currently SFF checklist methodology concerns whether or not crews should be given guidance to divert and where in the checklist this guidance should appear.

---

<sup>86</sup> Refer to the inverse square rule used to determine the ignition energy requirements

<sup>87</sup> Do You Smell Smoke? Issues in the Design and Content of Checklists for Smoke, Fire, and Fumes Barbara K. Burian, Ph.D./SJSUF at NASA Ames Research Center/ Emergency and Abnormal Situations Study in the Human Factors Research and Technology Division at NASA Ames Research Center.

In many current non alerted SFF checklists, guidance to complete a diversion and/or emergency landing is given as one of the last steps, if it is given at all, and the guidance to complete such a diversion is only pertinent if efforts to extinguish the SFF were unsuccessful.

In the absence of active fire suppression the philosophy implicit in this design is that continued flight to a planned destination is acceptable if in-flight smoke or fire is extinguished.

If crews follow these types of checklists exactly as written, a diversion is initiated only after the completion of steps related to other actions, such as crew protection (i.e., donning of oxygen masks and goggles), establishing communication, source identification and troubleshooting, source isolation and firefighting, and smoke removal, and then only if the SFF is continuing.

A study conducted by the Transportation Safety Board of Canada, in which 15 in-flight fires between 1967 and 1998 were investigated, revealed that the average elapsed time between the discovery of an in-flight fire and the aircraft ditched, conducted a forced landing, or crashed ranged between 5 and 35 minutes, average landing of the aircraft is 17 minutes.

Two other B747 Freighter accidents caused by main deck cargo fires have similar time of detection to time of loss of the aircraft time frames, South African Airways Flight 295 was 19 minutes before loss of contact and Asiana Airlines Flight 991 was eight minutes. Both aircraft had cargo that ignited in the aft of the main deck cargo compartment.

The accident aircraft in this case, was 28 minutes from the time of detection until loss of control in flight. The cargo that ignited was in the forward section of the main deck cargo compartment.

The average time is seventeen minutes. This should be factored into the fire checklist that an immediate landing should be announced, planned, organised and executed without delay.

These findings indicate that crews may have a limited time to complete various checklist actions before an emergency landing needs to be completed and the checklist guidance to initiate such a diversion should be provided and should appear early in a checklist sequence.

## 2.13 Smoke Penetration – Upper Deck Cockpit and Supernumerary Area

### Smoke/Fumes Barriers

The accident aircraft was not required to be equipped with a cockpit door or screen.

When the cargo compartment liner was breached, the smoke penetration into the rear of the supernumerary area was unavoidable.

This type of aircraft is exempt from the cockpit door requirements [according to CFR 121].

### Smoke Density/Soot Deposits

In the absence of any recording systems to verify the smoke density it is possible using an established evidence reference data to gauge the smoke density by observing the level of deposited material on surface area or objects ejected from fire zone 1<sup>88</sup> in the debris field, or clear of the fire zones in all debris fields.

---

<sup>88</sup> Do not confuse these fire zones with the onboard fire zone demarcations on the main cargo deck.

Using the Ringelmann scale<sup>89</sup> to compare the deposited residue on the retrieved components from parts of assemblies recovered from the supernumerary area, the Ringelmann scale value were between #4/80% and #5/100%.

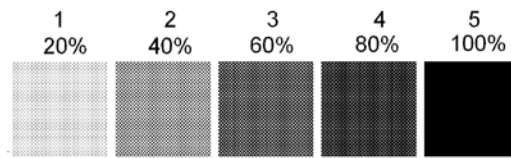

Figure 60 - The Ringelmann Scale: The smoke composition and density scale

#### Smoke and Toxic/Noxious Gases

The unsafe condition of continuous, unstoppable smoke entering and accumulating in the cockpit was a contributing cause to the incapacitation of the Captain following the mask removal when the oxygen flow had stopped. Controlling the smoke penetration is a crew survivability issue.

### 2.14 Smoke and Reduced Cockpit Visibility

---

The lack of verifiable CRM data lead to the investigation team establishing a quantified test and validation exercise using a B747-400 Simulator.<sup>90</sup>

The testing was devised by an NTSB behavioural scientist, who observed, recorded and analysed the data and simulator crew performance.

The objective were to run simulations of the scenarios encountered by the accident crew to establish definitive baseline CRM data on communications, checklists, handling and auto flight conditions

A report on the exercise is contained in the appendix . The exercise concluded:

- It is imperative that when cockpit visual clarity is compromised, clear and defined task and role differentiation between the PF and PM are understood and reinforced through adequate training.
- Crews should be very familiar with the functioning of the oxygen mask selectors and the switching options, including the mask venting function.
- Turning off the dome light aids text differentiation in smoke + twilight conditions.
- EICAS messages that cannot be read are a fundamental flaw in the smoke filled cockpit checklist design philosophy.
- Reversion to a variation of single pilot operation appears to be a standard reaction to a lack of communication in multi crew operating environments. It would be advisable that if a crew member goes into a single pilot operation state of cognitive functioning, that the actions performed are enunciated (as per normal) to provide a clue to the PM, or non-handling pilot, that a command decision has been made and the PM should revert to a passive or supernumerary role.
- Training for worst case scenario emergency flight management should be predicated on the requirement to perform an immediate landing with degraded cockpit visibility and

---

<sup>89</sup> The Ringelmann scale is a scale for measuring the apparent density of smoke and fire levels of density inferred from a grid of black lines on a white surface

<sup>90</sup> Refer to the Appendices for the full test report



communications. This should be a rehearsed procedure with the decision points clearly established through repetitive training.

- Checklists should be fully representative of the reality of the emergency they are attempting to mitigate.

## 2.15 Pilot Incapacitation

---

The incapacitation of the Captain early in the event sequence was a significant factor in the investigation. Based on the elevated temperature testing results and incidental CVR comments, it is now understood why the oxygen flow stopped after the PVC hose connector had failed, the direct effect of this failure on the crew survivability and subsequent events in the accident timeline.

At 15:19:15, the Captain says 'it's getting hot in here', at 15:19:56 there is the first indication that the Captains oxygen supply was compromised.

The Captain's incapacitation was possibly preventable as there was additional supplemental oxygen available in the aft of the cockpit area and in the supernumerary area. The Captain requested oxygen from the F.O. several times over approximately one minute. The First Officer due to possible task saturation was either not aware of the location of the supplementary oxygen bottles or able to assist the Captain. It is not known if the Captain located either of the oxygen bottles although they were within 2 meters of the Captains position.

The Captain removed the oxygen mask and separate smoke goggles and left the seat to look for the supplementary oxygen. The Captain did not return. The Captain was in distress locating the supplementary oxygen bottle and could not locate it before being overcome by the fumes. The Captain was incapacitated for the remainder of the flight. A post-mortem examination of the Captain indicated that the cause of death was due to carbon monoxide inhalation.

The F.O had limited time on type and eight minutes into the emergency was in a single pilot environment having to manage a smoke compromised cockpit environment and numerous cascading failures.

The protection of critical systems for two crew flights should be reviewed in conjunction with the operator modifying their training system to advise the practicalities of locating the alternative supplies and single crew CRM operating procedures.

The key to avoiding serious problems from the incapacitation of one pilot in a multi crew aircraft is the availability of appropriate SOPs and recurrent training which encourages their use if necessary.

## 2.16 Access to Cockpit Emergency Equipment from the Pilot Seated Position

---

A cockpit ergonomics and accessibility exercise in a Boeing Converted Freighter (BCF<sup>91</sup>) aircraft was conducted to determine the access to the cockpit emergency equipment from the pilots seat.

- The cabinet housing the emergency equipment was located on the left side of the cockpit, behind the left jump seat, and was placarded with 'Halon/Portable O<sub>2</sub>/Crash Axe only'. However, also located in the cabinet was a harness for use when evacuating an incapacitated crewmember and a life vest which were placed on top of the O<sub>2</sub> bottle.
- The oxygen mask hose length measured 56 inches from the captain's panel to the oxygen mask.
- The pilot was not able to access the jumpseat oxygen mask when seated and the seat was forward. The distance between the pilot's fingertips and the mask was 5 inches.
- The pilot was able to access the left jumpseat oxygen mask when the seat was full back and he reached over the back of the seat. He was not able to fully grab the mask from the housing but his fingertips were able to grab the hose and pull it out.
- The pilot would not be able to fly from the left seat when wearing the left jumpseat oxygen mask.
- It took the pilot 16.5 seconds to stand from the left seat, reach for left jumpseat oxygen mask, remove the left seat oxygen mask, don the jumpseat oxygen mask, and reach the cabinet with the emergency equipment.
- The fire extinguisher was mounted upright on the cabinet's left sidewall. The portable oxygen bottle was mounted to the floor of the cabinet. To remove the portable oxygen bottle, the pilot first had to remove the fire extinguisher from the cabinet.
- The pilot could not remove the portable O<sub>2</sub> bottle without first removing the Halon bottle due to the proximity of the left rear jumpseat backing. However, the layout of the portable oxygen bottle and extinguisher differs between the BCF and the B747-400F.

The conclusions are that the oxygen locations are not obvious unless a person is specifically trained on the aircraft, they are cluttered and or have obstructions in the design of the arrangements and that the pilot, when sitting cannot access the alternate oxygen masks.

### Access to Emergency Equipment

An ergonomic assessment of the differing oxygen locations was conducted, including from the LH observers seat directly aft of the Captains seat.

The location of the portable cockpit O<sub>2</sub> bottle with a full facemask is located directly to the left of the observer's seat, obscured and cluttered. Full details are contained in Appendix J.

---

<sup>91</sup> The UPS BCF aircraft are differently configured than the UPS 747-400 Freighter (the accident aircraft), but the relative locations and distances between the captain's seat, left jumpseat oxygen mask, and the emergency oxygen bottle closely correspond to those on the Freighters.

## 2.17 Recording Devices - Visual

---

The absence of image recording devices in several high profile air accident investigations over the previous twenty years has resulted in the safety authorities concerned issuing recommendations for the compulsory installation of image recording devices to assist the investigation with understanding what was occurring in and around the cockpit area.

It is anachronous given the complexity of the modern aviation environment that accident investigators are required to derive the cockpit environment through a process of acoustic investigation using the CVR, analysing the DFDR data and ATC communication to build a comprehensive model of the cockpit environment when there exists a method to observe the flight deck behaviour and vital actions, the flight control positioning, through the installation of recording devices which can record images, either static time lapse, or constant recording. Recently it has become economically realistic to record cockpit images in a crash-protected memory device, with digital playback and crash protection as for the CVR.

The deductive and analytical investigation process consumed several hundred hours of investigative resources. The majority of the time was expended determining the cockpit environment; this slowed down the investigation and narrowing down the factual data could have affected the speed and delivery of the safety recommendations.

With a digital playback image recorder available to the investigation of the cockpit environment the investigation could have been expedited and potential safety actions more easily identified.

The cockpit was not equipped with an image recording device as this type of device is not required by the current regulations. Several Transportation Safety Boards and Accident Investigation Sectors have recommended devices to record cockpit images.

Regulations do not require the recording of cockpit images, although it is technically feasible to do so in a crash-protected manner. Confirmation of information, such as flight instrument indications, switch position status, and aircraft system degradation, could not be completed without this information.

## 2.18 PHMSA/HMR/ICAO Technical Instructions

---

The current HMR for domestic air cargo transport continue to allow many small lithium batteries to be transported as general cargo without the safety precautions that are provided for other common hazardous materials. Under current regulations, certain shipments of small batteries are exempt from hazardous materials packaging and identification requirements. These exemptions potentially permit large quantities of unidentified small lithium battery shipments on board both cargo and passenger aircraft, while the revised ICAO Technical Instructions substantially reduce the sizes of small lithium batteries that are subject to regulation. Lithium battery shipments in aircraft are increasing in number, and batteries are increasing in energy density. Recent incidents and research continue to show that lithium battery failures (regardless of the source or cause) can release flammable electrolyte or result in violent, high-temperature reactions that can ignite combustible or flammable material nearby or further fuel an existing fire.

The PHMSA final rule<sup>92</sup> incorporated the ICAO Technical Instructions by reference, thus permitting, but not mandating, domestic lithium battery shipments to be transported by air in accordance with the international standards (except where the HMR prohibit primary lithium batteries and unapproved prototype lithium batteries and cells aboard passenger-carrying aircraft). The ICAO Technical

---

<sup>92</sup> See FR 78, no. 4 (January 7, 2013): 988.

Instructions increased restrictions for shipment of lithium batteries by significantly decreasing the excepted quantity permitted in international cargo shipments. If the HMR are harmonized with the ICAO Technical Instructions, a significantly larger number of fully regulated domestic air cargo shipments of lithium batteries would be subject to the greater level of safety provided by specification packaging requirements and United Nations safety testing, labelling, and hazard communication standards. Complying with such increased safety requirements and standards would reduce the risks associated with transporting these materials.

Note: Several package level mitigation procedures are available that will contain the battery thermal energy and prevent the spread of fire to adjacent material

The current standards regarding package level protection should be increased and enforced through regulation.

## 2.19 Protection of Critical Systems

---

Several aspects of the investigation centred around the CVR statements from the crew concerning the rate and volume of continuous smoke or fumes entering the cockpit area and the increasing temperatures in the cockpit area.

The protection of critical systems for the area above the class E cargo compartment is predicated on the cargo liner remaining intact as a physical and as a thermal barrier.

Cargo compartment liner testing/specifications and failure prediction of the design criteria for glass fiber cargo compartment liners under fire degradation does not include the material degradation under sustained thermal/mechanical loading.

Fibre-reinforced plastic (FRP) is a composite material made of a polymer matrix reinforced with fibres can be severely degraded/damaged under thermal loading due to exposure fire.

Certification standards should consider the development of a quantitative framework for assessing the degradation of polymer matrix properties and the resulting degradation in the structural integrity of polymer matrix structures when subjected to extreme heat and vibration.

The material degradation of the liner can be evidenced as the instantaneous decrease in stiffness and strength properties at the temperatures in question during a large sustained cargo fire.

An integrated experimental approach aimed at developing a quantitative methodology for assessing the structural integrity of polymer matrix structures subject to severe thermal loads caused by fire is an approach recommended to the airworthiness authorities by the investigation team.

This approach involves modelling composite material degradation due to fire loads and developing an analytical methodology to describe the loss in load bearing capacity (i.e. structural integrity) of the cargo compartment liner structures. In particular, the failure under combined thermal and mechanical loads. The approach has been based on the notion of failure surfaces which are plots of the time-to-failure of loaded panels versus the applied uniaxial stress and the incident heat flux.

Empirical data was obtained on the temperature dependence of basic mechanical properties such as tensile stiffness and strength along with shear strength. This data indicates degradation behaviour due to exposure fire.

Data would also be useful to calibrate thermo-mechanical loadings to develop a realistic failure case for combined high thermal and multi-axial loading for cargo compartment liners under the current certification standard.

## Supplemental Oxygen System

Failure of the fire protection [cargo] liner to limit the exposure of the Supplemental Oxygen System [SOS] to the extreme thermal loading was a contributing factor to the disruption of the oxygen flow to both crew members.

### 2.20 CVR Sound Spectrum – Determining The Oxygen Mask Settings

The Cockpit Voice Recorder (CVR) Group for this investigation noted that both crewmembers had some unidentified issues with the crew oxygen system. The CVR indicated that during pre-flight, the crew accomplished completing the oxygen check, which on the B747-400 AOM indicates that the masks are stowed, flag is out of view, and Normal/100% switch is set to 100%. Both crew had donned their oxygen masks approximately 1.5 minutes after the fire bell sounded. About 5.5 minutes later, the Captain indicated that he was out of oxygen, and his breathing sounds (as captured by the oxygen mask microphone) ceased. About 2 minutes later, the First Officer's breathing sounds stopped for about 20 seconds. About 20 seconds later the First Officer said "I'm looking for some oxygen" during a radio transmission. Shortly thereafter, his breathing sounds stopped again for about 20 seconds. After this, his breathing sounds can be heard until the end of the recording (about 20 minutes later). However, about 10 minutes before the end of the recording, the First Officer transmitted "...we are running out of oxygen."

In order to better understand how the oxygen system was being used (i.e. the mask configuration of "normal" vs. "100%", the "Emergency" setting, and the smoke vent setting), a flight test was conducted using oxygen masks of the same make/model as was installed on N571UP. The masks were operated in flight and on the ground, using all possible configuration settings. During these tests, the audio from the mask microphones and the cockpit area microphone was captured by the aircraft's CVR, and used for comparison with the audio from the accident flight.

The results of this study indicate that the sound spectrum data from the accident flight is consistent with the following:

- Captain's mask setting: 100 %
- First Officer's mask setting: Normal
- Neither mask appears to be in the 'Emergency' mode
- The smoke vent condition (open or closed) could not be determined for either mask

The details of the study are included in the Appendix

### 2.21 Crew Training – Smoke, Fire, Fumes

Serious in-flight emergencies are uncommon events, particularly an in-flight emergency of the scale experienced the crew of this Boeing 747-4AF.

Evident in the cockpit analysis is confusion due to the smoke and visibility problems as the crew managed the deteriorating cockpit environment as the aircraft was not responding to the crews attempts to control the abnormal situation.

The sequential failure of the aircraft systems, in conjunction with the deteriorating cockpit environment and consequential incapacitation of the Captain in conjunction with the complicated and confused CRM environment are not events that can be trained for with any degree of realism.

Elements of these emergency factors are practices in isolation, for example smoke in the cockpit evacuation, crew incapacitation and multiple systems failure.

A completely obscured smoke/fumes cockpit is a unique environment, simultaneously rendering normal cockpit management problematic is predicated on the ability to view and communicate in the limited living space of an aircraft cockpit, into a confusing and non-synchronous situation where valuable time is used to perform normal cockpit functions. This can be a distraction from the problem solving required to effectively manage a developing series of emergency actions or tasks.

The training environment for non-normal and emergency training procedures for large freighter aircraft is not realistic concerning the risk and crew mitigation options with continuous smoke in the cockpit. Specialised risk based training in fixed ground training devices could be an advantage to prepare crews to manage the problems associated with continuous smoke filled cockpit environments.

Other examples of this type of environment exist in aviation, for example off shore rotary operations require crew training in a crew simulator that can be submerged in water, rotated 180° and also be used in conditions of low light: these are the realistic emergency conditions which an off shore crew could experience and the simulator is used to provide a real time exercise that provides the crew with instinctive cognitive reactions, which due to the limited human endurance when submerged [approx. 180 seconds without exertion], can be the difference between a successful or unsuccessful cockpit egress.

This type of emergency training approach should apply to dedicated aerial freighter operations, in particular with the unique three level architecture of the B747-400F series of aircraft, with the cockpit position directly above a main cargo deck.

Based on a derived cockpit environment analysis, there are several safety lessons to be learned and communicated to the aviation industry.

Simulator training today largely focuses on how to fly the aircraft and how to respond to an emergency. It has not progressed to a fully 'evidence based' training in which we use objective flight data to develop training scenarios from known accidents, incidents and FOQA events, factoring these into recurrent training processes.<sup>93</sup>

A safety enhancement would be the adaption by cargo dedicated transport companies to have a separate smoke/fire/fumes immersion training device, where crews can experience the limitations of a completely smoke filled environment, with the attendant CRM difficulties of donning oxygen mask, reading checklists in low visibility, establishing communications and the reality of functioning in an emergency situation, where problems of visibility and managing the aircraft can be experienced, awareness increased and mitigation strategies developed at a crew operating level.

## 2.22 Computer Model Thermal Analysis of a Container Fire in a Class E Cargo Compartment

---

A detailed thermal model was proposed by the manufacturer to conduct a thermal analysis of the effect of an uncontained fire. It was problematic to devise a realistic scenario due to the large number of variables associated with each specific model proposed.

The CAD thermal model developed by the manufacturer of the aircraft assumed the following:

---

<sup>93</sup> ICAO Document 9995 - Manual of Evidence Based Training is available for referencing the EBT requirements as derived by ICAO.

- There is no flow through duct
- Fire load:
  - Located in pallet position 6R where the AMJ container of interest was located on this flight
  - Top edge of fire is aligned with top edge of AMJ container
  - Does not extend all the way to the floor solely for modelling convenience. Hence it appears to “float” in cargo bay.
  - Does not fill the AMJ container. Simply loaded the container with the 3 x 2 x 3 (height x width x depth) of 18 inch square boxes.

The thermal model assumes the cargo compartment liner remains intact. This model indicates that the temperature at the cargo compartment liner can reach a temperature between 1460F-approaching 1800F. The certification standard, supported by the empirical testing conducted by the FAA supports the assumption that if the cargo compartment liner remains intact, that temperatures provide no identified hazard to the surrounding structure. This thermal load condition is a static assumption without factoring aircraft movement, vibration or ballistic interference with the cargo compartment liner.

Based on experience, after prolonged exposure to a high, consistent thermal loading, very little mechanical strength remains in the material, the glass is very brittle and if subjected to vibration, movement, projectiles, etc., it can easily break apart.

A thermal model that assumed the cargo compartment liner remains intact was not considered viable given the accident findings.

## 2.23 Communications

---

The smoke in the cockpit presented several problems to the PF. The communication difficulties between the aircraft, the fixed ground stations and the relays were contributing factors in this accident.

The communication difficulties based on the frequency selection could have been reduced had the PF been able to communicate on the guard frequency direct to the UAE controllers.

Simulator based testing of smoke filled environments highlighted the difficulties inherent in a smoke filled environment.

There are several attempts by the UAE ATC to contact the flight on the guard frequency in conjunction with aircraft relaying information or flights questioning who is transmitting on the guard frequency.

The communication problems could have alleviated had the checklist directed the crew to tune at least one radio to the destination aerodrome or area control frequencies in the transit FIR.

## 2.24 Checklist – Smoke, Fire and Fumes – Format Improvements

---

There have been several industry initiatives to alter the perception of risk for smoke, fire and fumes events in commercial transport category aircraft<sup>94</sup>

Large transport category aircraft specifically cargo operators, where there is a large Class E cargo compartment with a large volume and mass of combustible material should have specific smoke, fire and fumes mitigation implemented to support the crews in the event that there is a large cargo fire.

---

<sup>94</sup> Smoke, Fire and Fumes in Transport Aircraft, Past History, Current Risk and Recommended Mitigations  
A Specialist Paper prepared by Captain John M. Cox, FRAeS President, Safety Operating Systems (USA)

The crew of the accident flight were in a complete smoke filled environment within three minutes of the alarm.

All cockpit vital actions, including flight management and safe navigation through the airways is predicated on the smoke clearance procedures clearing smoke or fumes and that the crew will be able to view the panels, instruments and outside of the cockpit.

If this presumption is not met, all ability to perform the required vital actions are rendered redundant, unless there is an alternative method to view the required panels.

The recommendations in the various working papers and industry review reports are centered around this risk mitigation.

One problem, and it was highlighted by this accident is the QRH checklist. The investigation team set up and ran two different smoke, fire, fumes simulator sessions.

One was in a Boeing 744 simulator to perform several verification and observation sessions of the crew vital actions and measure and record the CRM and decision making processes in reduced visibility

The second was in an A330, an envelope protected aircraft with a high degree of automation, and relatively hands free.

In each case, the regardless of the aircraft's technical sophistication, the crew are required to read from a QRH.

It is counterintuitive if the primary problem is the requirement to view objects, that the requirement to achieve critical tasks is based on the crews ability to read, comprehend and perform the required vital actions if these are not memory items.

The numerous checklist enhancements regarding font, size and background colour should be implemented at a regulatory level; particularly where large transport aircraft are concerned.

The simulator sessions results and conclusions are in the Appendices.

## 2.25 Audible Checklists – Smoke, Fire and Fumes

---

A smoke filled cockpit with a smoke/fumes saturation which is non-dissipating limits the ability of the crew to view the primary flight instruments and the hard copy versions of the QRH.

Several air accident reports cite examples of crews unable to function in a smoke/fumes environment where flight performance and management of vital actions cannot be accomplished as the QRH checklists cannot be read.

From an operability, cockpit ergonomics and human factors perspective it is counter intuitive to require a crew in an emergency situation to acquire functioning information by reading a checklist if the primary obstacle to completing the task is the inability to view the checklist due to smoke in the cockpit.

The implementation of audible checklists, crew activated and monitored would resolve the smoke filled cockpit viewing problem.

Cargo fires can produce dense, toxic, black smoke with heavy particulates and produce liquid residues which can render vision through goggles difficult, even if the object is in close proximity.

Aircraft manufacturers and their respective regulatory oversight organizations should investigate the possibility of audible checklists to assist in smoke, fire and/or fumes events.

The audible checklists solve several problems in a smoke filled cockpit:



- Initiation
  - Triggering can be through the mic or intercom switches
  - Could be managed through an electronic checklist or EFB adaption
  - Can be used during smoke/fume events where there is a continuous source of smoke or fumes near and contiguous with the cockpit area obstructing normal viewing
- Audible checklists could be a QRH hands free application, allowing the pilot to check and confirm vital actions
- All crew can be aware of the checklist progress, enhance the team concept for configuring the plane by keeping all crew members in the CRM loop.
- The ergonomics of handling a QRH/NNC checklist and functioning is simplified.
- Verification
  - Challenge-Response is completed through the aircraft system
- Completion
  - All crew can be aware of the checklist progress
- Interruptions and Distractions
  - High task load functions will not contribute to checklist interruption
  - Checklist flexibility to manage priority tasking or a high demand workload factors

Several working studies have assessed the scope of the task and there have been industry funded studies to collect and analyze data, for example a recent peer reviewed paper comparing the effects of simulated, intelligent audible, checklists and analog checklists in simulated flight<sup>95</sup>

An ICAO working group or an equivalent organization could be established to assess the requirements, develop a research process and present the information at an industry forum for further discussion and support.

---

<sup>95</sup> 12-1-2012/Comparing the Effects of Simulated, Intelligent Audible, Checklists and Analog Checklists in Simulated Flight. Hilton, Western Michigan University,

## 2.26 Accident Comparison Between GCA Case#13-2010 and ARAIB Case# AAR1105

Accident Comparison between the GCAA Case #13/2010 and ARAIB Case# AAR1105 both involve Boeing B747-400F. The accidents occurred within a one year period, in similar circumstances

As reported in the Aircraft and Railway Accident Investigation Board [ARAIB] preliminary accident report <sup>96</sup> concerning a B747-400F aircraft which crashed into the sea on July 28, 2011.

Asiana Airlines flight 991, B747-400F, reported a cargo fire to Shanghai Area Control Center and declared an emergency 50 minutes after takeoff from Incheon International Airport . The flight crashed into international waters 130 km west of Jeju International Airport, 1 hour 8 minutes after takeoff or about 18 minutes after the declaration of the emergency when it attempted to divert to Jeju Airport.

Given the similarity to the GCAA investigation including the aircraft type, cargo, emergency declaration, handling issues identified, the time frame and the flight profile the GCAA, ARAIB and the NTSB met in Washington for the respective agencies to brief on common points of interest regarding the accidents..

Order	Time	Transmitter	Summary of ATC/Pilot Communications
1	03:51:15	AAR991	Made initial contact with SHI ACC (FO)
2	03:54:23	AAR991	Requested SHI ACC to allow emergency descent and declared an emergency due to a fire (FO)
3	03:55:08	AAR991	Requested a diversion to Jeju (FO)
4	03:56:02 - 03:58:03	SHI ACC	Had communication with AAR991 pilots about diversion, descent altitude and the airport for diversion
5	03:59:26	AAR991	Reported to SHI ACC descent to 10,000 ft due to a rear cargo fire <sup>4)</sup> and requested a radar vector to Jeju Airport(FO)
6	04:05:32	KAL886	Relayed ICN ACC's instructions to the AAR991 captain, and the captain replied * Heading 060, descent to 7,000 ft
7	04:05:49 - 04:06:30	AAR991	Had communication with the KAL886 pilot to confirm heading and descending altitude
8	04:06:32	AAR991	The captain said to KAL886, "We are now that rudder control is not working."
9	04:07:34	AAR991	The captain stated, "We have to open the hatch."
10	04:09:47	AAR991	The captain replied to KAL886's question about the control, "Rudder control... flight control, all are not working."
11	04:10:06	AAR991	The FO stated, "We have heavy vibration on the airplane, may need to make an emergency landing, emergency ditching."
12	04:10:15	AAR991	The FO stated, "Altitude control is not available due to heavy vibration, going to ditch... ah." * Afterwards, there was no communication between ATC and AAR991.

[Table 2] Major ATC/Pilot Communications

The timing and sequence of the events prior to the loss of communication were compared.

The pallet locations are different, with the UPS accident the freight, and the fire origin was in pallet positions 4-5, loaded forward. For the Asiana accident the hazardous material freight is loaded to the aft, adjacent to the main cargo loading door. Where the Asiana cargo ignited is not known.

96

<http://araib.mltm.go.kr/LCMS/DWN.jsp?fold=airboard0201&fileName=Interim+Report%28Asiana+Airlines+Cargo+Flight+991+Accident%29.pdf>

Three factors are of relevance concerning the aircrafts behaviour: 1.evidential fire damage, 2,the event time frame and 3. the control issues prior to the loss of control inflight.

One, the smoke vent discharge sooting from the cockpit overhead smoke shutter are similar

Two, the general time frame was consistent with a large uncontained cargo fire

Three, the Captain replied to a question about the control, "Rudder control... flight control, all are not working."

The radar tracking data indicates the aircraft was climbing and descending in phugoid oscillation<sup>97</sup>. It is a dynamic mode. This can result from various controllability problems, a trimable horizontal stabiliser in fixed pitch, an unresponsive pitch control system and a constant thrust setting is one set of parameters that can induce this.

The two fire alerts to the crew [UPS and Asiana] occurred in similar flight phases, either climbing or recently established at the cruise altitude.

Based on the NTSB cargo pallet and container fire testing, approximately within ten minutes a large catastrophic fire can occur which cannot be contained

---

<sup>97</sup> variation of air-speed, pitch angle, and altitude, with minimal variation in angle-of-attack variation

## 3. FINDINGS, CAUSES AND CONTRIBUTING FACTORS

### General information on the Findings, Causes and Contributing Factors Section

From the evidence available, the following causes, contributing factors, safety issues and other key findings were made with respect to this accident.

To serve the objective of this Investigation, the following sections are included in the Conclusions.

- **Findings** The findings are statements of all significant conditions, events or circumstances in the accident sequence. The findings are significant steps in the accident sequence, but they are not always causal or indicate deficiencies.
- **Causes** are actions, omissions, events, conditions, or a combination thereof, which led to this accident.
- **Contributing Factors** are actions, omissions, events, conditions, or a combination thereof, which, directly contributed to the Accident and if eliminated or avoided, would have reduced the probability of this Accident occurring, or mitigated the severity of its consequences.

### 3.1 FINDINGS

---

***Findings** The findings are statements of all significant conditions, events or circumstances in the accident sequence. The findings are significant steps in the accident sequence, but they are not always causal or indicate deficiencies.*

1. The crew of the inbound sector from Hong Kong reported a PACK 1 failure. This failure could not be replicated on the ground in Dubai by the ground engineer.
2. The Boeing 747-400 fleet was experiencing a lower than predicted MTBF of the turbine bypass valve [TBV], which is a component of the AC PACKs.
3. A consignment of mixed cargo including a significant number of batteries, including lithium types, was loaded on the inbound flight from Hong Kong onto the pallets located at MD positions 4, 5, and 6, amongst other positions. This cargo was not unloaded in Dubai.
4. At least three shipments including lithium type batteries should have been classified and fully regulated as Class 9 materials per ICAO Technical Instructions, and thus should have appeared on the cargo manifest. These shipments were located in the cargo at MD positions 4 and 5.
5. Shippers of some of the lithium battery cargo loaded in Hong Kong did not properly declare these shipments and did not provide Test Reports in compliance with the UN Recommendations on the Transport of Dangerous Goods Manual of Tests and Criteria, Section 38.3, to verify that such these battery designs were in conformance with UN Modal Regulations.
6. The aircraft was airworthy when dispatched for the flight, with MEL items logged. These MEL items are not contributory to the accident.
7. The mass and the Center of Gravity [CG] of the aircraft was within operational limits.
8. The crew was licensed appropriately and no fatigue issues had been identified.
9. The Captains blood sample was positive for ethyl alcohol with a concentration of (11 mg/dl).
10. Currently a universal fire protection certification standard covers all transport category aircraft.
11. FAA Advisory Circular 25-9A *Smoke Detection, Penetration, And Evacuation Tests And Related Flight Manual Emergency Procedures* does not require the consideration of continuous smoke generation

- for cockpit smoke evacuation, the FAA recommends that the airframe design address this situation but it is not mandatory.
12. The crew were heard to confirm the oxygen mask settings during preflight, however sound spectrum analysis indicated that for unknown reasons, the First Officer's mask was set to Normal instead of 100%, which likely allowed ambient air contaminated with smoke to enter his mask.
  13. The take-off at 14:50 UTC and initial climb were uneventful.
  14. At 14:58 UTC, Pack 1 went off line and was reset 2 minutes later by the PM.
  15. The crew acknowledged Bahrain radar and crossed into the Bahrain FIR at 15:11 UTC.
  16. At some point prior to the fire warning, contents of a cargo pallet, which included lithium batteries, auto-ignited, causing a large and sustained cargo fire which was not detected by the smoke detectors when in the early stages of Pyrolysis.
  17. Pallets with rain covers can contain smoke until a large fire has developed.
  18. Two minutes after passing into the Bahrain FIR, Twenty one minutes after take-off there is a fire alert at 15:12 indicating a, FIRE MAIN DK FWD.
  19. The Captain assumes control as Pilot Flying, the F.O begins the FIRE MAIN DK FWD non-normal checklist.
  20. The Capt advises the F.O they are to return to DXB before alerting Bahrain Area East Control [BAE-C] of the fire onboard, declaring an emergency and requesting to land as soon as possible.
  21. BAE-C advised the crew that Doha airport was 100 nm to the left. The turn back to DXB totaled 185 nm track distance. The likely outcome of a hypothetical diversion is inconclusive.
  22. At the time the Captain decided to turn back, the crew was not yet aware of the full extent of the fire and its effects.
  23. By the time that the smoke in the cockpit and fire damaged controls became apparent, diverting to Doha was no longer a feasible option.
  24. The course to DXB resulted in the airplane flying out of direct radio communication with ATC, requiring a complex relay of communication and increased task saturation for the F.O.
  25. In addition to the energy release from Lithium batteries resulting in combustion, there is an associated mechanical energy release. This mechanical energy release is capable of compromising the integrity of packaging and creating incendiary projectiles.
  26. The control of the aircraft when in manual control was compromised due to the thermal damage to the control cable assemblies. The first indication of the deteriorated synchronization problems between the control column movement and elevator position appear when the Captain disconnects the autopilot.
  27. The time interval between fire detection and the onset of aircraft system failures was two minutes and thirty seconds at the point of detection. In all probability the fire had damaged the control cables prior to autopilot disconnection.
  28. The aircraft begins to turn on to a heading for DXB and descends. As it was dusk, the aircraft is now descending to the east and back into an easterly time zone where there is limited available ambient solar light.
  29. The cargo compartment liner failed as a fire and smoke barrier under combined thermal and mechanical loads.
  30. Consequently, the damaged cargo compartment liner exposed the area above the cargo bay in fire zone 3 to sustained thermal loading either breaching the cargo compartment liner or causing the aluminium structure retaining the liner to collapse, exposing the area above and adjacent to the breach to continuous thermal loading.
  31. Consequently, the damaged cargo compartment liner exposed the supernumerary and cockpit area to sustained and persistent smoke and toxic fumes.

32. Based on the NTSB pallet and container testing results, it is now known that the growth rate of container fires after they become detectable by the aircraft's smoke detection system can be extremely fast, precluding any mitigating action and resulting in an overwhelming fire that cannot be contained.
33. The high thermal loading damaged or destroyed the supporting trusses for the control cables directly affecting the control cable tension. The control column effectiveness was significantly reduced, subsequently the movement of the elevators, speed brake, rudders, brakes and landing gear control had been compromised.
34. The high thermal loading caused damage to the ECS ducting,
35. The ACARS/AHM data indicates a series of sensor failures and fire wire loops tripping to active in the area of the fire, the fault timing and the fire warning are corollary.
36. The crew donned their oxygen masks, and experienced difficulty hearing each other.
37. The oxygen masks had a required setting of 100% and in emergency for smoke in the cockpit.
38. The oxygen selector position cannot be viewed when the mask is on. The technique used to determine the selector position when the mask was on was not an operator technique or reinforced through training scenarios and non-cognitive muscle memory techniques.
39. The mask settings remain unchanged for the duration of the flight.
40. The main deck fire suppression system was activated and the cabin depressurized.
41. Lithium-metal cell thermal stability and reactions that occur within a cell with elevated temperatures, up to the point of thermal runaway are not oxygen dependent. Electrolyte or vent gas combustion properties and the fire hazards associated with thermal runaway reactions do not respond to the FL250 assumed hazard mitigation methodology.
42. The Class E cargo compartment fire suppression strategy of preventing venting airflow in to cargo compartment, depressurization and maintaining 25,000ft cabin altitude may not be effective for Class D metal fires.
43. For unknown reasons Pack 1 went off and was not mentioned by the crew. The cockpit smoke prevention methodology when the fire suppression is active is to have pack one on low flow pressurizing the cockpit area to a higher than ambient pressure, preventing smoke ingress.
44. It is unknown in this instance that if Pack one had been active this method would have worked as described based on the volume and flow of the smoke The Capt requests a descent to 10,000ft
45. The QRH Fire Main Deck checklist does not address the key factor of descend or divert decision making. The checklist fire suppression methodology advises the crew to remain at 25,000 cabin pressure altitude to suppress a fire or land at nearest suitable airport. It does not provide guidance for when or how to transition to landing or the fact that descending early might provide more atmospheric oxygen to the fire. There is no intermediate step to verify or otherwise assess the condition of the fire and to evaluate the risk to the aircraft if a descent is initiated.
46. The Class E certification standards for fire suppression does not require active fire suppression.
47. Within three minutes of the fire alarm, smoke enters the cockpit area. This smoke in the cockpit, from a continuous source near and contiguous with the cockpit area, entered with sufficient volume and density to totally obscure the pilot's view of the instruments, control panels and alert indicating systems for the duration of the flight.
48. Once the liner had been breached, the openings in the liner would progressively expand, allowing an increase in the volume of dense noxious smoke, fire and combustion by-products to escape the cargo compartment.
49. The cargo compartment liner structure certification does not include extreme heat and other input loads such as vibration, multi-axial loading, intermittent pressure pulses, thermo mechanical loadings based on differential materials coefficients, acoustic and ballistic damage testing.

50. The crew made several comments concerning their inability to see anything in the cockpit. The crew in the smoke environment had reduced visibility and could not view the primary instruments such as the MFD, PFD, Nav Displays or the EICAS messages.
51. The Captain selected the Autopilot on and leveled out following the pitch control problems. The aircraft remained in a stable steady state when controlled via the AP. There was no communication between the Captain and the F.O. that the controllability problem was resolved using the AP.
52. Effective elevator and rudder control was only available with the autopilots. The aircraft was controllable with the AP as the servos are electrically controlled and hydraulically actuated, which for pitch control is in the tail section aft of the rear pressure bulkhead, and the fire had not compromised the electrical cabling to the actuators.
53. The PF was not fully aware of the extent of the control limitations, could not see the EICAS messages and was not aware of all of the systems failures.
54. The Captain called for the smoke evacuation handle to be pulled as the smoke accumulated in the cockpit. The smoke evacuation handle when pulled opens a port in the cockpit roof, which if the smoke is sustained and continuous, will draw smoke through the cockpit as the pressure is reduced by the open port venturi effect compounding the problem. The smoke evacuation handle remained open for the remainder of the flight.
55. There are several instances of checklist interruption at critical times at the beginning of the emergency. The speed and quick succession of the cascading failures task saturated the crew. The smoke in the cockpit, combined with the communications problems further compounded the difficult CRM environment. With the incapacitation of the captain, the situation in the cockpit became extremely difficult to manage.
56. One factor when dealing with the QRH and running checklists is that the B747 does not have a hot microphone function. This caused increasing difficulty managing cascading failures and high workload.
57. The crew was unable to complete the Fire Main Deck checklist. The aircraft was not leveled off at 25,000 ft. Directly descending to the 10,000 ft may have exacerbated fire and smoke problem due to the extra available oxygen.
58. The Captain instructed the F.O. to input DXB RWY12L into the FMC. This action was completed with difficulty due to the smoke. There was no verbal confirmation of the task completion, however, the the aircraft receivers detected the DXB Runway 12L glide slope beam when approaching Dubai.
59. Captain made a comment mentioning the high cockpit temperature, almost immediately the Captains oxygen supply abruptly stopped without warning, this occurred seven minutes six seconds after the first Main Deck Fire Warning.
60. The Captain's inability to get oxygen through his mask was possibly the result of the oxygen hose failure near the connector. The high thermal loading was conducted through the supplementary oxygen stainless steel supply lines heating the supplementary oxygen directly affecting the flexible hose connector causing the oxygen supply line to fail.
61. Systems analysis indicates that the oxygen supply is pressure fed, therefore venting oxygen could be released by a failed oxygen hose which could then discharge until the oxygen line fails or the oxygen supply is depleted.
62. The Captain requests oxygen from the F.O. several times over approximately one minute. The First Officer due to possible task saturation was not able to assist the Captain.
63. The oxygen requirement of the Captain became critical, the Captain removes the oxygen mask and separate smoke goggles and leaves the seat to look for the supplementary oxygen. The Captain did not return. The Captain was in distress locating the supplementary oxygen bottle and could not locate it before being overcome by the fumes.

64. The Captain was incapacitated for the remainder of the flight. A post-mortem examination of the Captain indicates that the cause of death was due to carbon monoxide inhalation.
65. A full face emergency oxygen supply is available in the cockpit. Oronasal masks are available in the lavatory, jump seat area and crew bunk area.
66. Due to the Captain's incapacitation the F.O became P.F. for the remainder of the flight, operating in a single pilot environment. Exposure to this type of environment in a controlled training environment could have been advantageous to the remaining crew member.
67. The FO had breathing difficulties as the aircraft descended as the normal mode function of the mask supplies oxygen at a ratio to atmospheric, ambient air. The amount of oxygen supplied was proportional to the cabin altitude.
68. The cockpit environment remained full of smoke in the cockpit, from a continuous source near and contiguous with the cockpit area for the duration of the flight.
69. As the flight returned towards DXB, the crew were out of VHF range with BAE-C and should have changed VHF frequencies to the UAE FIR frequency 132.15 for the Emirates Area Control Center [EACC]. Due to the smoke in the cockpit the PF could not view the audio control panels to change the frequency selection for the duration of the flight.
70. The flight remained on the Bahrain frequency 132.12 MHz on the left hand VHF ACP for the duration of the flight. To solve the direct line of communication problem, BAE-C requested traffic in the vicinity to relay communication between crew and BAE-C.
71. The PF made a blind Mayday call on 121.5 MHz at 15:21 UTC.
72. The PF had to relay all VHF communication through other aircraft. The radio communication relay between the PF, the relay aircraft and the ANS stations resulted in confusion communicating the nature and intent of the PF's request for information with the required level of urgency.
73. The PF requested from the relay aircraft immediate vectors to the nearest airport, radar guidance, speed, height and other positional or spatial information on numerous occasions to gauge the aircraft's position relative to the aerodrome and the ground due to the persistent and continuous smoke in the cockpit.
74. The relay aircraft did not fully comprehend or communicate to the BAE-C controller the specific nature of the emergency and assistance required, particularly towards the end of the event sequence.
75. There was a multi-stage process to complete a standard request for information between the accident flight and the destination aerodrome via the relay aircraft and the ATCU.
76. The flight crew did not or could not enter the transponder emergency code 7700, however all ATCUs were aware that the airplane was in an emergency status.
77. DXB controllers were aware that the flight was in an emergency status, however were not aware of the specific nature of the emergency or assistance required, due to the complex nature of the relayed communications.
78. There was no radar data sharing from the UAE to Bahrain ATC facilities. Bahrain had a direct feed that goes to the UAE but there was no reciprocal arrangement. This lack of data resulted in the BAE-C ATCO not having radar access the SSR track of the accident flight.
79. The ATC facilities are not equipped with tunable transceivers.
80. The accident aircraft transmitted on the Guard frequency 121.5 Mhz. The transmissions were not heard by the EACC or DXB ATC planners due to the volume of the 121.5 Mhz frequency being in a low volume condition.
81. The PF did not respond to any of the calls from the ACC or the relay aircraft on 121.5 MHz, which were audible on the CVR, after the Mayday transmission.



82. During the periods when direct radio communications between the pilot flying and the controllers was established, there was no negative effect. Therefore it is likely that if direct 121.5 contact had been established the communications task could have been simplified.
83. The relay aircraft hand off between successive aircraft caused increasing levels of frustration and confusion to the PF.
84. All Dubai aerodrome approach aids and lighting facilities were operating normally at the time of the accident.
85. There is no requirement for full immersion smoke, fire, fumes cockpit training for flight crews.
86. The PF selected the landing gear handle down. The landing gear did not extend, likely due to loss of cable tension.
87. The flaps extended to 20°. This limited the auto throttle power demand based on the max flap extension placard speed at 20° Flaps.
88. The PF was in radio contact with a relay aircraft, who advised the PF through BAE-C that Sharjah airport was available, and a left hand turn onto a heading of 095° was required.
89. The PF made an input of 195° into the MCP for an undetermined reason when 095° was provided. The aircraft overbanked to the right, generating a series of audible alerts. It is probable that the PF, in the absence of peripheral visual clues, likely became spatially disorientated by this abrupt maneuver.
90. The aircraft acquired 195°, the AP was selected off. The throttle was retarded and the aircraft began a rapid descent.
91. The PF was unaware of the large urban area directly in the airplane's path. The aircraft began a descent without a defined landing area ahead.
92. Spatial disorientation, vestibular/somatogyral illusion due to unreliable or unavailable instruments or external visual references are a possibility. The PF was unaware of the aircraft location spatially. The PF may have been attempting an off airfield landing, evidenced by numerous control column inputs.
93. The control column inputs to the elevators had a limited effect on the descent profile. The pilot made a series of rapid column inputs, in response to GPWS warnings concerning the sink rate and terrain. The inputs resulted in pitch oscillations where the elevator response decreased rapidly at the end of the flight
94. The available manual control of pitch attitude was minimal, the control column was fully aft when the data ends, there was insufficient trailing edge up [nose up] elevator to arrest the nose down pitch. Control of the aircraft was lost in flight followed by an uncontrolled descent into terrain.
95. The aircraft was not equipped with an alternative viewing system to allow the pilot(s) to view the instruments and panels in the smoke filled environment.

## 3.2 CAUSES

---

*Causes are actions, omissions, events, conditions, or a combination thereof, which led to this accident.*

- 3.2.1 A large fire developed in palletized cargo on the main deck at or near pallet positions 4 or 5, in Fire Zone 3, consisting of consignments of mixed cargo including a significant number of lithium type batteries and other combustible materials. The fire escalated rapidly into a catastrophic uncontained fire.
- 3.2.2 The large, uncontained cargo fire, that originated in the main cargo deck caused the cargo compartment liners to fail under combined thermal and mechanical loads.
- 3.2.3 Heat from the fire resulted in the system/component failure or malfunction of the truss assemblies and control cables, directly affecting the control cable tension and elevator function required for the safe operation of the aircraft when in manual control.
- 3.2.4 The uncontained cargo fire directly affected the independent critical systems necessary for crew survivability. Heat from the fire exposed the supplementary oxygen system to extreme thermal loading, sufficient to generate a failure. This resulted in the oxygen supply disruption leading to the abrupt failure of the Captain's oxygen supply and the incapacitation of the captain.
- 3.2.5 The progressive failure of the cargo compartment liner increased the area available for the smoke and fire penetration into the fuselage crown area.
- 3.2.6 The rate and volume of the continuous toxic smoke, contiguous with the cockpit and supernumerary habitable area, resulted in inadequate visibility in the cockpit, obscuring the view of the primary flight displays, audio control panels and the view outside the cockpit which prevented all normal cockpit functioning.
- 3.2.7 The shutdown of PACK 1 for unknown reasons resulted in loss of conditioned airflow to the upper deck causing the Electronic Equipment Cooling [EEC] system to reconfigure to "closed loop mode". The absence of a positive pressure differential contributed to the hazardous quantities of smoke and fumes entering the cockpit and upper deck, simultaneously obscuring the crew's view and creating a toxic environment.
- 3.2.8 The fire detection methodology of detecting smoke sampling as an indicator of a fire is inadequate as pallet smoke masking can delay the time it takes for a smoke detection system to detect a fire originating within a cargo container or a pallet with a rain cover.

### 3.3 CONTRIBUTING FACTORS

---

**Contributing factors.** *Actions, omissions, events, conditions, or a combination thereof, which, if eliminated, avoided or absent, would have reduced the probability of the accident or incident occurring, or mitigated the severity of the consequences of the accident or incident.*

*The identification of contributing factors does not imply the assignment of fault or the determination of administrative, civil or criminal liability.*

- 3.3.1 There is no regulatory FAA requirement in class E cargo compartments for active fire suppression.
- 3.3.2 Freighter main deck class E fire suppression procedures which rely on venting airflow and depressurisation as the primary means of controlling a fire are not effective for large Class E cargo fires involving dangerous goods capable of Class D metal fire combustion.
- 3.3.3 No risk assessment had been made for the failure of the cargo compartment liner based on the evolution of cargo logistics and associated cargo content fire threats, cargo hazards and bulk carriage of dangerous goods.
- 3.3.4 The regulation standards for passive fire suppression do not adequately address the combined total thermal energy released by current cargo in a large cargo fire and the effect this has on the protection of critical systems.
- 3.3.5 FAA and EASA regulatory requirements do not recognize the current total fire risk associated with pallets, pallet covers and containers as demonstrated by the NTSB/FAA testing.
- 3.3.6 Class 9 Hazmat packing regulations do not address the total or potential fire risk that can result from lithium battery heat release during thermal runaway. Although non-bulk specification packaging is designed to contain leaks and protect the package from failure, the packaging for Class 9 does not function to contain thermal release.
- 3.3.7 The growth rate of container and pallet fires after they become detectable by the aircraft's smoke detection system can be extremely fast, precluding any mitigating action and resulting in an overwhelming total energy release and peak energy release rate for a standard fire load that cannot be contained.
- 3.3.8 The course to return to Dubai required a series of complex radio communication relays due to the Pilot Flying's inability to view and tune the radio transceivers.
- 3.3.9 The relay communication between the Pilot Flying, relay aircraft and the various ATC stations resulted in communication confusion, incomplete and delayed communications, which contributed to the escalated workload and task saturation for the Pilot Flying.
- 3.3.10 The Fire Main Deck non-normal checklist in the QRH was not fully completed by the crew or adhered to regarding the fire suppression flight level or land at nearest airport instruction.
- 3.3.11 Task saturation due to smoke and multiple systems failures prevented effective use of the checklist by the crew.
- 3.3.12 Communications between the ATCO units involved multiple stages of information exchange by landline and the destination aerodrome was not fully aware of the specific nature of the emergency, the difficulty that the Pilot Flying was experiencing or the assistance required.
- 3.3.13 The Pilot Flying had not selected transponder code 7700, the emergency code, when radio communication with the destination aerodrome was not established.

- 3.3.14 Task saturation due to smoke and multiple systems failures prevented effective use of the checklist by the crew
- 3.3.15 The incapacitation of the Captain early in the event sequence, resulted in a single pilot scenario. The numerous cascading failures and smoke in the cockpit resulted in task saturation and an extreme workload for the remaining pilot.
- 3.3.16 The crew was not equipped with an alternative vision system or method for managing a smoke filled cockpit that would allow the crew to view the primary instruments.

## 4. SAFETY RECOMMENDATIONS

**Advisory Note:** In the Section 2, Analysis, reference is made to the FAA CFR14 regulations, so, for those Safety Recommendations addressed both to FAA and EASA, they are written as follows: **“FAA in co-operation (or in coordination) with EASA to”**. In this case FAA will act as the focal point and as the responsible authority for replying to the Safety Recommendations, which will be coordinated with EASA.

### 4.1 SR 25/2013:

The FAA in co-operation or in coordination with EASA to review the single, universal, CFR14 fire protection certification standard that covers all transport category aircraft as a single design category and develop a dedicated protection certification standard for the cargo compartments of aircraft designed or modified as dedicated freighter or freighter/passenger combi aircraft to include the mandatory installation of fire suppression systems of cargo aircraft with Class E cargo compartments.

### 4.2 SR 26/2013:

The FAA and EASA are requested to provide operators of cargo aircraft of a maximum certificated take-off mass in excess of 45,500 kg with the option to modify existing Class E cargo compartments, through a process of FAA or EASA recommended modifications, to control a class E cargo fire without requiring a crewmember to enter the compartment through the use of an active fire suppression system.

### 4.3 SR 27/2013:

The FAA in co-operation or in coordination with EASA to mandate the requirement for cargo aircraft certified under FAA 14CFR or the equivalent EASA certification requirements to have a method of detecting the early development of fire through the detection of thermal radiation, originating within class E cargo compartments, through the installation of Multi-Source Sensors [MSS] which utilise a process of thermal/heat detection in conjunction with smoke/fumes sampling.

### 4.4 SR 28/2013:

The FAA in co-operation or in coordination with EASA to review the certification requirement for crew alerting to provide a visual means of indicating the specific location of a fire to the crew.

### 4.5 SR 29/2013:

GCAA recommends that PHMSA standardise the battery packaging regulation to be in harmony with the ICAO Technical Instructions [TI].

The requirement is the complete harmonization of the U.S. HMR with the ICAO TI's for the Safe Transport of Dangerous Good by Air regarding lithium batteries. This includes incorporation of quality management provisions provided in Part 2; 9.3.1 e.

### 4.6 SR 30/2013:

The FAA in co-operation or in coordination with EASA to develop standards for containers with suppression systems, superior heat and fire resistance and resiliency to withstand a suppression-

caused pressure pulse and still contain a suppression agent in accordance with NTSB recommendations contained in NTSB A-12-68,69,70<sup>98</sup>.

#### 4.7 SR 31/2013

The FAA in co-operation or in coordination with EASA to implement certification rule changes to require containers or Unit Load Devices (ULDs) which meet the standards in recommendation 4.6, develop a design standard that enables the container or ULD to be capable of internally containing or suppressing a fire agent in accordance with NTSB recommendations contained in NTSB A-12-68,69,70.

#### 4.8 SR 32/2013:

The FAA to develop an Advisory Circular [AC] addressing the use of fire containment covers for cargo stored on pallets that could be used to cover palletized cargo or cargo containers.

#### 4.9 SR 33/2013:

The FAA in co-operation or in coordination with EASA to provide a requirement for mandatory full-face oxygen.

#### 4.10 SR 34/2013:

The FAA in co-operation or in coordination with EASA to recommend the adoption of a rotary single piece selector for oxygen quick donning anti-smoke oxygen masks.

#### 4.11 SR 35/2013:

The FAA in co-operation or in coordination with EASA to require the use of Evidence Based Training Programs [EBTP] in line with the requirement of ICAO Document 9995 - Manual of Evidence Based Training. In particular, require operators to implement the development of evidence based simulator training using objective FOQA accident and serious incident data of smoke filled cockpit environments for crew emergency training.

#### 4.12 SR 36/2013:

The FAA in co-operation or in coordination with EASA to mandate the implementation of vision assurance devices or technology for improved pilot visibility during continuous smoke, fire, fumes in the cockpit emergencies. This could include off the shelf devices or developing mask mounted thermal imaging cameras with the capability to see through smoke/fumes with sufficient clarity to view the primary cockpit instrumentation.

#### 4.13 SR 37/2013:

The FAA in co-operation or in coordination with EASA to develop or redesign all transport aircraft checklists pertaining to Smoke Fire Fumes events to be consistent with the Integrated, Non-alerted Smoke Fire Fumes Checklist template presented in the Royal Aeronautical Society's

---

<sup>98</sup> NTSB A-12-68,69,70

Develop fire detection system performance requirements for the early detection of fires originating within cargo containers and pallets and, once developed, implement the new requirements. (A-12-68)

Develop fire detection system performance requirements for the early detection of fires originating within cargo containers and pallets and, once developed, implement the new requirements. (A-12-69)

Develop fire detection system performance requirements for the early detection of fires originating within cargo containers and pallets and, once developed, implement the new requirements. (A-12-70)

specialist document Smoke, Fire and Fumes in Transport Aircraft: Past History, Current Risk and Recommended Mitigations, second edition 2013, prepared by the Flight Operations Group of the Royal Aeronautical Society.

4.14 SR 38/2013:

The FAA in co-operation or in coordination with EASA to review the capability of Portable Electronic Device (PED) Electronic Flight Bags (EFB) which are used for non-alerted smoke fire fumes events to be viewed in smoke filled cockpits.

4.15 SR 39/2013:

The FAA in co-operation or in coordination with EASA to provide cargo crews with a revised Fire Main Deck non-normal checklist guidance for when and how to transition from the current 22-25,000 feet fire suppression altitude to the landing phase where descending early may contribute atmospheric oxygen to a latent fire during descent. This procedure should provide a method to verify or otherwise assess the condition of the fire and to evaluate the risk to the aircraft if a descent is initiated so as not to jeopardise the safety of the crew by following the checklist instruction as directed.

4.16 SR 40/2013:

The FAA in co-operation or in coordination with EASA to mandate a certification requirement for continuous smoke testing for flight deck smoke evaluation tests where the smoke is required to be continuously generated throughout the test for cockpit smoke clearance and develop a mitigation procedure through regulation on how to effectively manage continuous smoke in the cockpit.

4.17 SR 41/2013:

The FAA in co-operation or in coordination with EASA and Boeing to evaluate the Boeing 747 Freighter/Combi/BCF modified aircraft for single points of failure where the critical systems protection of the aircraft is dependent on a single safety gate which is the cargo compartment liner at or contiguous with fire zone three: this is the area under the control cable truss assembly, the ECS ducting and the supplementary oxygen system supply line from the forward lower deck cargo hold to the crew oxygen storage boxes.

If a deficiency in the current level of critical systems protection is determined, provide regulatory oversight to mitigate the risk of control and systems damage that can result from large cargo fires.

4.18 SR 42/2013:

The FAA in co-operation or in coordination with EASA to review the certification and design of Boeing 747 Freighter/Combi/BCF aircraft distribution of oxygen from the supplementary oxygen bottles to the flight deck oxygen masks primarily provided through corrosion resistant steel (CRES) 21-6-9 tubes. In particular, to review the critical systems protection requirements for the area connecting the CRES supply line, via a PVC hose and connector, to the oxygen mask stowage box [MXP147-3] and provide regulatory oversight to mitigate the risk of control and systems damage that can result from large, catastrophic cargo fires.

4.19 SR 43/2013:

The FAA in co-operation or in coordination with EASA are requested to charter an Advisory and Rulemaking Committee (ARAC) to review the adequacy of current issue papers on the protection of critical systems from cargo fires and develop regulations and associated guidance material (e.g. Advisory Circulars) to codify the existing and proposed requirements.

4.20 SR 44/2013:

The FAA in co-operation or in coordination with EASA to require operators to implement smoke, fire, fumes training in a dedicated smoke simulator/full immersion training device allowing crews to experience actual levels of continuous smoke in a synthetic training device or other equivalent ground-based training device as an integral process in crew emergency recurrent training.

4.21 SR 45/2013:

The FAA in co-operation or in coordination with EASA to implement specific Standard Operating Procedures [SOP] for scenario based multi-crew pilot incapacitation where one or more crew members are incapacitated resulting in a single pilot crew environment.

4.22 SR 46/2013:

The FAA in co-operation or in coordination with EASA to implement a specific recommendation that failures of aircraft systems (such as the air conditioning packs) necessary for the continued safe flight and landing during an aircraft cargo fire event be considered in the aircraft level safety analysis and during the development of cargo fire emergency procedures. This should consider failures of dependant systems and the continued cascading failure of systems which are factors in large cargo fires.

4.23 SR 47/2013:

FAA and EASA regulatory certification standards to consider the development of a quantitative framework for assessing the degradation of cargo compartment liner polymer matrix or the current industry standard panel material properties and the resulting degradation in the structural integrity of these structures when subjected to extreme heat, vibration and/or thermo-mechanical energy.

4.24 SR 48/2013:

The FAA in co-operation or in coordination with EASA to develop a test method to determine flame penetration resistance of cargo compartment liners to extreme heat at the current certification requirement temperature combined with additional input loads such as vibration, multi-axial loading, intermittent pressure pulses, thermo-mechanical loadings based on differential materials coefficients, acoustic vibration and ballistic damage.

4.25 SR 49/2013:

The FAA in co-operation or in coordination with EASA and Boeing to evaluate the Boeing 747 Freighter/Combi aircraft Class E cargo compartment for a structural-acoustic coupling phenomena in the aircraft fuselage.

Structural-acoustic coupling phenomenon in an aircraft fuselage is a known characteristic. In large Class E cargo compartments, the structural and acoustic modes can be derived for vibration analysis. Structural and acoustic analysis could determine possible occurrences of vibration in the fuselage structure during predetermined phases of flight where the vibro-acoustic signatures can be used to determine the principle sources and transmitting paths of the vibration.

Further investigation can be performed by the manufacturers of large cargo aircraft and/or the operators of these aircraft to investigate the vibration and acoustic signatures of the cargo areas for harmonic acoustic vibration resulting from the combination of engine and fuselage vibration.



Currently there is no data for the class E cargo compartments of the B744F, If such data was available through a process of acoustic mapping for structural-acoustic coupling, this data could be used to expand the UN Manual of Tests and Criteria Para. 38.3.4.3 Test T.3: Vibration test and verification data.

This could through a process of acoustic mapping the cargo compartment interior and measuring the vibro-acoustic interior vibration and vibration and resonance of the airframe structure.

Refer to GCAA SR 4.33

4.26 SR 50/2013:

The NTSB, FAA and/or EASA fire test divisions to perform a test on lithium batteries to determine the ignition properties for lithium type batteries when subjected to external sources of mechanical energy, including acoustic energy in flight range modes, acoustic harmonic modes and a separate test to determine the susceptibility of lithium batteries to vibration from a mechanical source.

The purpose of this testing is to determine the safe limits for the air carriage of lithium type batteries in dynamic aeroelastic, vibrating structures where the battery electrolyte composed of an organic solvent [and dissolved lithium salt] could become unstable when exposed to these forms of mechanical energy.

4.27 SR 51/2013:

ICAO to review the hazardous materials classification for Class 9 materials packaging where the reconsideration of lithium batteries and other energy storage devices that are currently classified as a Class 9 hazardous material be subjected to a higher level of hazardous material classification as at present time, it is not clear that the current Class 9 hazard communication or quantity limits adequately reflect the inherent risks to aviation safety.

4.28 SR 52/2013:

ICAO to develop a SARP for package level protection of batteries being shipped to include protection from thermal degradation and damage to individual cells or cell combinations in thermal runaway, and to retard the propagation of lithium battery initiated fires to other packages in the same cargo stowage location as well as to increase the amount of time it would require for the contents of the package containing lithium batteries to provide an additional source of fuel for on-board fires initiated by other sources.

4.29 SR 53/2013:

ICAO is requested to establish a task force or working group of manufacturers, operators, and regulators to develop a concept and safety case for audible emergency checklists for non-normal emergency situations and provide a feasibility working paper for industry consideration.

4.30 SR 54/2013:

ICAO is requested to establish a task force or working group of manufacturers, operators, and regulators to develop a concept and safety case for alternative vision assistance systems for the smoke, fire and fumes events non-normal emergency situations and provide a feasibility working paper for industry consideration on the implementation requirements and required standards.

4.31 SR 55/2013:

ICAO Flight Recorder Panel to expedite the ICAO SARP on Airborne Image Recording Systems [AIRS] amendment to Annex 13 to progress of this subject due to the potential benefit to air accident investigation.

4.32 SR 56/2013:

ICAO Safety Information Protection Task Force to expedite the ICAO SARP's required for video data protection.

4.33 SR 57/2013:

ICAO Dangerous Goods Panel to amend the ICAO Technical Instructions regarding the safe carriage of lithium batteries.

Specifically, the request is to establish a dedicated task force within the DG panel, including the representation of qualified stakeholders, to study the safe carriage of lithium batteries and other potentially hazardous cargo and develop recommendations to the UN Manual of Tests and Criteria, The Manual of Tests and Criteria Revision 5, Lithium Metal and Lithium Ion Batteries, 38.3.4.3, Test T3-Vibration.

Structural-acoustic coupling phenomenon in an aircraft fuselage is a known characteristic. In large Class E cargo compartments, the structural and acoustic modes can be derived for vibration analysis. Structural and acoustic analysis can determine possible occurrences of vibration in the fuselage structure during predetermined phases of flight where the vibro-acoustic signatures can be used to determine the principle sources and transmitting paths of the vibration.

Given the active failure modes of lithium batteries, the battery risk factors concerning possible susceptibility to various extraneous forms of mechanical energy, for example vibration, possibly in a harmonic form, could be an initiating action risk.

ICAO Dangerous Goods Panel is requested to evaluate data relative to the UN Manual of Tests and Criteria, Lithium Metal and Lithium Ion Batteries, 38.3.4.3, Test T3-Vibration and advise the UNECE Committee of Experts/Working Party on the Transport of Dangerous Goods if additional criteria should be adopted for the carriage lithium metal and lithium ion batteries by air transport.

Refer to GCAA SR 4.25

4.34 SR 58/2013:

GCAA to produce an In-Flight Emergency Response Manual [IFERM] for the use of ATCO and all ANS providers. The General Civil Aviation Authority (GCAA) to issue a manual providing formal guidance for ATCO's to enhance responses to in flight emergencies. The manual should support CAR Part VIII, subparts 4 (ATS) and 8 (SAR).

4.35 SR 59/2013:

GCAA to require all ATC units be equipped with a dedicated transceiver which can be directly tuned to all frequencies in the aviation band(s) for use in emergency situations.

4.36 SR 60/2013:

GCAA to assist and/or support the provision for mutual radar data sharing between Bahrain and the UAE Flight Information Regions.

## 5. APPENDICES

### A: CARGO FACTUAL REPORT



## National Transportation Safety Board

Washington, D.C. 20594

Report Date: December 21, 2010

Cargo Group Chairman's Factual Report

#### A. Accident Identification

Accident No.: DCA10RA092  
Transportation Mode: Aviation  
Location: Dubai, United Arab Emirates (UAE)  
Date: September 3, 2010  
Time: 1151 Eastern Standard Time (EST)  
Operator: United Parcel Service Co. (UPS)  
Aircraft: Boeing 747-400F (N571UP)  
Fatalities: 2

#### B. Group Members

Crystal G. Thomas  
Group Chairman  
National Transportation Safety Board  
490 L'Enfant Plaza East, S.W.  
Washington, D.C. 20594-2000  
[crystal.thomas@ntsb.gov](mailto:crystal.thomas@ntsb.gov)  
202.314.6199 (w)  
202.255.9965 (c)

Jim Lutes  
Ground Service Stations & Facilities Manager  
United Parcel Service Co.  
825 Lotus Avenue  
Louisville, KY 40213  
[jlutes@ups.com](mailto:jlutes@ups.com)  
502.359.5075 (w)  
502.298.0186 (c)

Richard Hudes  
Hazardous Materials Specialist  
Federal Aviation Administration (FAA)  
490 L'Enfant Plaza, SW, Suite 2200  
Washington, D.C. 20594  
[richard.hudes@faa.gov](mailto:richard.hudes@faa.gov)  
202.385.4902 (w)  
202.525.0301 (c)

Kelly L. Shaffer  
Hazardous Materials Specialist  
Federal Aviation Administration (FAA)  
4154 Weeks Drive  
Warrenton, VA 20187  
[kelly.shaffer@faa.gov](mailto:kelly.shaffer@faa.gov)  
540.428.3156 (w)  
571.643.3704 (c)

Michael J. Khayata  
Senior Hazardous Materials Investigator  
Pipeline & Hazardous Materials Safety Administration (PHMSA)  
3401 Centrelake Drive, Suite 550B  
Ontario, CA 91786  
[Michael.Khayata@dot.gov](mailto:Michael.Khayata@dot.gov)  
909.937.3279 (w)  
909.390.5142 (c)

**C. The Accident**

At about 7:51 pm local time (1551 UTC), United Parcel Service (UPS) Flight 6, a Boeing 747-400F (N571UP), crashed while attempting to land at Dubai International Airport (DXB), Dubai, United Arab Emirates (UAE). The flight had departed from Dubai approximately 45-minutes earlier as a scheduled cargo flight to Cologne, Germany, but the flight crew declared an emergency and requested an immediate return to DXB. The airplane impacted inside an Emirati army base near a busy highway intersection, approximately nine miles from Dubai's international airport. The two flight crew members were fatally injured.

**D. Hazardous Materials Information**

There were no declared shipments of hazardous materials onboard the accident flight. The Cargo Group examined shipping invoices for the cargo onboard UPS 6, and at least two shipments of lithium batteries which should have been declared as hazardous materials, were identified. Please refer to Section F of this report for further information on these items.

**E. Loading of Cargo in DXB**

Prior to the flight to Dubai, cargo was loaded into all positions in Hong Kong. Upon arriving in Dubai, the Unit Load Devices (ULD) in positions 13L, 14L, 14R, 18L, 19L, and 20 were removed from the aircraft. Some of these ULD's were replaced with other out-bound ULD's. The following section describes the sequence of events associated with the offloading and reloading of UPS Flight 6.

### ***Cargo Handling Sequence***

The following cargo was removed from inbound UPS flight 6, as final destination cargo at Dubai, UAE: 14LS, 18L, 19L, and 45 pieces of loose cargo located in Aft Bulk (AB). Additionally, approximately 2,770 lbs of cargo was transferred from the ULD in position 13L to the AB loose load position to establish the new AB cargo weight of 4,020 lbs. At this point, a bulge in the collapsible ULD in position 18R was identified by Dnata<sup>99</sup> loaders working the aircraft. The bulge indicated that a load shift of packages occurred inside the ULD. According to UPS personnel at DXB, one package fell out of the ULD, from a height of approximately 5 feet. In order to remove the ULD in position 18R, the ULD in position 14R was removed and placed on the ramp. The ULD from position 18R was removed and transferred to the UPS operations hub at DXB to be reconstructed. Following the reconstruction of the ULD from position 18R, UPS indicated that a ULD serviceability check was performed. New ULD's were loaded into positions 13L (3,969lbs), 14L (4,697lbs), 18L (6,240lbs), and 19L (2,963lbs). Along with these ULD's, the reconstructed ULD from position 18R and the ULD from position 14R were reloaded onto the aircraft into their respective positions. Figure 1 shows the cargo configuration of the UPS Flight 6 aircraft main deck.

The Cargo Group posed questions with regards to the possible relocation of packages from the ULD's in positions 14R or 18R, or ULD's in any other positions of the aircraft, the reconstruction of the load from the ULD in position 18R, and training records. GCAA responded that the work was performed by the *Transguard Group (Transguard)*, using DNATA equipment; DNATA personnel did not perform the work. GCAA indicated that they interviewed the *Transguard* personnel who built up the cargo one or two days prior to the flight, but were unable to locate the personnel specifically responsible for performing the rearrangement of the collapsible container in question. GCAA indicated the *Transguard* would identify the personnel on duty during the time the rebuild occurred and report to GCAA. Further information on any relocation of the packages and training records of loading personnel were obtained directly by GCAA. GCAA indicated that no relocation or unscheduled movement of packages occurred. Additionally, GCAA indicated that training records were requested; however these records have not been received.

---

<sup>99</sup> Dnata is the largest supplier of ground handling, cargo and travel services in the Middle East and an accredited member of the International Air Transport Association (IATA).

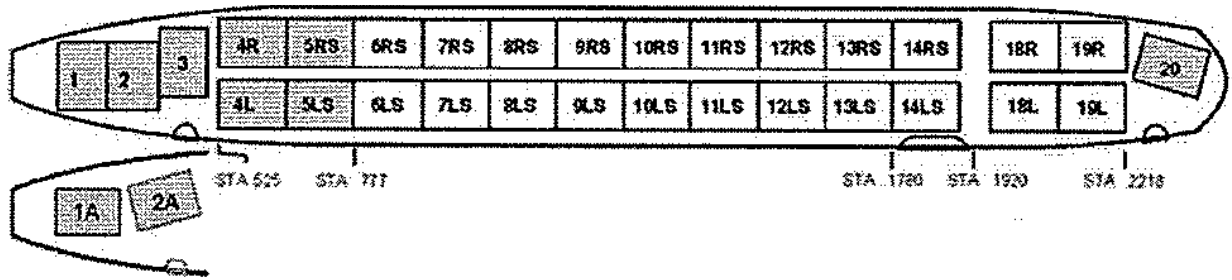

Figure 1 - Cargo Configuration of UPS Flight 6 aircraft main deck

#### F. Cargo Shipment Identification

The Cargo Group obtained package details for shipments contained in all positions onboard UPS Flight 6. The Cargo Group reviewed the package details and collaboratively identified any shipments that had generic shipment descriptions or appeared to potentially contain items that could be hazardous. The group identified many shipments of lithium batteries and electronic equipment that contained or was packed with lithium batteries. The Cargo Group obtained invoices for all identified items of interest. The group reviewed these invoices and determined 19 of the shipments to be of special interest. These invoices were found to contain discrepancies or lack the necessary information to ascertain what the items were or if they were shipped correctly. The 19 shipments of special interest are highlighted in pink on the following chart.

ULD Position	Shipment Information		
	No. Packages	Item Description	No. Pieces
1	1 of 10	LED flashlight & hoister (**incl. primary lithium battery)	1381
1	3 of 5	LED flashlight & displays (**incl. primary lithium battery)	190
1	6 of 6	Lithium-ion batteries ("BRR-L, BRR-F5, BDF-4, DFLY, BRR-LA")	648
2	1 of 1	Dry Batteries - silver oxide SR626SW	5000
2	1 of 1	Android tablet containg lithium battery	1
2	1 of 1	Phone	1
3	8 of 10	"E-book" - Invoice lists various electronics (batteries?) & 'torches'	?
3	9 of 13	Electric nail drill (various qty/pkg)	?
4L	2 of 2	Marine Radio - lithium metal batteries	12
4R	1 of 1	Power supply	128
4R	2 of 2	Various electronics (incl. lithium batteries)	?
4R	1 of 1	Various electronics (incl. lithium batteries)	?
5L	2 of 2	Mobile phones	100
5L	1 of 1	Phones	10

5R	7 of 7	Laptop power packs - lithium ion batteries	121
5R	27 of 27	Laptop batteries & adapters	393
5R	2 of 2	Watch phones (lithium battey powered)	31
6L	1 of 1	Mini E-Book	1
6L	5 of 5	Eyewear video recorder	210
6L	6 of 6	Power Supply	222
6L	13 of 13	Lithium Batteries - lithium polymer "lead out two wires and connector, the wire length: 160mm"	50
6L	3 of 3	Battery Pack - NiMH	110
6R	58 of 58	Lithium Batteries - lithium iron for electric vehicle	125
7L	2 of 26	Laptop Batteries (various qty/pkg)	?
7L	2 of 2	Phone	60
7R	26 of 26	Mobile phones w/ lithium-on battery "Non-working Dummy Phone"	1280
7R	40 of 40	Mobile phones w/ lithium-on battery "Non-working Dummy Phone"	2000
7R	40 of 40	Mobile phones w/ lithium-on battery "Non-working Dummy Phone"	2000
7R	10 of 10	Mobile phones w/ lithium-on battery "Non-working Dummy Phone"	500
7R	30 of 30	Mobile phones w/ lithium-on battery "Non-working Dummy Phone"	1500
7R	1 of 1	Mobile phones w/ lithium-on battery "Non-working Dummy Phone"	1
7R	9 of 9	Mobile phones w/ lithium-on battery "Non-working Dummy Phone"	250
7R	1 of 1	Mobile phones w/ lithium-on battery "Non-working Dummy Phone"	1
7R	1 of 1	Mobile phones w/ lithium-on battery "Non-working Dummy Phone"	1
7R	1 of 1	Mobile phones w/ lithium-on battery "Non-working Dummy Phone"	1
7R	6 of 6	Mobile phones w/ lithium-on battery "Non-working Dummy Phone"	300
7R	1 of 1	Mobile phones w/ lithium-on battery "Non-working Dummy Phone"	1
7R	1 of 1	Mobile phones w/ lithium-on battery "Non-working Dummy Phone"	1
7R	20 of 20	Mobile phones w/ lithium-on battery "Non-working Dummy Phone"	1000
8L	1 of 1	Lithium-ion batteries("Battery Sample")	200
8L	8 of 8	LED Flashlight & filter adapter (**incl. primary lithium battery)	930
8L	2 of 5	LED flashlight & displays (**incl. primary lithium battery)	190
8L	9 of 10	LED flashlight & hoister (**incl. primary lithium battery)	1381

8L	6 of 6	Mobile phones	88
8L	1 of 1	"Power supply for laptops"	65
8R	9 of 9	Lithium-ion batteries("Rechargeable battery packs")	110
<b>8R</b>	<b>10 of 10</b>	<b>Marine Power Supply</b>	<b>300</b>
9R	21 of 21	Computer desktops, mobile products & parts	?
10L	10 of 10	Batteries for headset	8
10L	9 of 9	Lithium-ion batteries (2S103450 & 3A2500)	820
10L	7 of 7	Lithium polymer batteries	250
10L	3 of 3	NiMH batteries	214
<b>10R</b>	<b>16 of 16</b>	<b>Lithium ion battery (Lithium Manganese Dioxide)</b>	<b>9670</b>
<b>10R</b>	<b>31 of 31</b>	<b>Lithium-ion battery (lifepo4)</b>	<b>30</b>
<b>10R</b>	<b>3 of 3</b>	<b>Battery (Electric zinc for bike)</b>	<b>3</b>
10R	1 of 1	E-Books	10
10R	1 of 1	Mobile phones	65
10R	1 of 1	Mobile phones	6
10R	1 of 1	Mobile phones	10
10R	1 OF 1	E-Books	1
10R	10 of 10	Lithium-ion batteries (PC batteries)	365
10R	1 of 1	Mobile phones and phone parts?	255
12L	1 of 1	Mobile phones w/ lithium-ion batteries	200
12R	1 of 1	Laptop packed w/ lithium-ion battery	1
12R	2 of 2	Apple iPad containing lithium batttery	2
13L	2 of 2	Laptops	2
13L	1 of 1	Mobile phone	1
<b>18L</b>	<b>1 of 1</b>	<b>Fuel Pump for aircraft</b>	<b>1</b>
<b>18R</b>	<b>2 of 10</b>	<b>"E-book" - Invoice lists various electronics (batteries?) &amp; 'torches'</b>	<b>?</b>
18R	2 of 13	Electric nail drill (various qty/pkg)	?
<b>18R</b>	<b>1 of 1</b>	<b>Laptop battery sample</b>	<b>2</b>
<b>18R</b>	<b>1 of 1</b>	<b>Laptop battery sample</b>	<b>2</b>



18R	20 of 20	Watch batteries ("Dry battery & Lithium metal battery")	54,800
19R	5 ctns	Mobile Internet Devices w/ lithium ion battery contained in equipment	?
P1	22 of 22	Mobile phone w/o battery (??)	?
P1	2 of 12	Electronic Vaporizers (sani-cigs) - 12 pallets	?
P2	3 OF 3	NiMH batteries	195
P2	1 of 1	Lithium-ion batteries (laptop batteries)	11
P3	4 of 12	Electronic Vaporizers (sani-cigs) - 12 pallets	?
P4	1 of 12	Electronic Vaporizers (sani-cigs) - 12 pallets	?
P7	5 of 12	Electronic Vaporizers (sani-cigs) - 12 pallets	?
P8	13 of 26	Laptop Batteries (various qty/pkg)	?
P9	1 of 1	NiMH batteries	20
P9	6 of 6	NiMH batteries	600
P9	4 of 4	Lithium-polymer batteries and motors for models	122
P9	1 of 1	Lithium-ion batteries	18
P9	8 of 8	Lithium-ion batteries	50
P9	1 of 1	Lithium-polymer batteries	10
P9	1 of 1	Lithium-ion batteries	20
P9	1 of 1	Primary lithium battery	2
P9	1 of 1	Lithium-polymer battery pack	10
P9	1 of 1	Lithium Maganese dioxide battery	50
P9	3 of 3	NiMH batteries	500

**Figure 2 – Items of Interest onboard UPS Flight 6**

In order to obtain further information on these 19 shipments, the Cargo Group requested assistance from the Government of Hong Kong's Civil Aviation Department (HKCAD) and the Civil Aviation Administration of China (CAAC). The group developed a set of questions that a HKCAD or CAAC representative may use when contacting the shippers/freight forwarders of these 19 shipments in an attempt to fill in the missing information and/or verify that the shipments were correctly offered for transportation by air.

***HKCAD and CAAC Responses to Inquiries on Items of Special Interest***

To date, the Cargo Group has received responses to 13 of its 19 inquires. Of these 13 responses, 10 confirmed that the shipments contained lithium batteries; either individually packaged, or contained

in/packed with equipment. Two of the 13 responses revealed that there were no lithium batteries in the shipments, and one of the 13 responses from a freight forwarder indicated that it was uncertain whether their shipment contained lithium batteries (Figure 3).

Item No.	Position	Item Description	Battery Type?	Cell or Battery Pack?	Voltage	Watt-hour rating	Amp-hour rating	Equivalent lithium content	UN Test Report? (Y/N)	Battery Meets UN Standards?	MSDS? (Y/N)
1	1	lithium ion batteries contained in equipment (scanners)	Lithium ion	Battery Packs (P/N(s): B25000005 & B25000006)	3.7V	8.14Wh, 1.1Wh	2.2Ah, 300mAh	0.66g, 0.09g	Y (battery type listed does not match P/N)	Y (battery type listed does not match P/N)	Y (MSDS does not match P/N)
3	4L	battery packed with equipent (marine radios S/N: SR892EUL)	Lithium ion	Battery Pack (M/N: 454169)	7.4V	10.36Wh	1.4Ah	0.42g	Y	Yes, UN 38.3 Test report no. TP20100421 454169	Y
5	5R	laptop power packs	Lithium ion	Battery Packs	various (21 types)	?	various (21 types)	?	N	N	Y
7	6L	lithium polymer batteries - 'lead wires'	Lithium ion	Battery Packs (M/N: AE50100100P4 HE-4S4P)	14.8V	284Wh	19.2Ah	5.76g	Y	Y	Y
8	6R	LiFePO4 batteries for electric vehicle	Lithium ion	Battery Packs (P/N: 9070260, 7070260, 70173248)	48V, 36V, 24V	1056Wh, 972Wh, 480Wh	22Ah, 27Ah, 20Ah	6.6g, 8.1g, 6.0g	N	?	Y (MSDS does not match P/N)
13	10R	LiFePO4 batteries for electric vehicle	Lithium Ion	Battery Packs (P/N: 9070260)	48V	1056Wh	22Ah	6.6g	N	?	Y (MSDS does not match P/N)
15	18R	laptop battery sample	Lithium ion	Battery Packs (P/N: 213282-001)	14.8 V	33 Wh	2.2Ah	0.66g	N	N	Y (Inconsistencies noted)
16	18R	laptop battery sample	Lithium ion	Battery Pack (P/N: 213282-001)	14.8 V	33 Wh	2.2Ah	0.66g	N	N	Y (Inconsistencies noted)
17	18R	calculator batteries	Lithium metal	Coin cells (CR2016 & CR2025)	3V	n/a	n/a	0.03g, 0.05g	Y	Y	Y
18	P1, P3, P4, P7	Lithium-Polymer batteries for electronic vaporizers	Lithium ion	Cells (M/N: M08500P)	3.7 V	0.9 Wh	240 mAh	0.072g	Y	Y	Y

**Figure 3 –Information concerning 10 lithium battery shipments identified from responses received from inquiries about 19 Items of special interest onboard UPS Flight 6**

Of the 10 shipments that contained lithium batteries, nine were lithium ion batteries and one was of the lithium metal variety. According to the information provided by the shippers, three of these nine shipments, Item #7, Item #8, and Item #13, contained lithium ion battery packs with Watt-hour (Wh) ratings significantly greater than 100Wh, which classifies them as Class 9 materials. Accordingly, these shipments should have been shipped as regulated materials per ICAO Technical Instructions, and thus should have appeared on the cargo manifest. Two of these three shipments, Item #7 and Item #8, were located inside containers situated in positions 6L and 6R, respectively; which are located beneath the area of interest due to systems indications on the flight recorders, Item #13 was located at position 10R. The same shipper was responsible for Item #8 and Item #13. While the shipper indicated that testing of the batteries was completed in accordance with UN Standards, no UN Test Report was provided to verify that such tests were completed. Additionally, the MSDS provided did not coincide with the battery model numbers given by the shipper. Further, the product leaflets provided by the shipper do not match the description of the battery types listed on

packing lists and the battery specifications are contradictory to those provided by shipper. The shipper of Item #7 provided UN Tests Reports and MSDS for the batteries in the shipment; all information appeared to be in order.

Some additional discrepancies were noted in the responses received from the shippers of Item #5, Item #15, and Item #16. Each of the shippers' responses indicated that the battery packs they shipped were not tested in accordance with UN Standards; tests which are required. Additionally, several discrepancies were noted in the MSDS provided the shipper of Item #15 and Item #16. Additionally, the shipper of Item #1 provided a UN Test Report and MSDS that did not appear to go with the battery packs contained in the shipment. The information provided by the shippers of the remaining items not discussed appeared to be in order, and the items contained in the shipments were not required to be regulated. All of the information gathered from the responses received has been compiled into a spreadsheet .

#### **G. Lithium Battery Transportation Standards**

Lithium batteries transported in commerce are regulated by both the Department of Transportation (DOT) Hazardous Material Regulations (HMR) and International Civil Aviation Organization Technical Instructions (ICAO TI). Both sets of regulations classify most lithium batteries as DOT Class 9 hazardous materials; however the regulations do except certain shipments of lithium batteries from being shipped as dangerous goods. These exceptions allow some shipments of lithium batteries to be offered for transport without shipping papers, and not subject them to marking and most labeling requirements. Requirements specific to domestic and international shipments are described below.

##### ***International Standards***

International air transportation of lithium batteries must comply with the International Civil Aviation Organization Technical Instructions (ICAO TI). These shipments must be classified, prepared, documented, marked and labeled as specified in the TI. Specific instructions for packaging lithium batteries are located in Part 4 of the ICAO TI (Packing Instructions 965-970). These instructions provide the shipper with specific guidance on how lithium batteries are to be packaged. Each packing instruction is divided up into two sections. Section I provides packing instructions for fully regulated batteries (Class 9). Section II provides the shipper relief from function specific training, shipping paper, specification packaging and labeling requirements if the section II instructions are followed properly. Additionally, column 7 of the ICAO TI Dangerous Goods List refers the shipper to (Part 3, Chapter 3), Special Provisions. The Special Provision section provides the shipper additional guidance and direction for unique shipments of lithium batteries.

The following is an abbreviated version of the ICAO TI packing instructions (965 – 970). These packing instructions are specific to lithium batteries.

- *Packing instruction 965 - Passenger and cargo aircraft for UN 3480*

This entry applies to lithium ion or lithium polymer batteries in Class 9 (Section I) and lithium ion or lithium polymer batteries subject to specific requirements of these instructions (Section II).

- *Packing instruction 966 - Passenger and cargo aircraft for UN 3481 (packed with equipment)*

This entry applies to lithium ion or lithium polymer batteries packed with equipment in Class 9 (Section I) and lithium ion or lithium polymer batteries packed with equipment subject to specific requirements of these Instructions (Section II).

- *Packing Instruction 967 - Passenger and cargo aircraft for UN 3481 (contained in equipment)*

This entry applies to lithium ion or lithium polymer batteries contained in equipment in Class 9 (Section I) and lithium ion or lithium polymer batteries contained in equipment subject to specific requirements of these Instructions (Section II).

- *Packing Instruction 968 - Passenger and cargo aircraft for UN 3090*

This entry applies to lithium metal or lithium alloy batteries in Class 9 (Section I) and lithium metal or lithium alloy batteries subject to specific requirements of these Instructions (Section II).

- *Packing Instruction 969 - Passenger and cargo aircraft for UN 3091 (packed with equipment)*

This entry applies to lithium metal or lithium alloy batteries packed with equipment in Class 9 (Section I) and lithium metal or lithium alloy batteries packed with equipment subject to specific requirements of these Instructions (Section II).

- *Packing Instruction 970 - Passenger and cargo aircraft for UN 3091 (contained in equipment)*

This entry applies to lithium metal or lithium alloy batteries contained in equipment in Class 9 (Section I) and lithium metal or lithium alloy batteries contained in equipment subject to specific requirements of these Instructions (Section II).

### ***Domestic Regulations***

Domestic air transportation of lithium batteries must comply with the HMR. The specific packaging instructions for lithium batteries are found in 49 Code of Federal Regulations (CFR) Part 173.185. Additionally, column 7 of the Hazardous Materials table refers the shipper to Special Provisions found in 49 CFR Part 172.102, which provides additional shipper guidance and direction.

Currently the DOT is proposing to exceed the international regulation requirements for the air transportation of lithium batteries. See Notice of Proposed Rule Making: PHMSA-2009-0095 (HM-224F); Transportation of Lithium Batteries attachment ABC.

### **H. Dangerous Goods Advisory Bulletin**

The Government of Hong Kong's Civil Aviation Department issued a Dangerous Goods Advisory Circular in March 2007. The department's Dangerous Goods Office recognized that many air cargo consignments containing batteries departing Hong Kong International Airport were accompanied with incorrect shipping documentation. This shipping documentation included forged or sub-

standard laboratory certificates and Material Safety Data Sheets (MSDS). The Advisory Circular condemned these actions and described the requirements for transporting batteries as general cargo on aircraft according to the International Civil Aviation Organization (ICAO) Technical Instructions and the International Air Transport Association (IATA) regulations. The Advisory Circular requested that freight forwarders and airlines exercise due diligence in verifying that laboratory certificates and/or MSDS submitted for the batteries are reasonable and logical. It also encouraged freight forwarders and airlines to cooperate and exchange information regarding mis-declaration of dangerous goods.

The cargo group has requested a status update on this safety issue from the Hong Kong Civil Aviation Department as part of its investigation.

**I. UN Sub-Committee of Experts on the Transportation of Dangerous Goods**

Provisions for the transport of lithium batteries are considered by a number of international bodies including the United Nations Sub-Committee of Experts on the Transport of Dangerous Goods (UN Sub-Committee). The UN Sub-Committee publishes model regulations which are incorporated into international and domestic standards world-wide, including the ICAO Technical Instructions for the Safe Transport of Dangerous Goods by Air and the International Maritime Dangerous Goods Code which cover the vast majority of international air and sea shipments.

Prior to its current work cycle, the UN Sub-Committee adopted a number of amendments relative to the packaging and hazard communication requirements for lithium batteries. With this work considered largely complete, the sub-committee shifted its focus to modernizing the design-type testing requirements for such batteries. These test methods, contained in the UN Manual of Tests and Criteria, are designed to ensure the integrity and safety of the battery. During its current working biennium (2009-2010), the UN Sub-Committee convened an intercessional working group which met to consider revisions to the current design type test methods applicable to lithium batteries. Many of these revisions are intended to address emerging battery technologies; for example large format lithium batteries used in hybrid/electric vehicles. The U.S. participated actively in this meeting, as did a number of other UN Sub-Committee members and observers. The resulting recommendations made by the working group have been submitted for consideration by the UN Sub-Committee at its upcoming session scheduled to be held November 29-December 7, 2010.

**J. History of Lithium Battery Accidents in the Aviation Industry**

Since the UPS Flight 1307 onboard fire occurred in February 7, 2006 [NTSB Report No. AAR-07-07] there have been 34 battery and battery-powered devices aviation incidents reported to the Federal Aviation Administration (FAA) involving batteries that involved smoke, fire, extreme heat or explosion. Approximately 22 of these aviation incidents involved lithium-ion batteries, with 14 of these incidents having resulted in an actual fire. The remaining 12 aviation incidents involved lithium-metal batteries, with eight of these incidents having resulted in an actual fire. Attachment

13 contains the entire battery incident chart, which is maintained by the FAA. This chart dates back to March 20, 1991.

**K. HAZMAT Intel Portal (HIP)**

The HAZMAT Intelligence Portal (HIP) is a web-based hazardous materials intelligence data warehouse that provides centralized access to information to support risk management, transparency, and decision support objectives for several modal sources. The following modal agencies contribute data to the system:

- PHMSA: Pipeline and Hazardous Materials Safety Administration
- FMCSA: Federal Motor Carrier Safety Administration
- FRA: Federal Railroad Administration
- FAA: Federal Aviation Administration
- USCG: US Coast Guard
- EPA: Environmental Protection Agency
- ATSDR: Agency for Toxic Substances and Disease Registry Division of the CDC

Company data, including names and addresses, are provided by modal agencies and indexed in the Master Company Hub. The Master Company Hub aggregates company data from many sources. The company data is sent to Dun and Bradstreet (D&B) for their initial matching and cleansing service on a weekly basis. If the company data matches D&B data, then D&B returns the name and address and the Master Company Hub assigns a number as the unique identification for that facility. On a quarterly basis, the Master Company Hub initiates another transaction to update the complete set of 90 plus data fields, including US parent company, financial data, and demographic data, is refreshed. If a D&B match is not found, then the Master Company Hub stores that company with the original source data. This usually results in only that single transaction or transactions from a single source being associated to that unmatched facility.

There are almost 10,000 companies that meet the criteria of PHMSA's National Business Strategy. PHMSA conducts operations based on a data-driven risk-based National Business Strategy, which identifies the level of priorities and risk factors. Daily Ranking Report in HIP prioritizes company rankings based on a systematic algorithm. This algorithm is based on National Business Strategy's priorities and risk factors. By using HIP, PHMSA was able to create a report that used these factors in ranking companies in HIP. The report is refreshed on a daily basis, providing PHMSA's investigators with a list of companies that meet the criteria of inspection priorities.

The following is the National Business Strategy Priority Definition:

- DARK RED – Maximum Priority Accident and Incident Investigations; Failure analysis/investigations; Complaints,
- RED – High Priority Serious incidents (non-bulk and intermediate bulk); Incidents involving TIH, Class 1, Class 7, PG I and Aircraft; Large package quantity (not cargo tank or tank cars)

Chlorine and other Div 2.3 and 6.1 PG I shippers; Fitness reviews; PHMSA verified undeclared shipments,

- **ORANGE** – Medium Priority Abatements; High Incident Frequency (> 10 in 3 years); High certification markings reported by the third party laboratories; UN Non-bulk, Intermediate Bulk Package, Inter-modal tank, and Cylinder Manufacturers, Package Self-certifiers and re-manufacturers; Third Party Certification Agencies; Package Rebuilders and Re-conditioners; Re-inspections,
- **YELLOW** – Priority FAA repair stations and secondary shippers (O2 generators); Nurse tank and Propane Special Permit Holders (13554 and 13341); Entities and previous registrants prior notified of registration requirements w/o response; Never Inspected High Pressure and Acetylene Cylinder Requalifiers; High Hazard Registered Entities or Shippers (TIH, Class 1 or Class 7); Flagged Registration Entities, Select Agent Shippers; Joint Agency Enforcement Activity in PHH jurisdictional area.

HIP houses more than 40 Million records with activities, some of them being incident-related data. The incident data in the HIP comes from multiple sources: 5800 reports, National Response Center Telephonics, Unreported Incidents and Agency for Toxic Substances and Disease Registry. HIP collects the information for management and analysis, so that the data can be used at all levels with knowledge and insight for better decision-making. PHMSA uses incident data to help assess and manage risk surrounding the transportation of hazardous materials. To this end, incident data is used in a variety of ways such as identifying hazardous materials trends, statics for regulatory evaluations and rulemakings, and providing focus areas for field operation inspections and investigations. Recent incident data is also being used as one facet of evaluating a company's level of fitness when applying for a special permit or approval.

HIP also houses over 2 million company records, which includes both domestic and international companies. All the companies in the HIP are validated against D&B's database. Up until now, PHMSA's contract with D&B has been with only the domestic companies. This allowed for HIP to provide the user groups with company information such as the DUNS#, demographics data, revenues data, and etc. However, PHMSA has just entered a new agreement with D&B that will be in effect in the upcoming months that will allow for the same type of validation for certain International companies (Canada, Mexico, Puerto Rico and China).

#### **L. Shipper History**

The Cargo Group used HIP to determine the number of special permit/approval, incidents and inspections associated with the shippers/freight forwarders listed on the shipping documentation from UPS Flight 6. It was determined that both *A & A Worldwide International* and the *U.S. Air Force*, which were both listed on the shipping documentation for UPS Flight 6, had incidents listed in HIP. None of the other shippers/freight forwarders listed on the shipping documentation were involved in an incident or issued a special permit/approval. Furthermore, no compliance inspections were conducted for the shippers/freight forwarders listed on the shipping documentation.

**M. UPS Procedures for Accepting Shipments**

All Air Cargo procedures are documented in the UPSCO Cargo Handling Procedures Manual in its current revision. All shipments accepted from a Pre-Built Shipper or Container Freight Station is required to comply with UPSCO Cargo Handling Procedures Manual. These procedures are referenced in Chapter 1 (pages 41 and 42) and Chapter 2 (page 51).

The required training certifications for a Container Freight Station and/or Pre-built shipper for UPS movement consist of ULD Serviceability, Build-Up, Shoring, Dangerous Goods Acceptance and/or Dangerous Goods Recognize and Reject. All training completed must be performed by a certified UPS Corporate Air Trainer/Cargo Specialist prior to shipment acceptance.

Freight Forwarders are required to have an approved and current contract to move Dangerous Goods within the UPS Network. All dangerous goods must be tendered loose to a certified dangerous goods acceptance location. UPS Air Cargo does not accept dangerous goods from Pre-Built shippers. UPSCO training is documented and audited per the UPSCO National Air Audit (I-b-2, 1b-3-a &b, I-b-4-a&b).

Regardless of build up method, all shipments accepted and moving on UPSCO comply with the guidelines outlined in the UPSCO Cargo Handling Procedures Manual.

**N. Audits of Hong Kong and Dubai Facilities**

***UPS***

The UPS Air Audit Department conducts audits of UPS Gateway Operations as part of the company's Internal Evaluation Program for Continuous Analysis Surveillance System (CASS). Adherence to the process and procedure contained in the CASS allows involved personnel to perform their duties and responsibilities with a high degree of safety.

Audits were conducted on both the Dubai and Hong Kong Facilities in April 2009, and March 2010, respectively. As a result of these audits the UPS facilities in Dubai and Hong Kong received regulatory compliance ratings of 98% and 99%, respectively, both passing scores. Please refer to Attachments 17 and 18 for further information on these audits.

***Federal Aviation Administration***

The Federal Aviation Administration does not conduct hazardous materials inspections in international locations.

**SEE ATTACHMENTS 19 - 20**



## B: OXYGEN MASK AND OXYGEN HOSE TESTING AT ELEVATED TEMPERATURES

### Oxygen mask and oxygen hose testing at elevated temperatures

Federal Aviation Administration Test Facility,  
Atlantic City, NJ  
Dec 01-02 2011

#### **SYSTEMS GROUP**

The systems group was composed of representatives from the following organizations:

- NTSB, Washington, DC
- GCAA, AAIS [IIC], United Arab Emirates
- Federal Aviation Administration, Atlantic City, NJ
- Intertechnique/Zodiac Aerospace, Plaisir, France
- The Boeing Company, Long Beach, CA
- The Boeing Company, Everett, WA
- United Parcel Service, Louisville, KY
- Independent Pilots Association, Louisville, KY

#### **BACKGROUND**

The CVR investigation indicated that the Captain's oxygen mask stopped delivering oxygen approximately 6 minutes after the fire alarm was heard. The F/O's oxygen supply continued to function when the LH or Captain's supply abruptly stopped with no prior indication of an oxygen supply problem recorded.

The systems group performed an oxygen systems architecture investigation analyzing the oxygen supply routing from the forward cargo hold through to the distribution networks and the final stage of the oxygen delivery to the crew's oxygen stowage box and masks

The crew, and in particular the Captains oxygen supply is routed under the cockpit floor, the Captain's supplementary oxygen supply line runs transversely from the RH side to the LH side of the cockpit, which positions the supply line tubing above a fire on the main deck cargo hold at Body Station 340

The systems group concluded that it may have been possible that elevated temperatures affected the oxygen delivery to the MXP147-3 oxygen mask stowage box and caused a failure on the oxygen system supply.

It was concluded that this was not a supposition that could be rigorously determined through theoretical thermal analysis modeling only and that the key components of the oxygen delivery system would need to be replicated in a controlled environment and tested with super-heated air. [insert superheated definition]

The team convened at the FAA Technical Center, Atlantic City International Airport, on Dec 1-2 2012 to perform elevated temperature testing of the oxygen delivery system and the associated mask function performance.

## **TEST OBJECTIVES**

1. To determine if elevated temperatures in the supplementary oxygen supply has a detrimental effect of the functioning of the oxygen mask.
2. To observe any other anomalies in the supplementary oxygen supply system at elevated temperatures
3. Determine the Mask Function/Operation at Reduced Pressure
4. Determine what the effect on the oxygen supply could result from a pressure loss when there is a single 60B50059 hose failure

## **METHODOLOGY**

A test rig was designed and assembled to represent the B747 oxygen system in the area of the flight deck.

The system was an open loop pressure fed representative airplane system, however, dry compressed air was used instead of pure oxygen for safety purposes.

The air supply was routed through a variable temperature furnace capable of replicating the temperatures of a cargo fire of between 1000-1400°F/538-760°C

Compressed air was introduced into the system<sup>100</sup>; the air was heated to representative thermal load levels in the furnace and then delivered through a CRES tube connected by the design standard flexible hose (part number 60B50059) used on the B744F. Downstream, the flexible hose was connected to the MXP147 mask stowage box, and then through the DTS4032 flexible hose to the mask.

The mask air volume exchange was supplied via a Simulated Breathing Device [SBD]

The SBD consisted of a programmed stepper motor which operated a linear drive mechanism attached to a piston in an air cylinder. The outlet of the air cylinder was connected by copper pipe to the mouth of a mannequin head.

To secure the MC10-25-104 oxygen mask with the oval cavity, additional silicone sealant was applied to represent a full fit, form and function seal between the anterior, ventral, aspect of the head from the forehead to the chin and the oxygen mask.

---

<sup>100</sup> Refer to the Test Rig Diagram/Schematic

## TEST RIG MANNEQUIN TECHNICAL SPECIFICATIONS

The simulated breathing device was set as follows:

Stroke length 3.84 inches

Piston diameter – 4.5 inches

Inspiration time – 1.3 seconds

Expiration time – 2.2 seconds

Volume exchange each cycle is approximately 61 cubic inches or 1 liter, with a cycle of 17 respirations per minute.<sup>101</sup>

## MASKS USED DURING THE TESTING

Zodiac Aerospace/Intertechnique Aircraft Systems produced three masks with part numbers MC10-25-104.

Each mask was assembled to the same production modification specification of the type used on the accident airplane.

The associated Mask Stowage Box [MSB] part number MXP147-3 was also supplied to specification.

These were the masks/MSB's used in this mask functional testing

Information on the Mask Stowage Box:

A. A mask stowage box is located at each crew station.

B. The box provides stowage for the mask/regulator and controls flow of oxygen to the mask/regulator.

The box contains a sliding control, a shutoff valve, left and right lids and a flow blinker. The box also has a pressure switch which activates the microphone in the mask.

C. The sliding control/Reset Test Switch automatically keeps the shutoff valve in the closed position when the mask/ regulator is stowed and both lids are closed.

Holding the sliding control in 'TEST' allows the mask/regulator to be tested when in the stowed position. The inner part of the sliding control has a white flag marked OXY-ON.

D. The left lid controls the shutoff valve when the mask/regulator is removed from the box. The left lid also moves the sliding control's white flag to the exposed position when the mask/regulator is removed and the left lid is closed.

E. The flow blinker contains a yellow diaphragm and a black diaphragm. When oxygen flow occurs, the yellow diaphragm is pushed up against the black diaphragm causing a yellow cross to appear. During oxygen flow a yellow cross appears on the flow blinker on the mask stowage box. During no flow conditions, the flow blinker is all black.

---

<sup>101</sup> Average respiratory rate reported in a healthy adult at rest is usually given as 12-18 breaths per minute

### Test Rig Diagram/Schematic

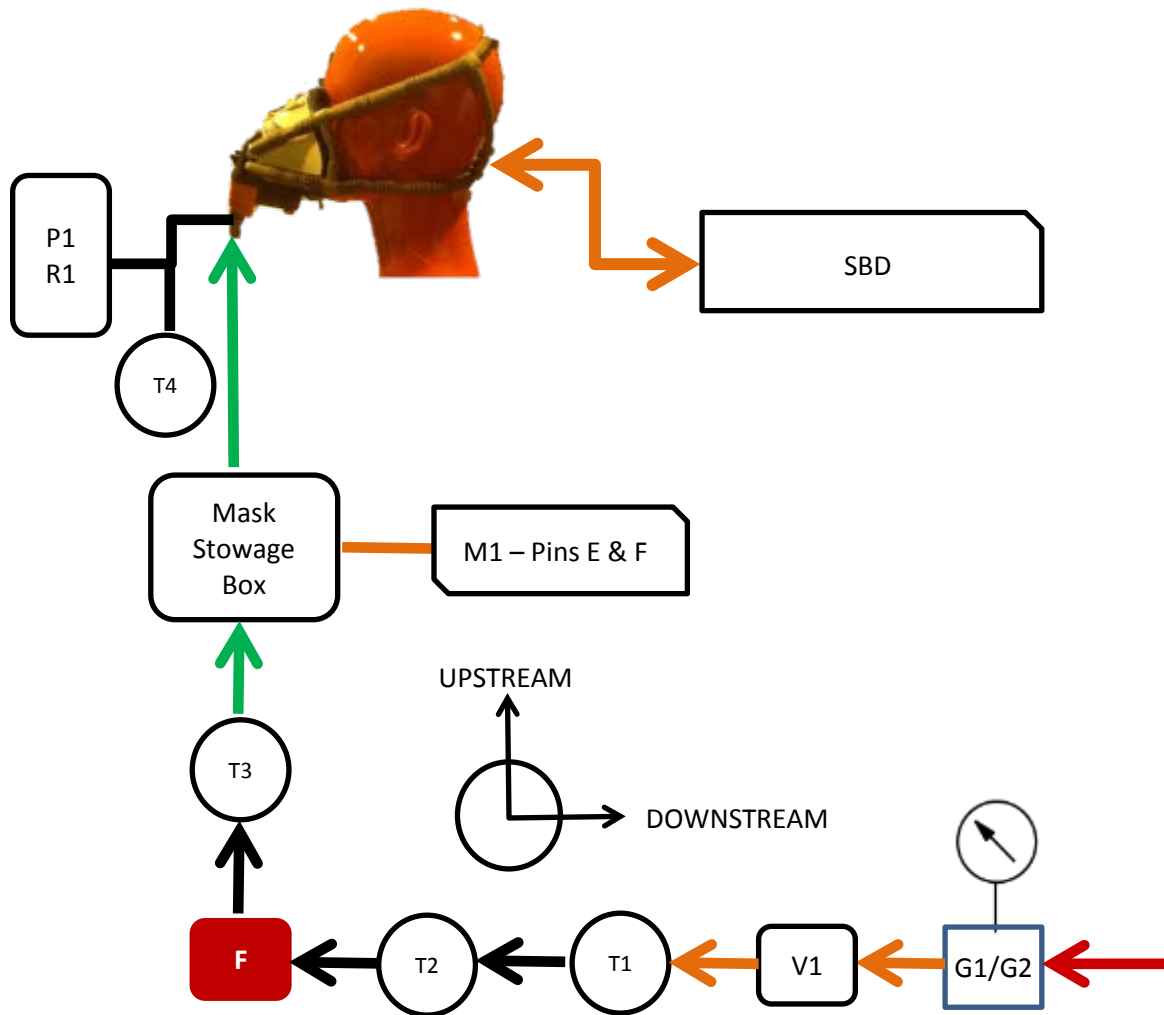

#### DRAWING KEY:

- 3/8" CRES Tube
- Oxygen Hose 60B50059
- Oxygen Supply Hose DTS4032
- 3/8" Copper Tube
- Flexible Hose

F1	Furnace	SBD	Simulated breathing Device
G1	Pressure Gauge	T1	Thermocouple
G2	Pressure Gauge	T2	Thermocouple
M1	Multimeter Resistance	T3	Thermocouple
P1	Manometer	T4	Thermocouple
R1	Relief Valve	V1	Shut Off Valve

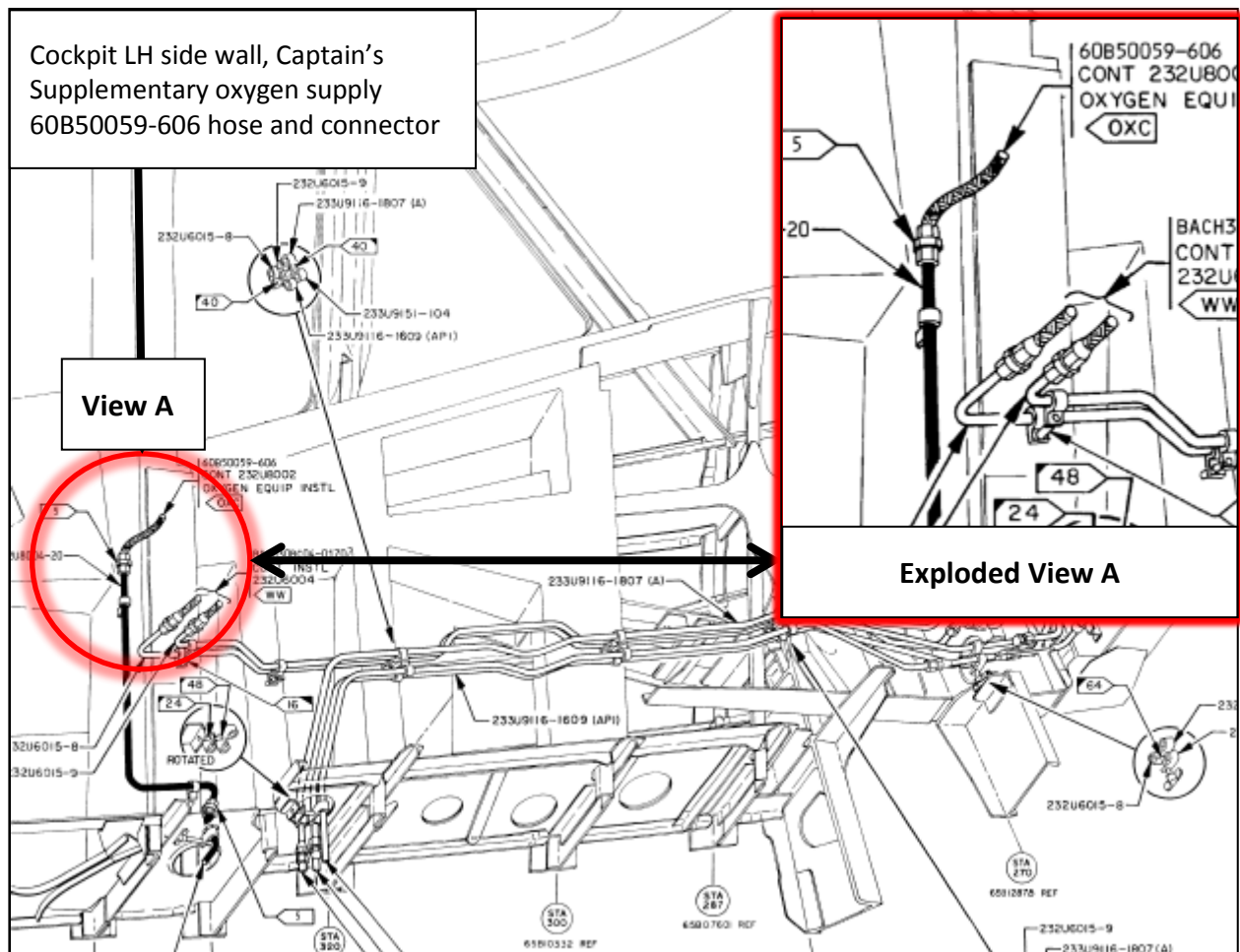

Figure 61 - View on cockpit LH sidewall - Captains supplementary oxygen supply hose and connector

Dimensions of the tubing lengths were as follows:

- V1 to furnace – 33"
- Inside furnace – 100"
- Furnace to flex hose – 12" insulated, 7" uninsulated
- 60B50059 hose – 30" (test 1 and 2), 12" (test 3)
- DTS4032 – 60"
- The tube used was 3/8 inch steel tube with an 0.0375" wall thickness.

SBD volume exchange and repetition

- Volume exchange each cycle was approximately 1 liter [1.0 L]
- Exchange rate was 17 respirations per minute.

## PRE-TEST CALIBRATION VALUES

<b>Parameter</b>	<b>Value</b>
Confirm G1 = 135 Psi	130
Confirm G2 = 60-80 Psi	74
Confirm M1 F-E open	out of range high
Confirm M1 F-E closed	0 ohms
Record manometer reading P1	0.5
Place mask in Normal	
Record P1	0.5
Place mask to 100% and Emergency and open vent	
Record P1	2.0
Close V1	
Record P1	15.5
Place mask in 100%	
Record P1	15.5
Place mask in Normal	
Record P1	7
Open V1	
Inflate mask harness and remove from breathing simulator.	
Block simulator oval oral cavity opening during inspiration.	
Observe relief valve operation.	
Record P1	15.5

Calibration and function tests were completed and verified.

## OXYGEN MASK ELEVATED TEMPERATURE TEST 1

### TEST 1

Mask used PN MC10-25-104, Serial # 150749

Mask Box – PN MXP147-3, SE46452

PVC Hose – PN 60B50059

The thermocouple values were recorded at a sample rate of 1 per second

1. Mask configuration: selector set to the 100% position
2. T2 Furnace temperature: 1000F
3. Open V1
4. Activate SBD
5. If flex hose leaks or P1 exceeds 4, go to failure scenarios

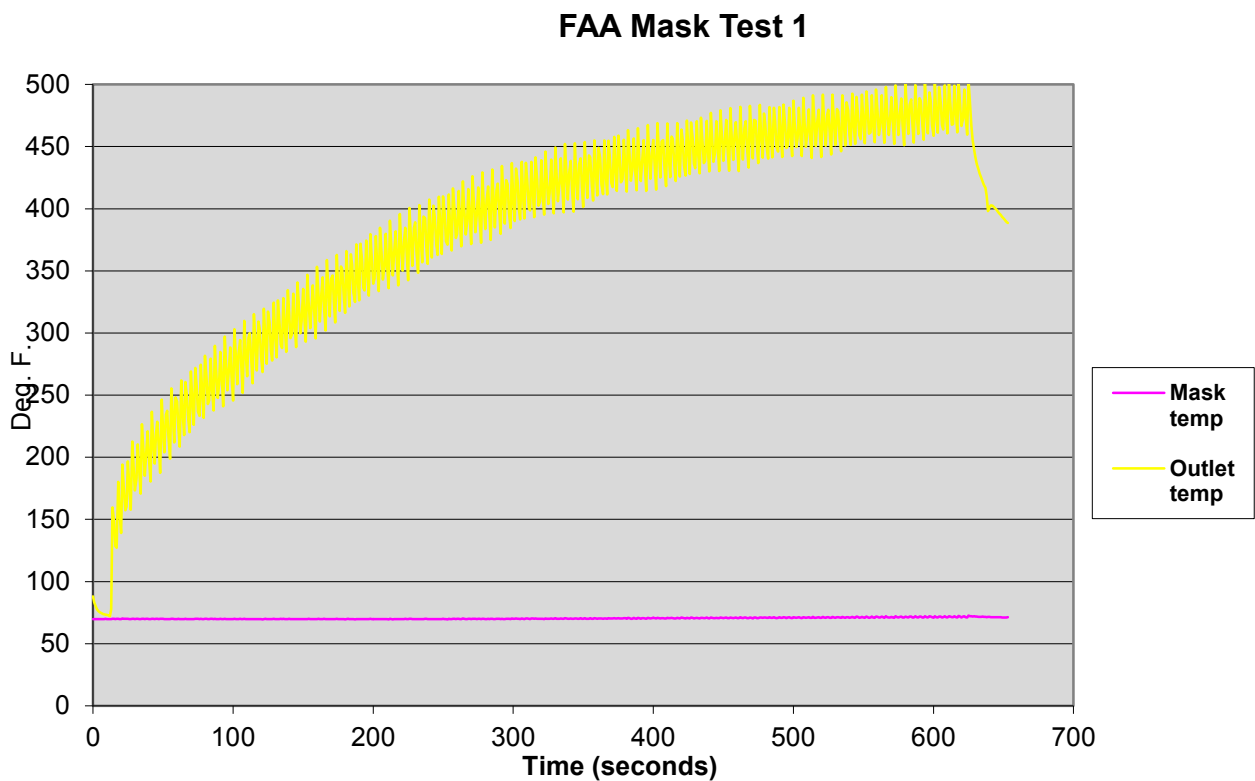

Thermocouple Temperature values at the termination of Test 1

Mask	T1	T2	T3	T4
Delivery	64.2F	1038.03F	388.62F	71.27F
Temps	17.88C	558.8C	198.1C	21.81C

**Observation:** Test was completed with no system or mask failures.

## OXYGEN MASK ELEVATED TEMPERATURE TEST 2

Mask used: part number MC10-25-104, Serial # 150749  
Mask Box: part number MXP147-3, SE46452  
PVC Hose – PN 60B50059

The thermocouple values were recorded at a sample rate of 1 per second

1. Mask configuration: Selector set to 100% + EMERGENCY/Open vent
2. T2 Furnace temperature: 1000F
3. Open V1
4. Activate SBD
5. If flex hose leaks or P1 exceeds 4, go to failure scenarios.

**Observations/Results:**

- i SBD on at: 12:14:50 [Local]
- ii Initially the mask operated as expected.
- iii As the IR camera indicated the progression of the heated air and the heating of the tubing, a fissure in the 60B50059 hose was detected at the T3 junction of the 3/8” CRES/60B50059 oxygen hose connector coupling joint, followed by an detectable increase in the size of the fissure downstream from the CRES/60B50059 hose connector as the heated air flow increased.
- iv Flex hose 60B50059 failed at 12:21:20 [Local]
- v The manometer reading went above the 4 inches of water limit cut off and the test was discontinued.

**Failure Summary:**

- Elapsed time between starting and the hose failure was: **7min 30 sec**
- Failure of the 60B50059 hose fitting between the CRES connector and the Mask Stowage Box.
- White smoke was observed to be emanating the mask. The mask was removed and secured for further detailed examination with the mask manufacturer.

Thermocouple temperature values at the termination of Test 2

	T1	T2	T3	T4
Mask Delivery	67.41F	1042.7F	720.4F	72.56F
Temps	18C	561.5C	382.2C	21.81C



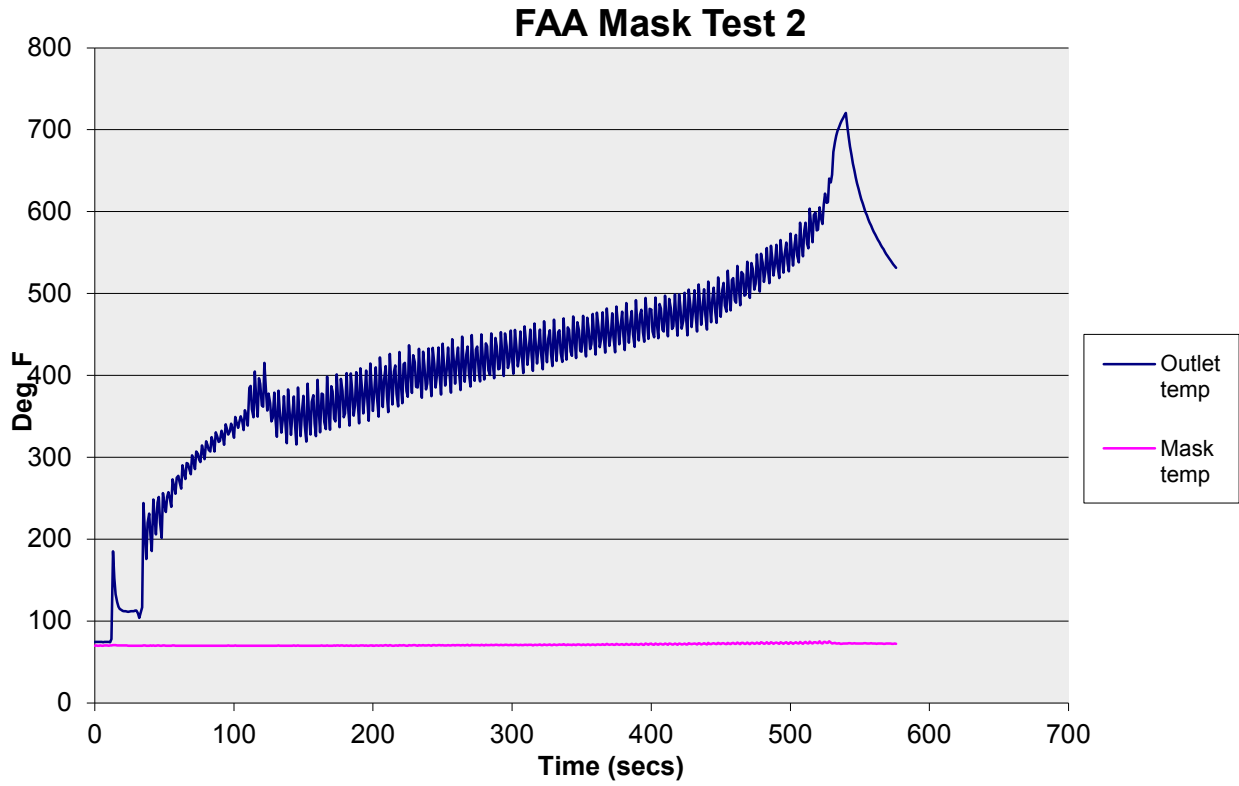

**Mask Test #2 Flex Hose 60B50059 hose failure**

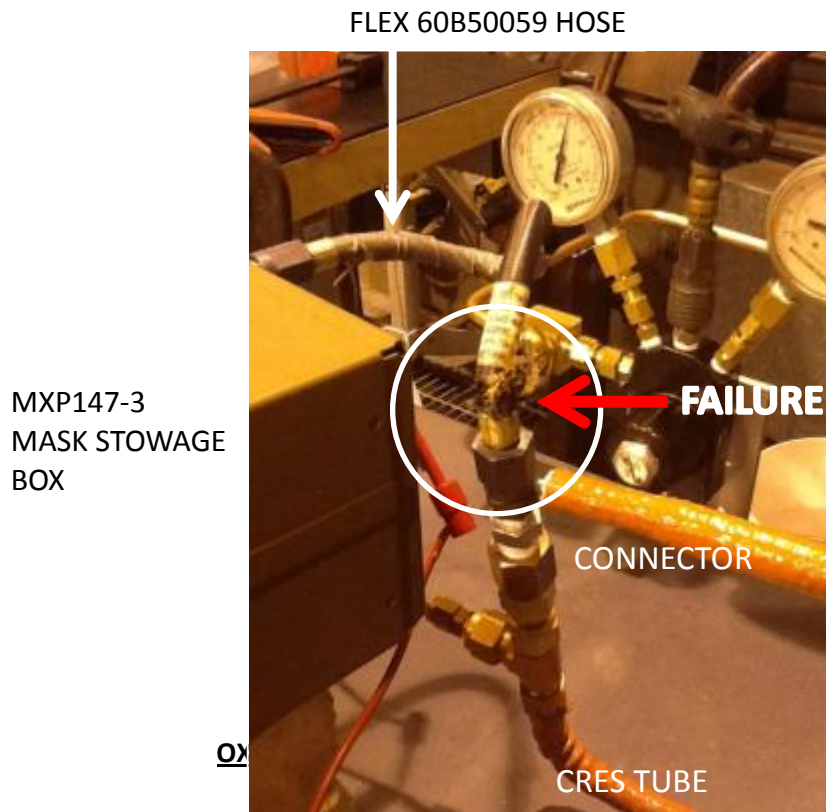

Mask used part number MC10-25-104, Serial # 150750

Mask Box – Part number MXP147-3, SE47315

PVC Hose – PN 60B50059

The thermocouple values were recorded at a sample rate of 1 per second

1. Mask configuration: Put selector into the 100%
2. T2 Furnace temperature: 1400F
3. Open V1
4. Activate SBD
5. If flex hose leaks or P1 exceeds 4, go to failure scenarios

- SBD on at: 14:31:10 [Local]
- Flex hose 60B50059 failed at:
  - Smoke detected: 14:35:27 [Local]
  - Leak detected: 14:35:40 [Local]
  - MXP147 pressure switch tripped: 14:40:45 [Local]

Elapsed time from turning on the SBD until the leak was detected: **4min 30 sec**

**Failure Summary:**

- A failure of the 60B50059 hose occurred near the fitting downstream from the metallic collar of the CRES to flex hose connector.
- Approximately 5 seconds after the initial hose failure the manometer reading went well above the 4 inches of water limit and the test was discontinued.
- The pressure switch went open within a second of the manometer reading above the 4 inches limit
- White smoke was observed emanating from the mask.
- The mask was removed and secured for further examination.

### FAA Mask Test 3

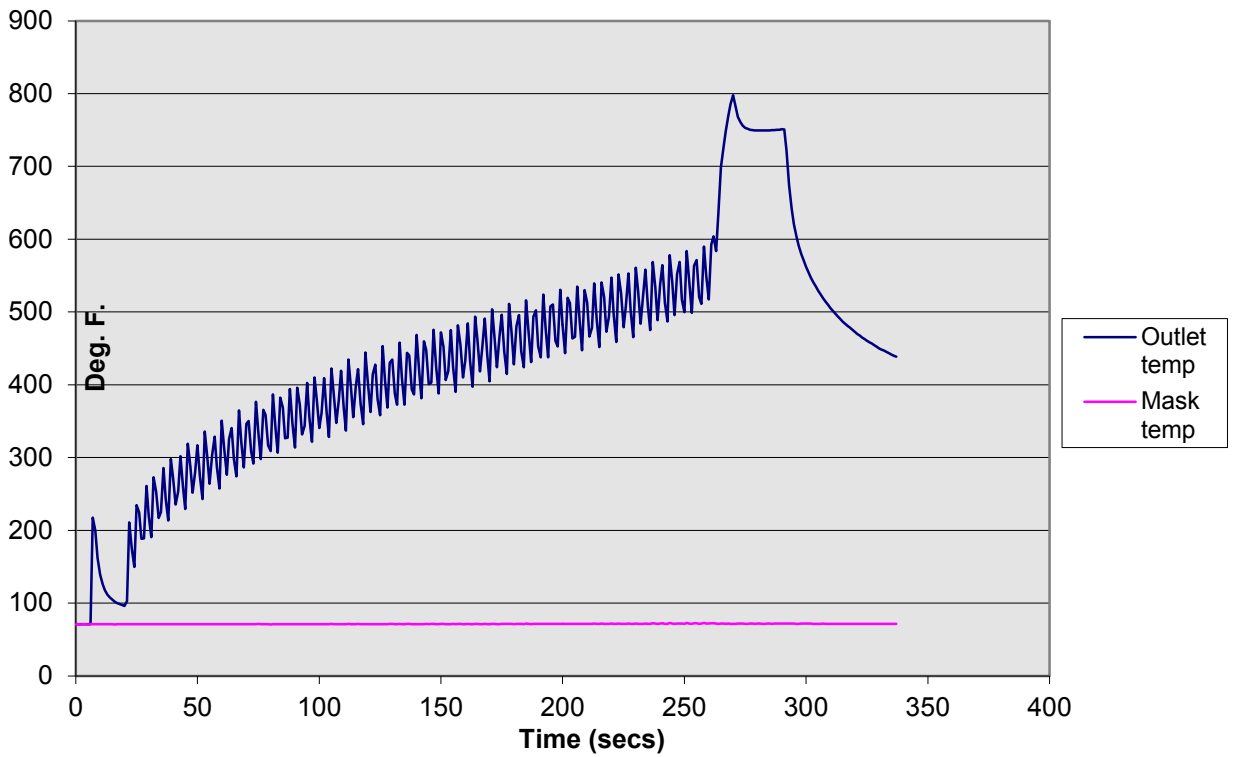

Mask Test #3 Flex Hose 60B50059 hose failure

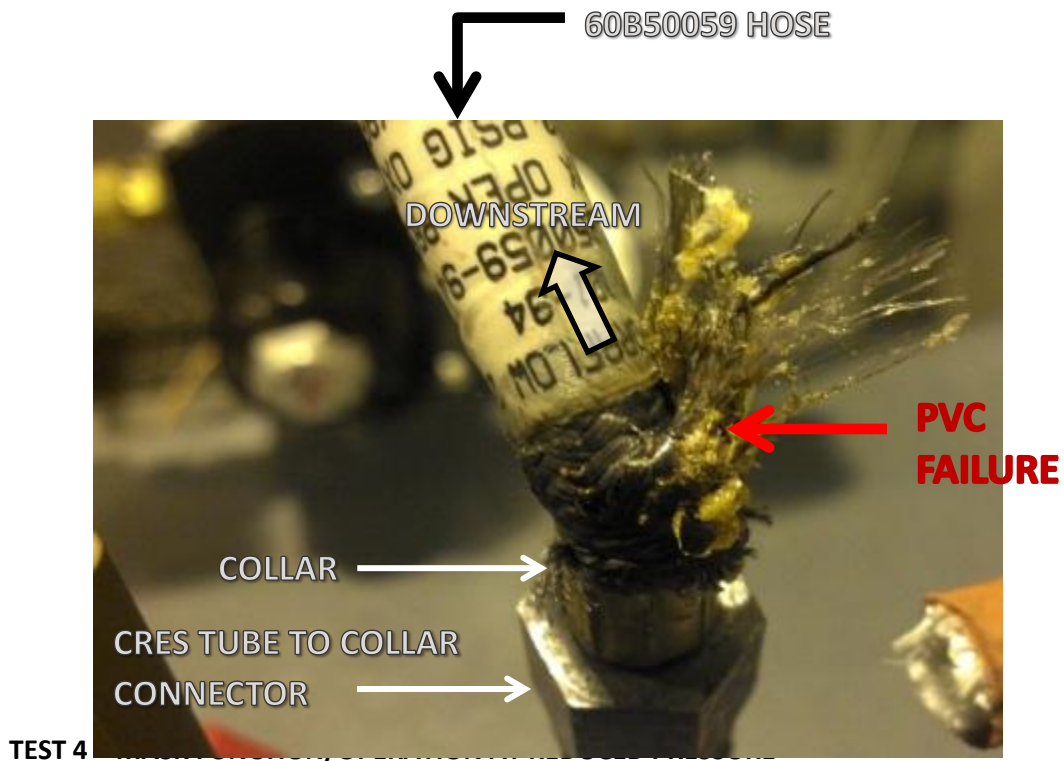

**Objective:**

A test was performed to determine how the mask and pressure switches behaved as the pressure to the mask box was slowly reduced.

**Observations:**

- It was found that the force required to inspire through the mask increased as the pressure was reduced to between 30 – 40 psi.
- At approximately 25 psi and lower it was considered difficult to continue normal at rest breathing.
- The pressure switch did not change state until the pressure was reduced to approximately 14 psi.

**TEST 5 - PRESSURE LOSS WHEN A SINGLE 60B50059 HOSE FAILURE**

**Objective:**

A test was performed to determine the amount of pressure loss at the output of the Airplane Regulator with a failed 60B50059 hose.

This test was performed in order to determine if there would be pressure at the first officers oxygen mask to operate.

This test was performed with the failed Test 3 60B50059 hose with the furnace turned off.

**Observation:**

- The pressure at the output of the regulator showed 62 psi with the damaged 60B50059 hose venting through the damaged section.

Conclusion – the FO mask would continue to function for an unspecified, but finite time, as the venting supplementary oxygen levels decreased.

C: ZODIAC MASK TESTING

	<p><b>DEVELOPMENT WORKSHOP</b></p> <p><b>TEST RESULT</b></p> <p><b>4RE12026</b></p> <p><b>ISSUE 1</b></p>	<p><b>OXYGEN</b></p> <p><b>SYSTEMS DIVISION</b></p>
---	---	---

Test title :	Test with two oxygen masks MC10-25-104 and MXP147-3 stowage boxes (UPS)
--------------	---

Table of contents

<b>1. INTRODUCTION .....</b>	<b>230</b>
<b>2. DEFINITION OF TEST CONDITIONS .....</b>	<b>230</b>
<b>3. TEST SET UP .....</b>	<b>231</b>
<b>4. RESULTS :.....</b>	<b>234</b>
4.1. HARNESS INFLATION : .....	234
4.1.1. Mask S/N 150749 :.....	234
4.1.2. Mask S/N 150750 :.....	234
4.1.3. Inflation test results :.....	235
4.2. BREATHING SEQUENCES : 15 X 1 LITER.....	235
4.2.1. Recording.....	235
4.2.2. Respiratory cycle résultats:.....	237
4.3. PRESSURE SWITCH ACTIVATION AND DE-ACTIVATION : .....	237
4.3.1. Recording.....	238
4.3.2. Pressure switch activation and de activation results.....	238
<b>5. CONCLUSION .....</b>	<b>238</b>

ILLUSTRATION TABLE

<b><u>FIGURE 1 : PRINCIPLE SCHEME FOR OXYGEN REGULATOR .....</u></b>	<b>231</b>
<b><u>FIGURE 2 : SCHEME FOR MC10-25-104 COMFORT TEST SET-UP.....</u></b>	<b>232</b>
<b><u>FIGURE 3 : PHOTO OF MC10-25-104 COMFORT TEST SET-UP.....</u></b>	<b>233</b>
<b><u>FIGURE 4: SCHEME FOR MXP147-3 PRESSURE SWITCH ACTUATION TEST SET-UP .....</u></b>	<b>233</b>
<b><u>FIGURE 5 : PHOTO OF MXP147-3 PRESSURE SWITCH ACTUATION TEST SET-UP .....</u></b>	<b>234</b>
<b><u>FIGURE 6 INFLATION TEST MASK 150749 .....</u></b>	<b>234</b>
<b><u>FIGURE 7 INFLATION TEST MASK 150750 .....</u></b>	<b>235</b>
<b><u>FIGURE 8 : RESPIRATORY CYCLE 100% POSITION .....</u></b>	<b>236</b>
<b><u>FIGURE 9 : RESPIRATORY CYCLE EMERGENCY POSITION .....</u></b>	<b>236</b>
<b><u>FIGURE 10 RESPIRATORY CYCLE 100% POSITION .....</u></b>	<b>236</b>

**FIGURE 11 : RESPIRATORY CYCLE EMERGENCY POSITION .....237**  
**FIGURE 12 : PHOTO OF 098869 TEST BENCH.....237**  
**FIGURE 12 : PRESSURE SWITCH ACTIVATION AND DE ACTIVATION .....238**

**INTRODUCTION**

This document is the Test Report of the expertise of two oxygen masks MC10-25-104 and two stowage boxes MXP147-3 brought to us by the GCAA.

These products have been used by NTSB for furnace tests on the upstream line of the mask and stowage box. Purpose of the tests performed at INTERTECHNIQUE is to state if performance of our equipment was affected by these furnace tests.

**Definition of test CONDITIONS**

**Test room environmental parameters**

Unless otherwise specified, the tests will be performed at ambient temperature and pressure (ATPD):

	Minimum	Maximum
Temperature (°C):	19°C	21° C
Atmospheric pressure (mbar)::	950	1050 mbar
Hygrometry	30 %HC	90 %HC

**Test benches, tools and measuring instruments**

Identification	IN code	Measurement range	Accuracy	Calibration validity date
Air	-	-	-	-
Respiratory pump	-	-	-	-
Black head tool	-	-	-	-
Pressure gauge	OP1914	+/-30 mbar rel	1% of full scale	11/12
Pressure gauge	LO1041	10 bar rel	1% of full scale	10/12
NI USB -6212	-	-	-	-
PC INPLA 0650	-	-	-	-
Pressure gauge	-	+/- 2 mbar	1% of full scale	10/12
Pneumotachograph	IN07308	0-150 l/min	-	03/12
Capacity	-	-	-	-
Recorder	-	-	-	04/12
Pressure gauge	LO1040	10 bar rel	1% of full scale	01/13
Electric supply	IN04033	0-30 volts	-	03/14
Divisor of tension	-	-	-	-

Products or samples under test:

Identification	PNR	SER	Date of Manufacturing
Oxygen Mask regulator	MC10-25-104	150749	-

Oxygen Mask regulator	MC10-25-104	150750	-
Storage box	MXP147-3	SE46452	-
Storage box	MXP147-3	SE47315	-

## TEST PROCEDURES

Note : As we cannot state that our masks have not been polluted by burning particles during previous furnace tests, first verification tests are made with a dry air supply to prevent any risk of fire.

Additional tests can be performed using oxygen, once state of pollution is checked.

### MC10-25-104 quick donning mask

Below are the steps followed to verify functionality of the quick donning mask :

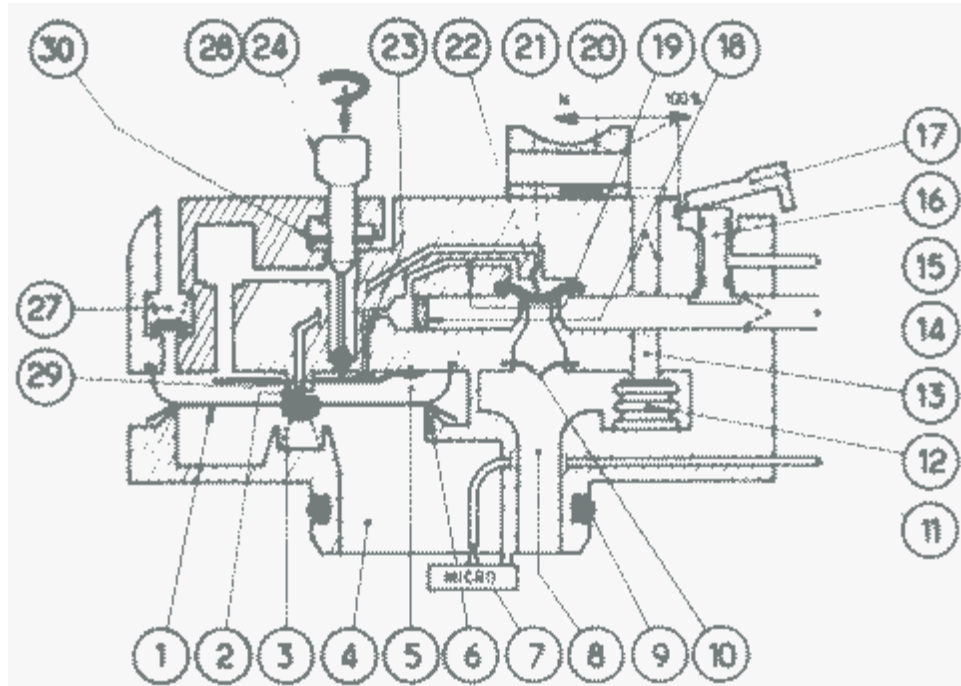

Figure 62 : Principle scheme for oxygen regulator

### Harness inflation operation

The harness inflation is the closest feature from the oxygen supply. It is theoretically the first affected element in case of pollution. Checking that harness inflation time is correct gives the indication that the oxygen supply of the regulator is not severely obtured.

- i. Plug mask hose on 5 bar pressure supply (valve closed)
- ii. Press harness inflation tab (item 17 in figure 1)
- iii. Open 5 bar pressure supply
- iv. Check on screen that pression stabilization time is less than 1 s

### Regulator main membrane closing time (between 0.95 s and 1.30 s)

Main membrane (item 22 in figure 1) moves depending differential pressure in several chambers in the oxygen regulator. Circuits 19, 21 and 23 in figure 2 make the communication between these chambers. These small tubes are pinched to adjust oxygen flow inside the regulator. These adjustments define the response time of a regulator. Checking that response

time is correct gives us the indication that no pollution affected these thin tubes, and hence regulator main function.

- i. Plug mask hose on 5 bar pressure supply
- ii. Measure closing time

### Breathing sequence – 100% mode

This test (in addition to previous closing time test) shows if regulator membranes properly close and open, in 100% oxygen breathing mode.

- i. Plug mask hose
- ii. Commute regulator to 100% mode
- iii. Plug mask hose on 5 bar pressure supply
- iv. Place mask on breathing device
- v. Record several inspiration – exhalation sequences
- vi. Record close time and pressure
- vii. Measure closing time

### Breathing sequence – Emergency mode

- i. Commute regulator to 100% mode + Emergency
- ii. Plug mask hose on 5 bar pressure supply
- iii. Place mask on breathing device
- iv. Record several inspiration – exhalation sequences

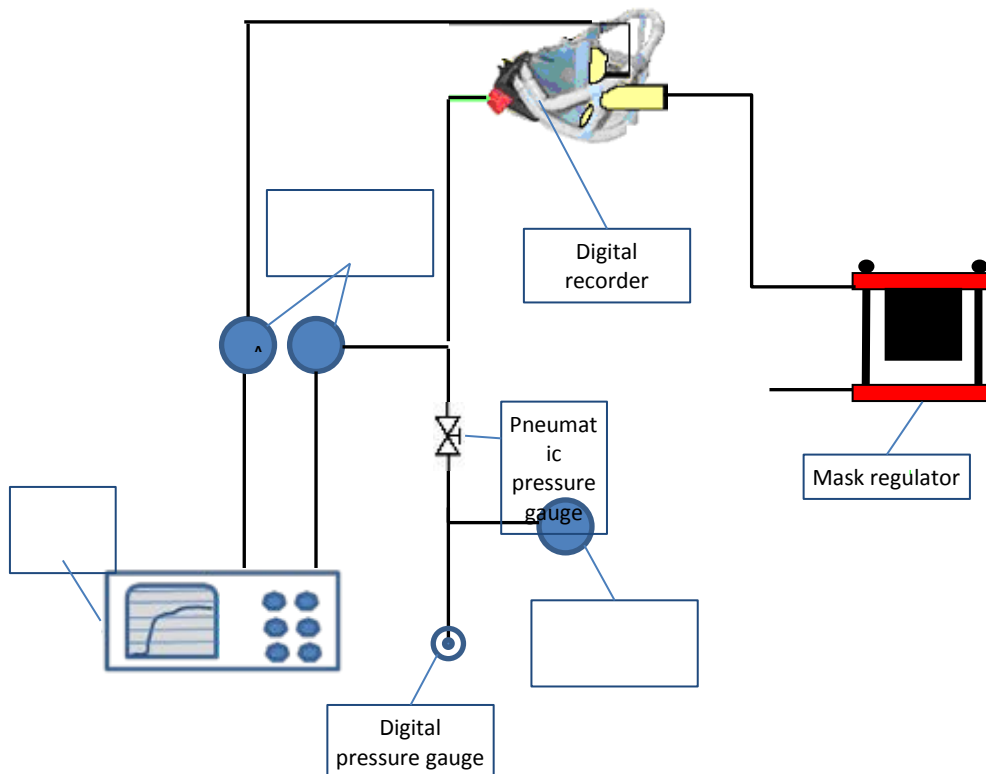

Figure 63 : Scheme for MC10-25-104 comfort test set-up





Figure 64 : Photo of MC10-25-104 comfort test set-up

### MXP147-3 Stowage Box

The only function of the stowage box, during operation of the mask, is the actuation / de-actuation of the pressure switch. Below is the test procedure :

- i. Plug stowage mask and box on pressure supply set to 0 bar
- ii. Increase pressure up to 0.26 MPa (2.6 bar ; 33.5 psi) with D-E open ; E-F closed
- iii. Record actuation pressure
- iv. Decrease pressure down to 0.0 MPa (0 bar ; 0 psi) with D-E closed ; E-F open
- v. Record deactuation pressure

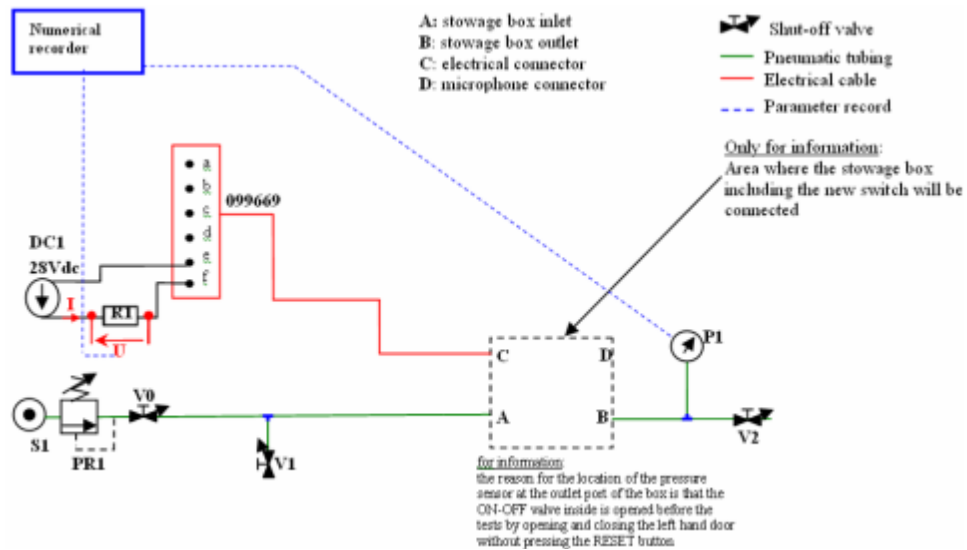

Figure 65: Scheme for MXP147-3 pressure switch actuation test set-up



Figure 66 : Photo of MXP147-3 pressure switch actuation test set-up

Results :

Harness inflation :

Mask S/N 150749 :

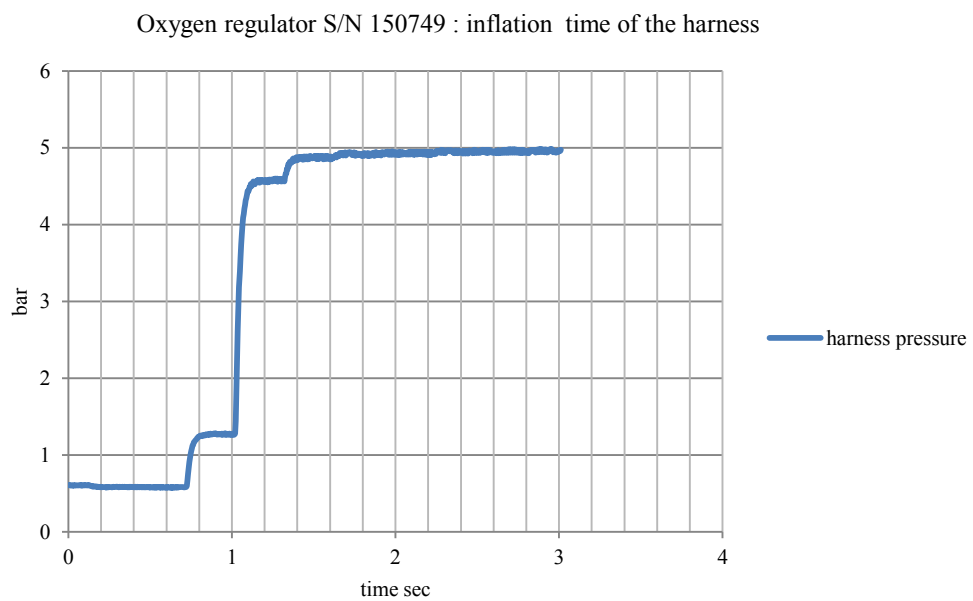

Figure 67 inflation test mask 150749

Mask S/N 150750 :

Oxygen régulator S/N 150750 : inflation time of the harness

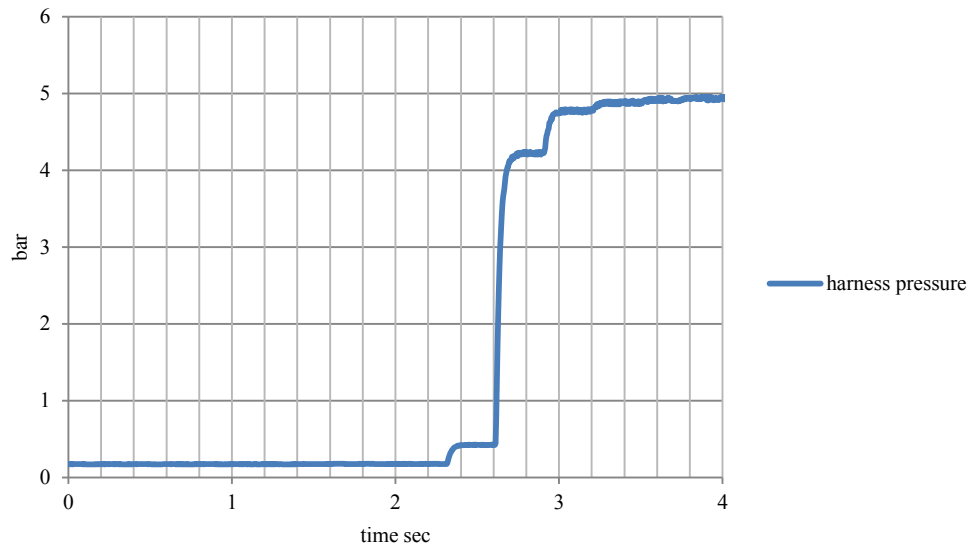

Figure 68 Inflation test mask 150750

Inflation test results :

Inflation time is below 1 sec for the two regulators. There is no sign of severe pollution inside the regulator.

Breathing sequences : 15 x 1 liter

Recording

Oxygen régulator S/N 150749 : respiratory cycle 15 x 1 liter 100 % position

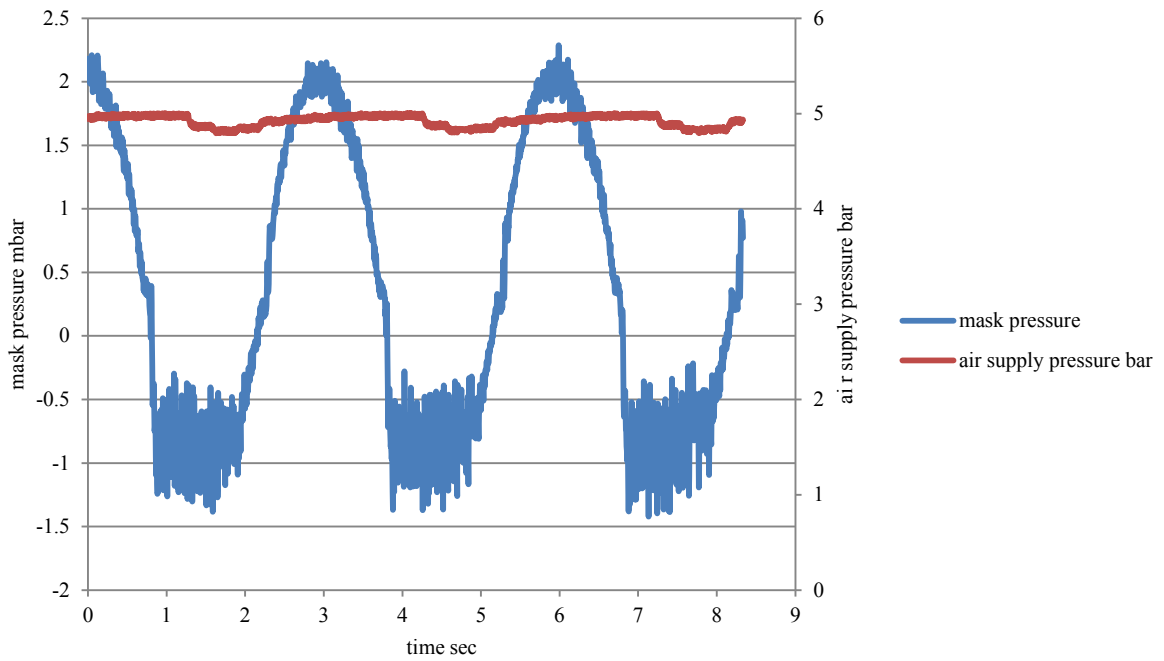

Figure 69 : respiratory cycle 100% position

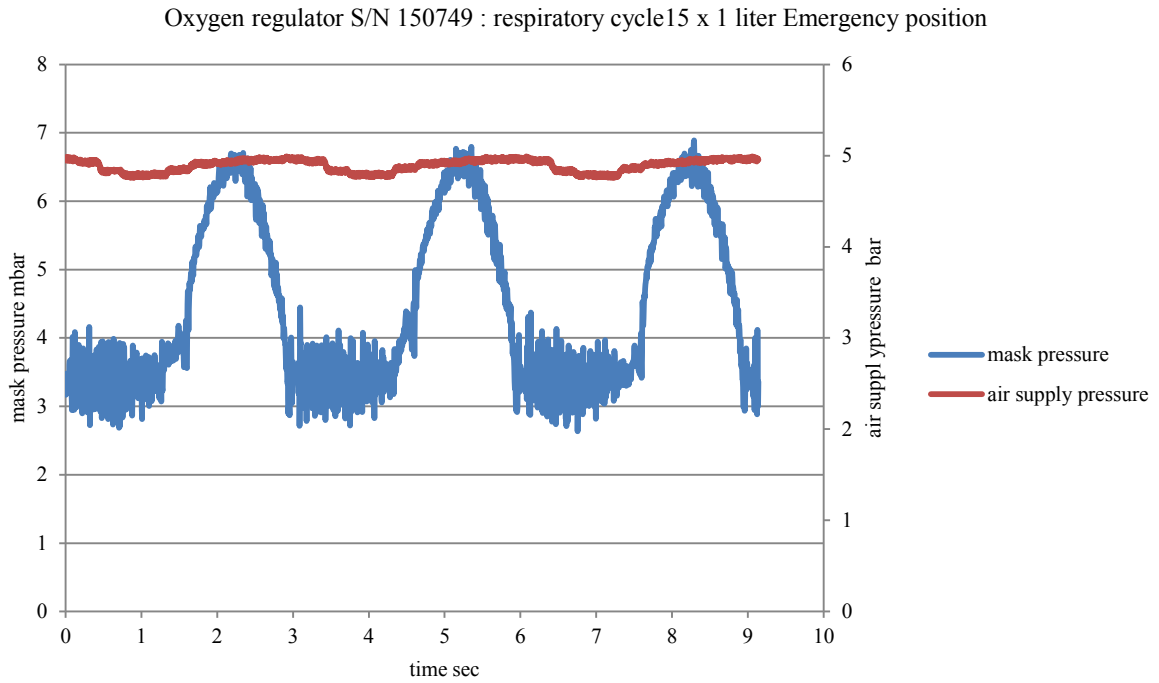

Figure 70 : respiratory cycle emergency position

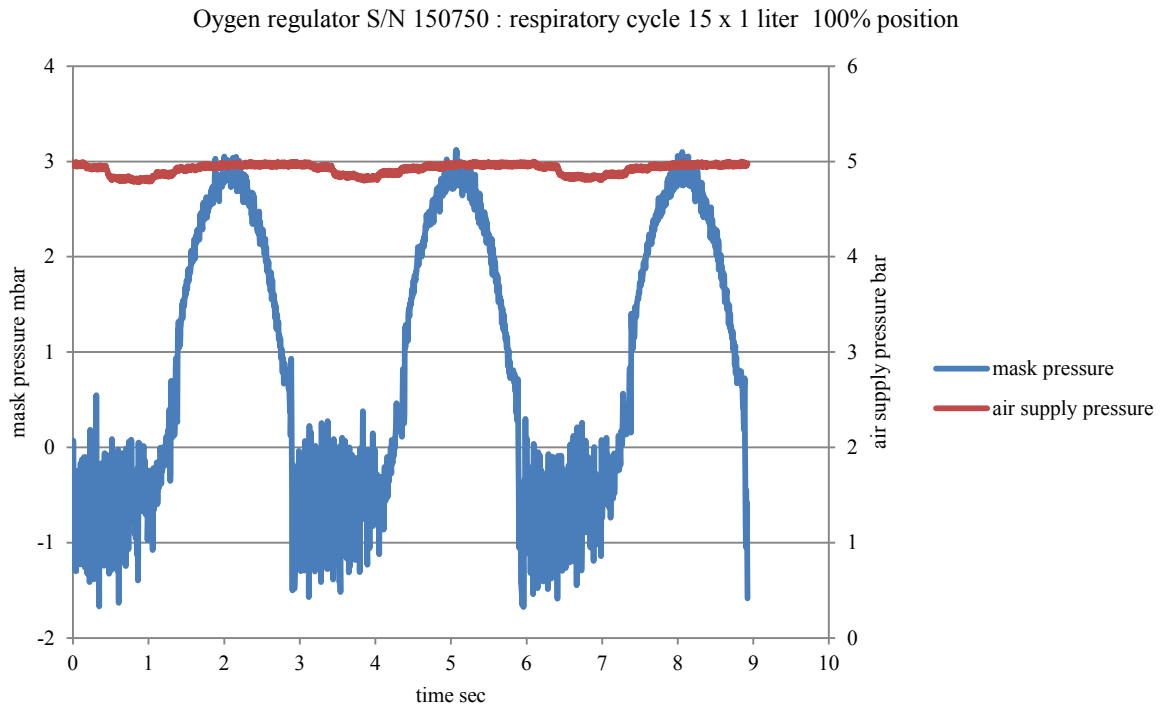

Figure 71 respiratory cycle 100% position

Oxygen regulator S/N 150750 : respiratory cycle 15 x 1 liter Emergency position

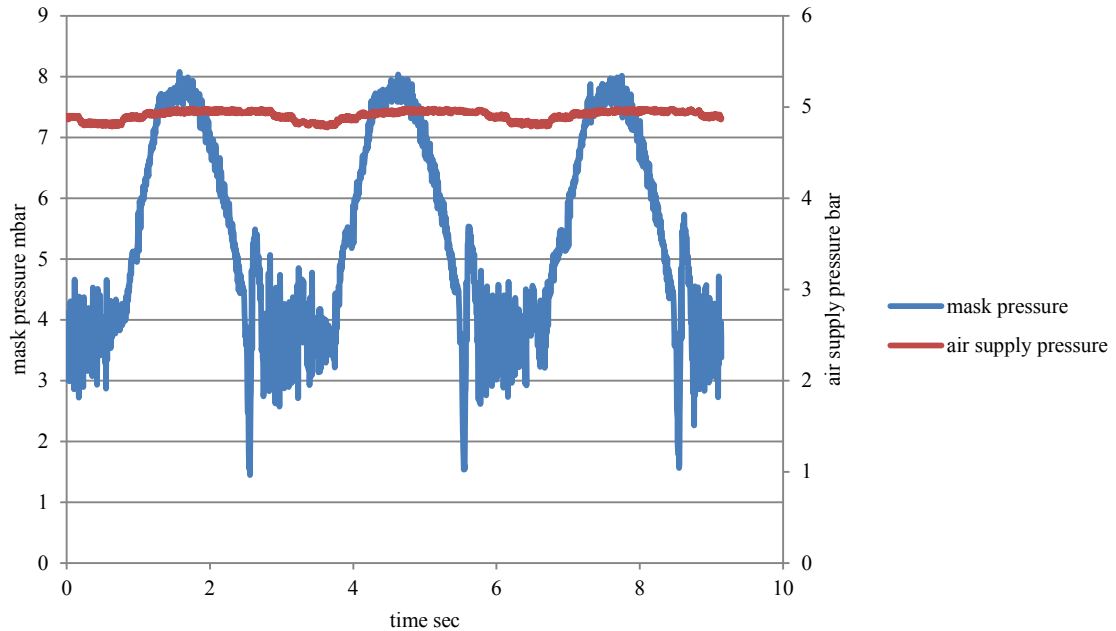

Figure 72 : respiratory cycle emergency position

Respiratory cycle results:

There are no abnormalities on the graphs. Response time of the membrane is within the expected values. Additional tests were performed on test bench 098869 using on our production line.



Figure 73 : Photo of 098869 test bench

Values were not recorded, however closing time was between specified values of 0.95 s and 1.30 s for both oxygen regulators.

Pressure switch activation and de-activation :

## Recording

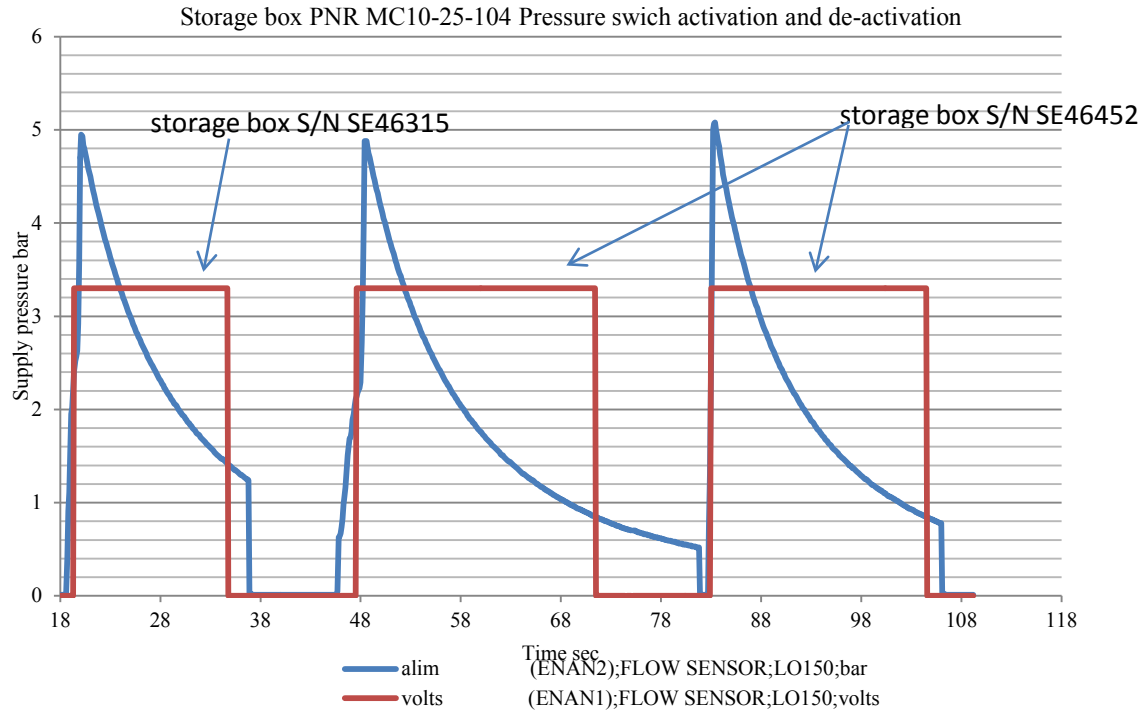

Figure 74 : pressure switch activation and de activation

### Pressure switch activation and de activation results

Storage box	Pressure switch actuation	Pressure switch de-actuation
S/N SE46315	2 bar	1.4 bar
S/N SE46452	2 bar	0.85 bar

For both storage boxes, actuation pressure was below 2.6 bar, and de-actuation pressure was above 0 bar, as specified.

### CONCLUSION:

- i Results of the tests performed on oxygen regulators and storage boxes show no sign of malfunction.
- ii There is no evidence of pollution on our products after furnace tests.
- iii Tests reported in this document show that functions of MC10-25-104 mask regulators and MXP147-3 storage boxes were not affected by previous furnace tests on upstream hose.

D: FAA/NTSB REPORT FIRE LOAD CONTRIBUTION OF LITHIUM AND LITHIUM ION BATTERIES REPORT

**NATIONAL TRANSPORTATION SAFETY BOARD**

Office of Research and Engineering  
Materials Laboratory Division  
Washington, D.C. 20594



3/21/2012

MATERIALS LABORATORY STUDY REPORT Report No. 12-019

Accident Information

Place : Dubai, UAE  
Date : 9/3/2010  
Vehicle : Boeing 747-400F  
NTSB No. : DCA10RA092

TOPICS ADDRESSED

- Fire load contribution of lithium and lithium-ion batteries
- Burning characteristics of aircraft cargo container fires

DETAILS OF THE STUDY

Fire load contribution of lithium and lithium-ion batteries

Lithium<sup>102</sup> and lithium-ion<sup>103</sup> batteries have been in the spotlight for the past few years due to their possible involvement in aircraft cargo fires. Recently there have been two in flight fire accidents in which the involvement of lithium and lithium-ion batteries has come into question. One of these accidents was UPS flight 1307, a McDonnell Douglas DC-8-71F which conducted an emergency landing on February 7, 2006, at Philadelphia International Airport. Although a successful emergency landing was made, the aircraft was a total loss by the time the fire was extinguished. Numerous fire-damaged batteries and battery-containing devices were found amongst the cargo, although no specific source was identified as the cause of the fire. The other accident with a possible lithium or lithium-ion battery involvement is UPS flight 6, a Boeing 747-400F which crash-landed on a military base in Dubai, United Arab Emirates (UAE) on September 4, 2010. This accident is currently under investigation by the General Civil Aviation Authority (GCAA) of the UAE. The preliminary report sites numerous shipments of batteries in the cargo manifest. One of the reasons batteries have been suspected in cargo fire incidents is due to the large number of instances where lithium and lithium-ion batteries in personal devices have been found to have led to a smoke, fire, or extreme heat event (FAA Office of Security and Hazardous Materials, 2011). In some situations, the causes of the batteries' failures were

<sup>102</sup> Lithium batteries are non-rechargeable (primary) cells containing lithium metal and a combustible electrolyte.

<sup>103</sup> Lithium-ion batteries are rechargeable (secondary) cells which have a combustible electrolyte but do not contain lithium metal.

clear, such as shorting, mechanical damage and improper charging. In other situations, the cause was unknown.

To date, the hazard posed by lithium and lithium-ion batteries has not been fully understood and quantified by the fire protection community. A material or assembly of materials, as is the case in batteries, can have many characteristics that play a role in its ability to pose a fire hazard. Such characteristics can include, but are not limited to:

- High sensitivity to mechanical, thermal or electrical abuse
- Potential for thermal runaway
- The amount of energy released when burning
- Incendiary particles expelled during battery case rupture
- Pressure pulses associated with case rupture
- Toxic products of combustion
- Resistance to extinguishment

Some of these characteristics have been studied through previous experimentation, such as the behavior of both lithium and lithium-ion batteries when exposed to a small heat source (Webster, Flammability Assessment of Bulk-Packed, Nonrechargeable Lithium Primary Batteries in Transport Category Aircraft, June 2004). Additionally, there have been some experiments to evaluate the magnitude of the pressure pulse associated with energetic battery failures (Webster, Lithium-Ion and Lithium Metal Battery Update, October 27, 2010).

This portion of the study focused on quantifying the energy released per individual battery cell and then on quantifying the fire behavior of small quantities of batteries in different scenarios. The following table describes the test series in the battery portion of this study.

<b>Test Series Name</b>	<b>Types of Batteries used</b>	<b>Test Scenario Description</b>
<b>Batteries#1</b>	Lithium, lithium-ion, lithium-ion polymer	Individual battery cell fire tests using oxygen consumption calorimetry
<b>Batteries#2</b>	Lithium-ion 18650 type	Box of 100 batteries exposed to a propane burner simulating being a victim of an unrelated fire
<b>Batteries#3</b>	Lithium-ion 18650 type	Box of 100 batteries initiating a fire amongst ordinary combustibles

The focus of the tests in the Batteries#1 test series was to quantify the amount of energy released per single battery by conducting a series of small scale tests using lithium, lithium-ion and lithium-ion polymer batteries. Knowing this information can allow for the estimation of the amount of energy a certain number of batteries; for example, a package of batteries placed in cargo can contribute to a fire. Although it is expected that the total



energy is a summation of the energy potential of each battery cell in the shipment and therefore can be predicted, the actual rate at which this energy is released greatly depends on the configuration of the batteries and the thermal exposure they receive and cannot be determined solely based on the number of batteries present.

The energy contribution of lithium and lithium-ion batteries involved in a fire was evaluated by means of oxygen consumption calorimetry.<sup>104</sup> The first series of tests was conducted using single battery cells (lithium, lithium-ion, and lithium-ion polymer<sup>105</sup>) at a time and they were conducted at the Fire Research Branch of the Federal Aviation Administration’s Technical Center (FAATC) in Atlantic City, NJ. The second series of tests was conducted using single boxes of batteries (containing 100 lithium-ion batteries each) and were conducted at the Fire Research Laboratory of the Bureau of Alcohol Tobacco Firearms and Explosives (BATFE). The tests carried out at the FAATC were performed using an oxygen consumption calorimeter as described in the standard test method ATSM E-1354.<sup>106</sup> The test involves subjecting a test specimen, in this case a battery cell, to a uniform external heat flux and then measuring the amount of oxygen consumed during the combustion of the test specimen. The mass of oxygen consumed is then related to the energy released during the combustion of the battery cell. The tests conducted at the BATFE were performed under exhaust hoods instrumented for oxygen consumption calorimetry.

The types of batteries used in these tests were of the lithium, lithium-ion, and lithium-ion polymer variety. These batteries are shown in table 1.

Table 12: Batteries tested

<b>Manufacturer</b>	<b>Type</b>	<b>Model</b>	<b>Capacity</b>
<b>LG Chem Ltd Seoul, South Korea</b>	Lithium-ion	18650	2600 mAh
<b>Titanium Innovations inc Essex, CT</b>	Lithium	CR2	unavailable
<b>SureFire LLC Fountain Valley, CA</b>	Lithium	SF123A	unavailable
<b>Powerizer</b>	Lithium-ion	PL-553562-10C	1050 mAh

<sup>104</sup> Oxygen consumption calorimetry is a method of measuring a material’s energy release rate during combustion by relating the amount of oxygen consumed to the energy released.

<sup>105</sup> This type of battery has technologically evolved from lithium-ion batteries. The primary difference is that the lithium-salt electrolyte is not held in an organic solvent but in a solid polymer composite such as polyethylene oxide or polyacrylonitrile.

<sup>106</sup> ASTM E-1354 Standard test method for heat and visible smoke release rates for materials and products using an oxygen consumption calorimeter.

	polymer		
<b>Powerizer</b>	Lithium-ion polymer	PL-603495-10C	1900 mAh

### 1.a Battery tests at the FAATC (test series Battery#1)

The batteries tested at the FAATC using the ASTM E-1354 apparatus, also referred to as the “cone calorimeter” (due to the conically shaped heating element), were tested in duplicate with the heater set at  $10 \frac{kW}{m^2}$ ,  $30 \frac{kW}{m^2}$ ,  $50 \frac{kW}{m^2}$  and  $75 \frac{kW}{m^2}$ . At  $10 \frac{kW}{m^2}$  the battery behavior was erratic with instances of non-ignition of the expelled electrolyte or lack of violent battery venting<sup>107</sup> altogether. In general, the behavior of all the types of batteries tested, with the exception of the lithium-ion polymer batteries, was to vent twice, and therefore an initial and final venting time was recorded during each test. The following tables (2 - 6) show the results from the tests.

Table 13: LG lithium-ion 18650 batteries

Battery Model	Heat Flux <sup>108</sup> ( $\frac{kW}{m^2}$ )	Initial Vent <sup>109</sup> (sec)	Final Vent <sup>110</sup> (sec)	Peak HRR <sup>111</sup> (kW)	Total HR <sup>112</sup> (kJ)	Mass loss <sup>113</sup> (g)	Heat of Combustion <sup>114</sup> ( $\frac{kJ}{g}$ )
18650	30	165	242	13.7	84	10.3	8.2
18650	30	166	242	9.8	76	12.6	6.0
18650	50	109	159	10.2	100.2	10.1	9.9
18650	50	96	137	16.2	92.8	9.6	9.7
18650	75	56	75	12.3	81.6	9.1	9.0
18650	75	50	71	16.2	92.5	9.1	10.2

Table 14: Titanium Innovations lithium CR2 batteries

Battery Model	Heat Flux ( $\frac{kW}{m^2}$ )	Initial Vent (sec)	Final Vent (sec)	Peak HRR (kW)	Total HR (kJ)	Mass loss (g)	Heat of Combustion ( $\frac{kJ}{g}$ )
CR2	30	115	148	2.8	27	3.3	8.2
CR2	30	118	161	3.1	32	3.2	10.0

<sup>107</sup> Battery venting is the expulsion of electrolyte from the battery due to internal overpressure of the battery usually caused from the battery experiencing a thermal runaway.

<sup>108</sup> Heat flux is the magnitude of the thermal exposure that the test specimen is subjected to.

<sup>109</sup> Time after exposure to heat source that the initial vent occurred

<sup>110</sup> Time after exposure to heat source that the final vent occurred

<sup>111</sup> Peak HRR is the instantaneous peak heat release rate of the combusting sample. Also referred to as energy release rate.

<sup>112</sup> Total HR is the time integrated heat release rate of the test and represents the total amount of energy released during combustion. Also referred to as total energy release.

<sup>113</sup> Total mass of sample consumed during the test

<sup>114</sup> The heat of combustion is the total heat release divided by the mass loss and represents the energy liberated per unit mass of combustible consumed.

CR2	50	77	85	3.9	20.3	3.4	6.0
CR2	50	90	118	3.7	33.1	3.5	9.5
CR2	75	54	65	6.5	33.5	2.3	14.6
CR2	75	54	70	4.2	31.4	3.7	8.5

Table 15: Sure Fire lithium SF123A batteries

Battery Model	Heat Flux ( $\frac{kW}{m^2}$ )	Initial Vent (sec)	Final Vent (sec)	Peak HRR (kW)	Total HR (kJ)	Mass loss (g)	Heat of Combustion ( $\frac{kJ}{g}$ )
SF123A	30	104	149	4.2	42	4.7	8.9
SF123A	30	113	149	3.6	55	8.4	6.5
SF123A	50	74	94	3.9	52.2	4.4	11.9
SF123A	50	69	89	4.7	73.5	4.4	16.7
SF123A	75	48	68	5.9	64	3.8	16.8
SF123A	75	52	67	3.5	44.6	4.3	10.4

Table 16: Powerizer lithium-ion polymer PL553562-10C batteries

Battery Model	Heat Flux ( $\frac{kW}{m^2}$ )	Initial Vent (sec)	Final Vent (sec)	Peak HRR (kW)	Total HR (kJ)	Mass loss (g)	Heat of Combustion ( $\frac{kJ}{g}$ )
PL-553562-10C	30	112	N/A	9.2	57	3.3	17.3
PL-553562-10C	30	130	N/A	8.9	47	2.9	16.2
PL-553562-10C	50	38	51	6	77	5.1	15.1
PL-553562-10C	50	48	63	5.7	75	5.6	13.4
PL-553562-10C	75	14	44	7.1	109	6.1	17.9
PL-553562-10C	75	22	31	5.8	97	7.2	13.5

Table 17: Powerizer lithium-ion polymer PL603495-10C batteries

Battery Model	Heat Flux ( $\frac{kW}{m^2}$ )	Initial Vent (sec)	Final Vent (sec)	Peak HRR (kW)	Total HR (kJ)	Mass loss (g)	Heat of Combustion ( $\frac{kJ}{g}$ )
PL-603495-10C	30	64	84	7.8	156	10.2	15.3
PL-603495-10C	30	68	88	7	145	9.8	14.8
PL-603495-10C	50	35	52	8	162	11.1	14.6
PL-603495-10C	50	35	58	5.8	147	11.1	13.2
PL-603495-10C	75	19	35	8.9	165	12.1	13.6
PL-603495-10C	75	22	39	7.4	170	12	14.2

Based on the data in tables 2 – 6, there does not appear to be a strong and consistent trend of increasing peak energy release rate with increasing heat flux applied to the sample. The mass loss, total heat release, and therefore heat of combustion remain fairly constant regardless of the heat flux applied to the sample. The average values of the previously tabulated results, across tests of all heat flux levels, are shown in the following table.

Table 18: Average values across all heat flux levels of measured test results

Battery Type	Average Peak HRR (kW)	Average Total HR (kJ)	Average Mass loss (g)	Average Heat of Combustion ( $\frac{kJ}{g}$ )
<b>18650</b>	13	88	10.1	8.7
<b>CR2</b>	4	29.5	3.2	9.2
<b>SF123A</b>	4.3	55	5.8	9.5
<b>PL-553562-10C</b>	7.1	77	5.8	13.3
<b>PL-603495-10C</b>	7.5	157.5	11	14.3

Example plots of the time resolved heat release rate of each type of battery tested follow. The remainder of the test results from the single cell battery tests can be found in appendix A.

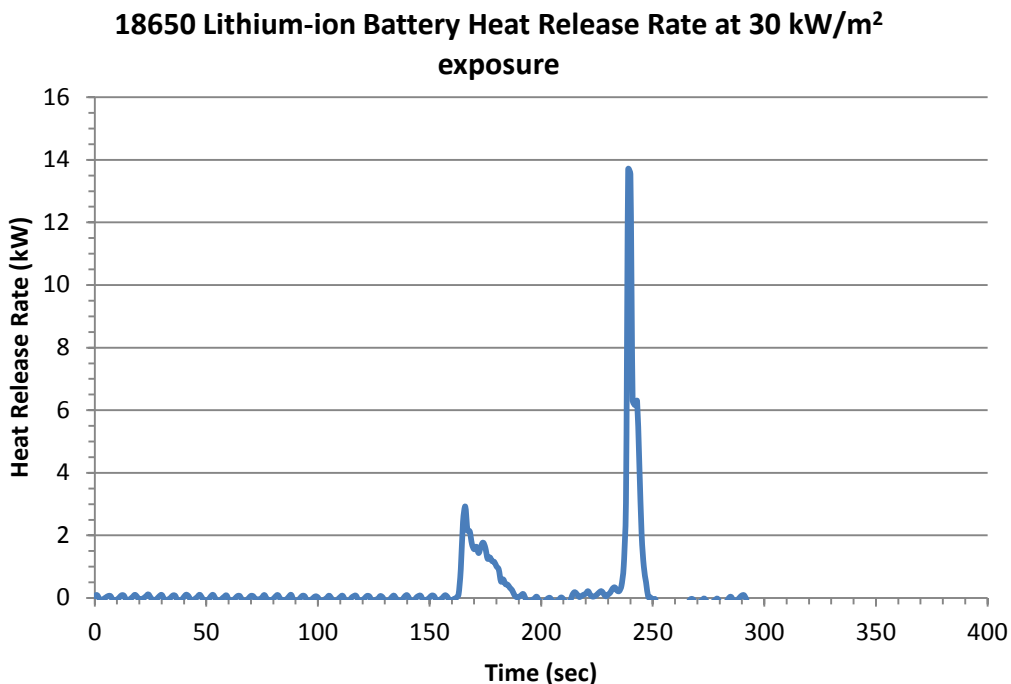

Figure 75: Heat release rate from a single 18650 battery exposed to a heat flux of 30 kW/m<sup>2</sup>

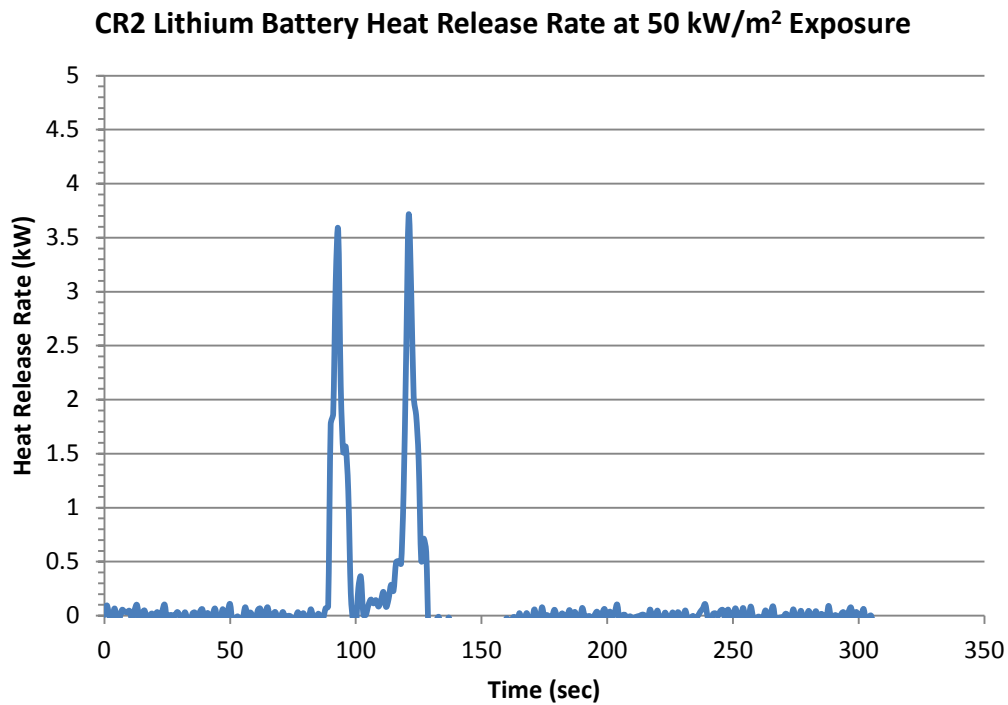

Figure 76: Heat release rate from a single CR2 battery exposed to a heat flux of 50 kW/m<sup>2</sup>

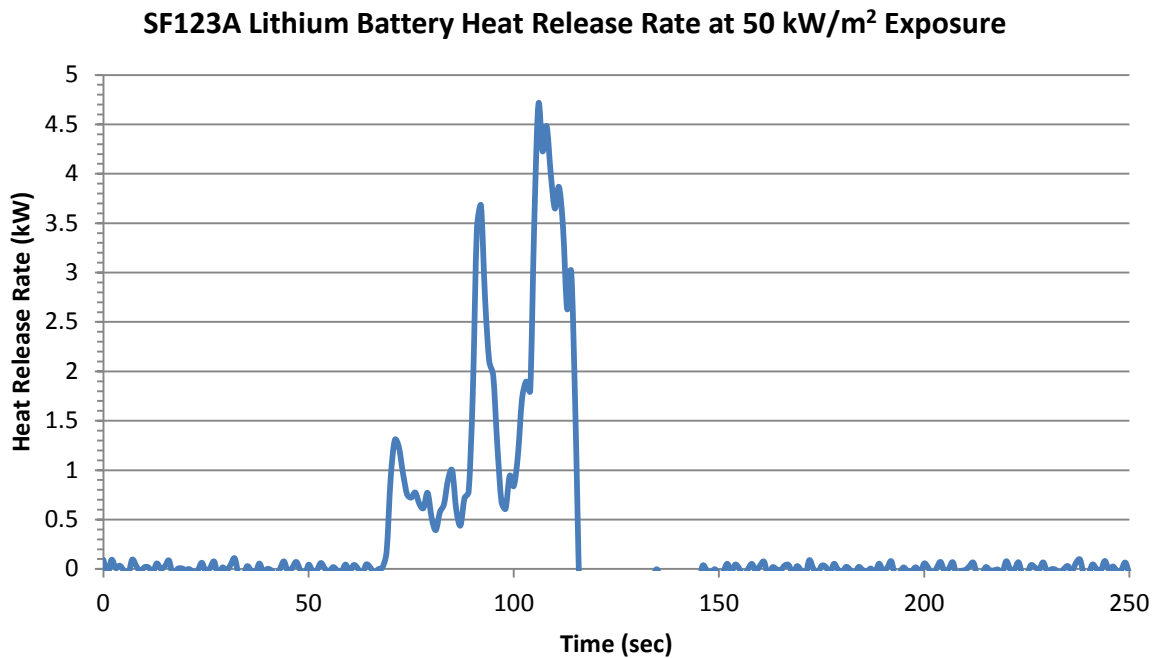

Figure 77: Heat release rate from a single SF123A battery exposed to a heat flux of 50 kW/m<sup>2</sup>

**PL-553562-10C Lithium-ion Battery Heat Release Rate at 75 kW/m<sup>2</sup>  
Exposure**

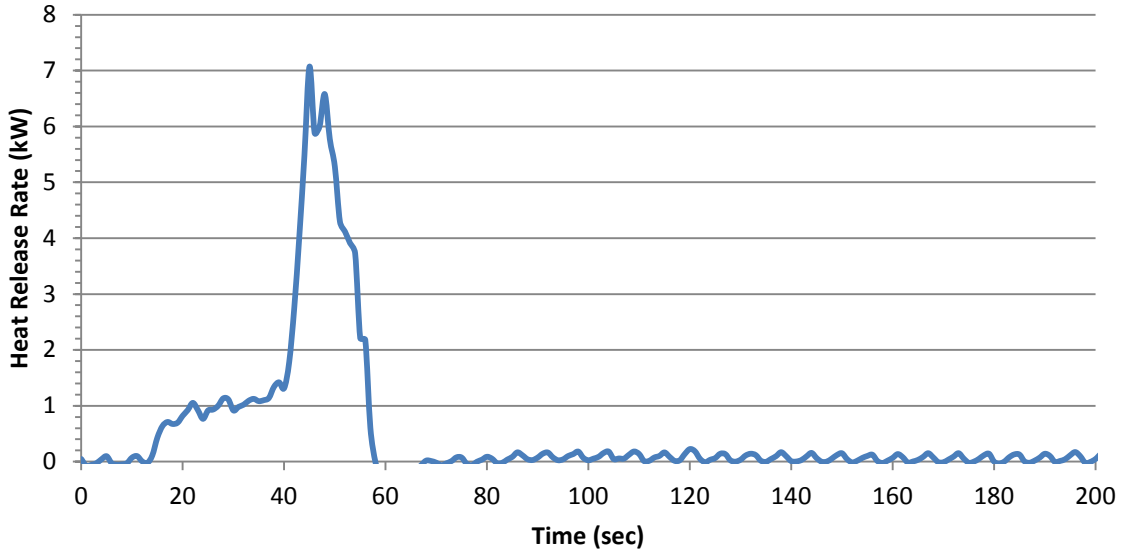

Figure 78: Heat release rate from a single PL-553562-10C battery exposed to a heat flux of 75 kW/m<sup>2</sup>

**PL-603495-10C Lithium-ion Battery Heat Release Rate at 75 kW/m<sup>2</sup>  
Exposure**

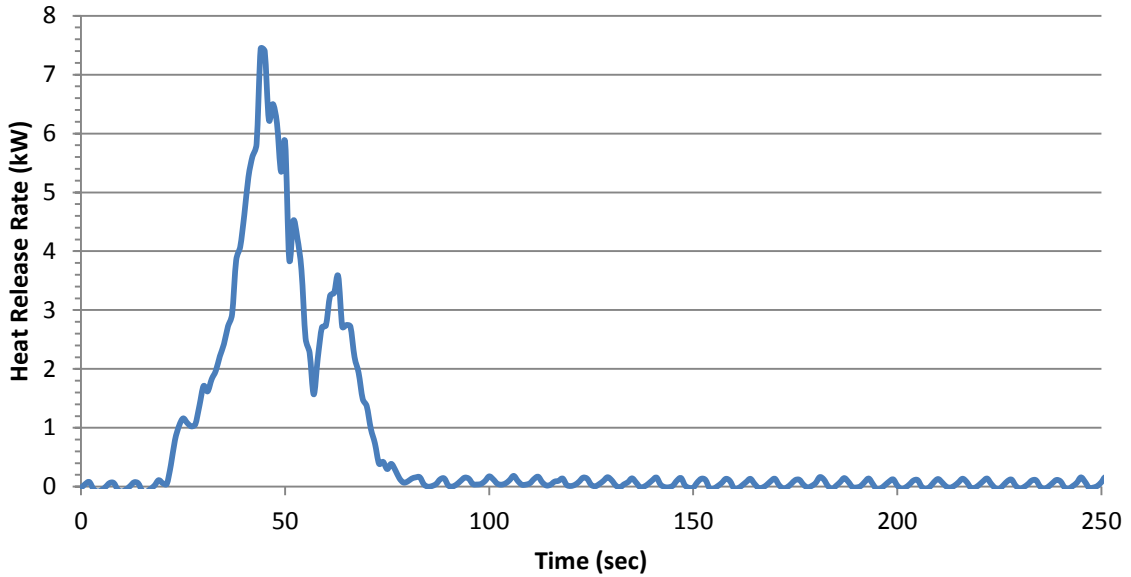

Figure 79: Heat release rate from a single PL-603495-10C battery exposed to a heat flux of 75 kW/m<sup>2</sup>

In the case of lithium-ion (and lithium-ion polymer) batteries, the combustible substance is limited to the electrolyte within each cell since there is no lithium metal present. The heat of combustion calculated from these experiments represents the heat of combustion of the electrolyte which was found to be  $8.7 \frac{kJ}{g}$  for the 18650 type batteries and an average of  $13.8 \frac{kJ}{g}$  for the two types of lithium-ion polymer batteries tested. In the case of the lithium (primary) batteries tested, the combustible substances are both the electrolyte and lithium metal. The combined heat of combustion of both substances was found to be on average, for both types of lithium batteries,  $9.3 \frac{kJ}{g}$ . These heats of combustion are lower than those of ordinary cellulosic materials such as newspaper  $19.7 \frac{kJ}{g}$ <sup>115</sup> and significantly lower than those of typical combustible & flammable fluids which vary in the range of  $35 \frac{kJ}{g}$  to  $45 \frac{kJ}{g}$ <sup>116</sup>. If the heat of combustion were to be calculated based on the overall mass of the battery rather than the mass loss, then the heats of combustion for the batteries tested are even lower as shown in the following table.

Table 19: Heat of combustion based on total mass

Battery Type	Average Total HR (kJ)	Average total mass (g)	Heat of Combustion based on total mass ( $\frac{kJ}{g}$ )
<b>18650</b>	88	43.5	2
<b>CR2</b>	29.5	10.5	2.8
<b>SF123A</b>	55	16.4	3.3
<b>PL-553562-10C</b>	77	23.3	3.3
<b>PL-603495-10C</b>	157.5	41.3	3.8

Although the sensitivity to thermal abuse was not the focus of this study, plotting the results of the time to the first vent versus the incident heat flux (figure 6) of each test and fitting the data to exponential curves produces a graph suggesting a critical heat flux (CHF)<sup>117</sup> for lithium-ion battery failure of approximately  $5 \frac{kW}{m^2}$  for the types of batteries tested in this study. This number is based on limited data and the tests were terminated after 15 minutes without battery failure. With more tests at heat flux levels around the established CHF and longer test durations, this number could be further refined.

<sup>115</sup> SFPE handbook 2<sup>nd</sup> edition, Appendix C, Table C-4.

<sup>116</sup> SFPE handbook 2<sup>nd</sup> edition, Appendix C, Table C-4.

<sup>117</sup> Critical heat flux (CHF) is the limiting incident heat flux on a material below which ignition will not occur.

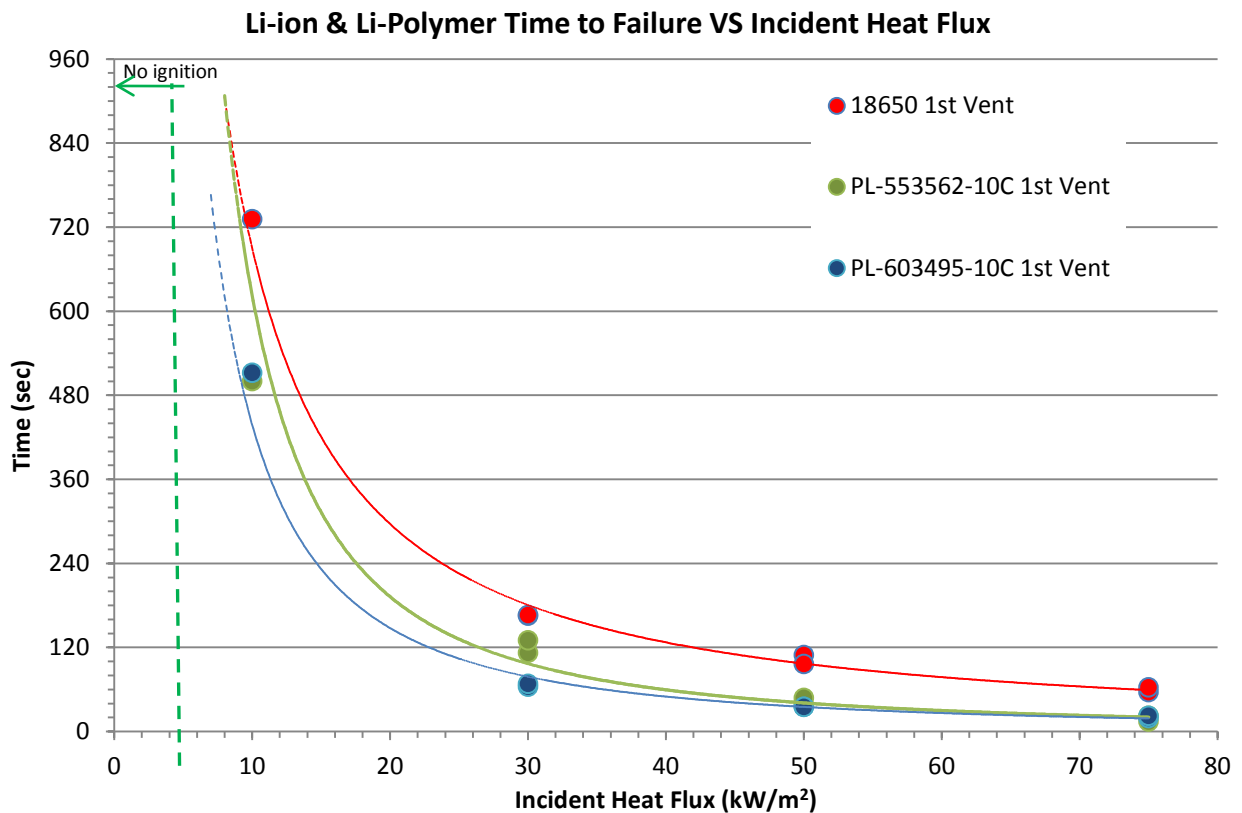

Figure 80: Battery failure time versus incident heat flux

### 1.b Battery testing at BATFE (test series Battery#2)

The tests in the series named Battery#2 and Battery#3 were conducted at the BATFE and burned under an exhaust hood instrumented for oxygen consumption calorimetry. Four tests were conducted, each using one box of 100 LG lithium-ion 18650 batteries. Series Battery#2 consisted of two tests that were carried out using a propane burner beneath the batteries to initiate the fire, and series Battery#3 consisted of two tests using a cartridge heater within the box of batteries to initiate the fire. The first case represents of a box of batteries exposed to an unrelated heat source and the second case represents a box of batteries self igniting.

In the case of exposing the box of batteries to a propane burner flame, the test setup is shown in figure 7. The box of batteries was placed on a stand constructed of angle iron which straddled the propane burner. The propane burner was controlled through a computer and a mass flow controller so that a steady output of 30 kW could be maintained throughout the test. On all four sides of the box of batteries, 22 inches away, were water-cooled Gardon type heat flux gauges. Adjacent to the box of batteries and extending vertically was a thermocouple “tree” to record temperatures in the fire plume above the batteries.



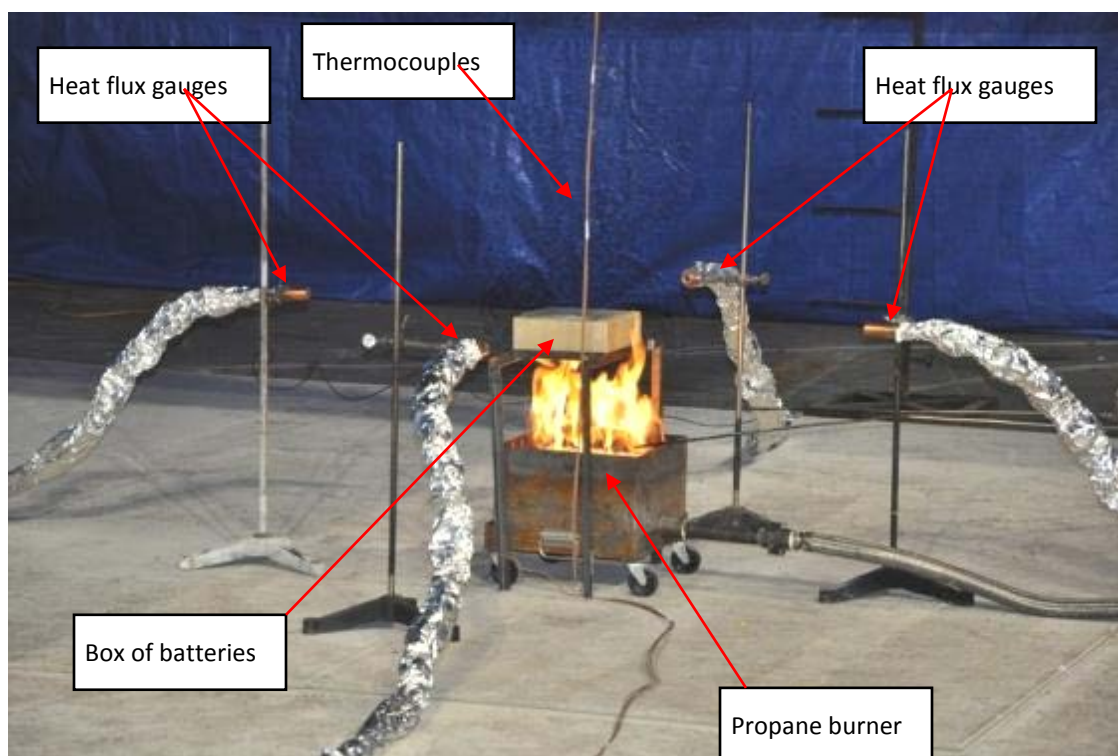

Figure 81: Test setup for batteries exposed to an unrelated fire

A graph showing the time resolved energy release rate of an example test is shown in figure 8. A red horizontal dotted line on the graph indicates the level of the energy output from the propane burner. At the beginning of the test, the measured energy output is briefly 30 kW and grows to 40 kW, where it remains for a few minutes before the batteries begin to get involved. This 10 kW excursion above the burner output prior to the batteries getting involved is likely the energy release due to the burning of cardboard box containing the batteries. The timeframe where the batteries are venting and burning lies between 340 seconds and 660 seconds, as indicated by the dotted vertical lines on the graph. After the batteries are all consumed, the energy release rate goes back to approximately 30 kW. During its peak contribution to the fire, the box of batteries increased the energy release rate by 90 kW. The energy associated with the combustion of the batteries is the area under the energy release rate graph in the interval between 340 seconds and 660 seconds, minus the energy from the propane burner during the same time interval. That results in 11237 kJ for the box of 100 18650 type lithium-ion batteries or 112.4 kJ per battery. From the previous tests at the FAATC, the measured energy for the same type of battery was measured slightly lower at 88 kJ per battery. The discrepancy is likely due to differences in instrument sensitivity between the small scale cone calorimeter and large scale 1 MW hood calorimeter used for the tests at BATFE as well as possible small variations of the propane burner output.

Box of 100 lithium-ion batteries suspended over 30kW burner

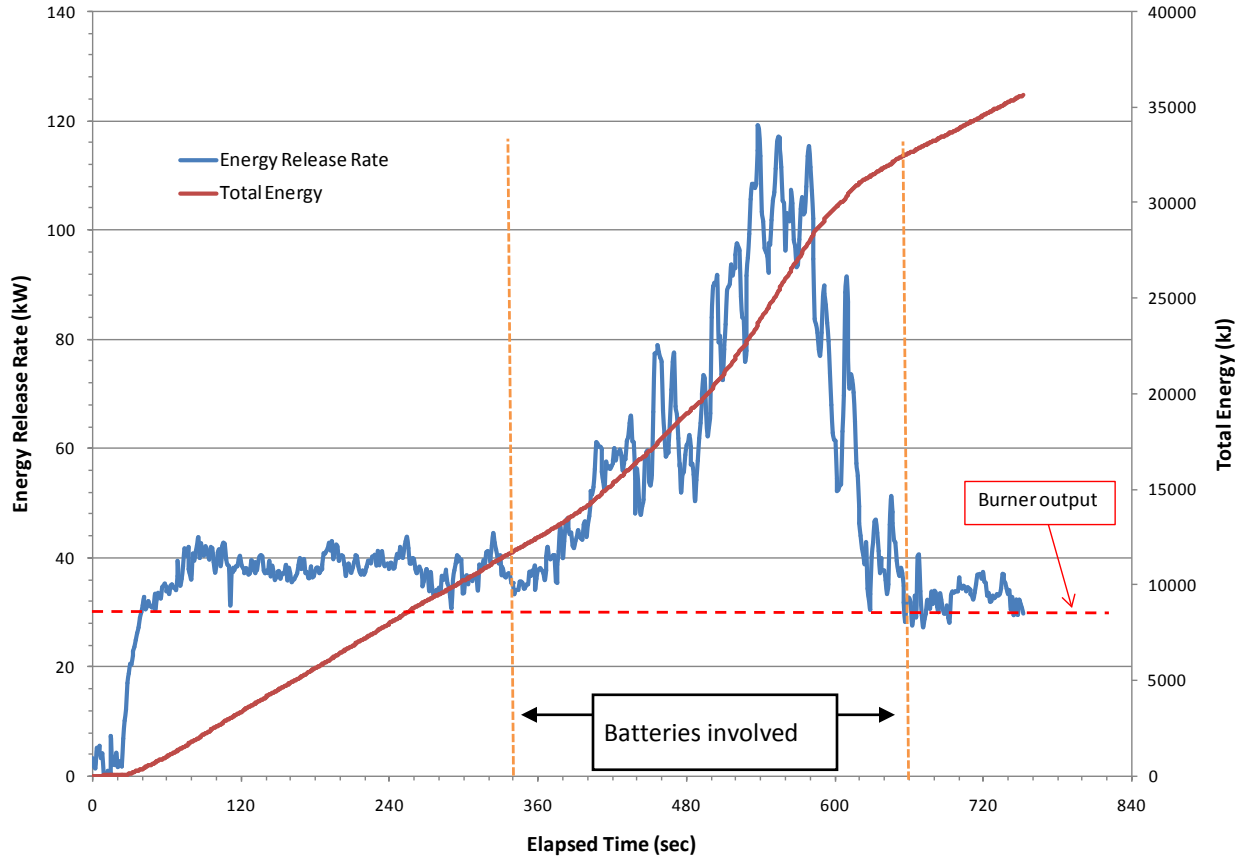

Figure 82: Graph of energy release rate and total energy

Box of 100 lithium-ion batteries suspended over 30kW burner

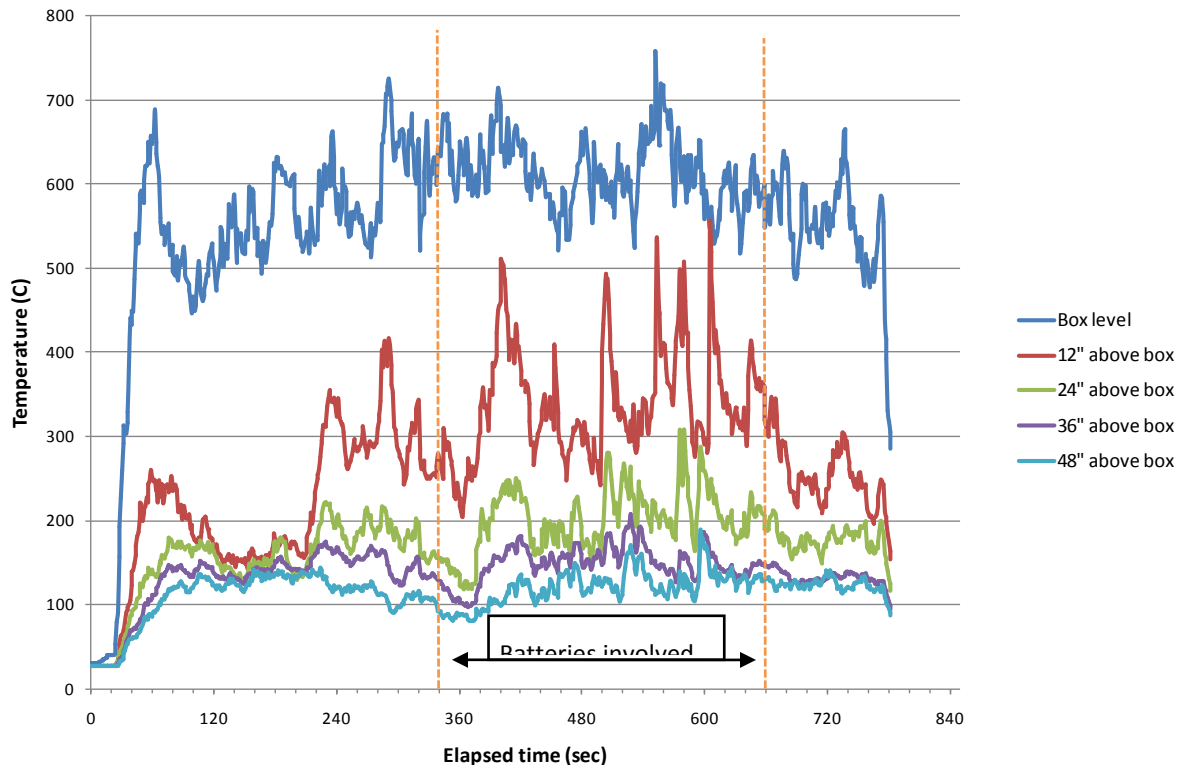

Figure 83: Graph of fire plume temperatures

The temperatures recorded during the test are shown in figure 9. The thermocouples were 24-gauge exposed bead type K thermocouples positioned in 12" increments vertically above the box of batteries with the first thermocouple being at the level of the box. The time interval during which the batteries were involved was between 340 seconds and 660 seconds as indicated by the vertical dotted lines on the graph. The overall plume temperatures were only affected at the 12-inch and 24-inch levels above the box of batteries. At those levels, the thermocouples appear to have been affected by the bursts of directional flames coming from the battery cells (figure 10) as evidenced by the temperature spikes recorded. The heat flux measurements are shown in figure 11. The peak heat flux recorded during the interval of battery involvement was just over  $5 \frac{kW}{m^2}$  which represents an increase of about  $3 \frac{kW}{m^2}$  above the heat flux due to the propane burner and burning cardboard alone.

Due to the violent nature of the battery case venting and combustion of the electrolyte, some of the batteries (or battery components) were liberated from the charred packaging and propelled several feet, landing onto the floor. Some of these projectiles continued to burn upon landing.



Figure 84: Box of lithium-ion batteries burning over propane burner exhibiting battery venting and electrolyte combustion

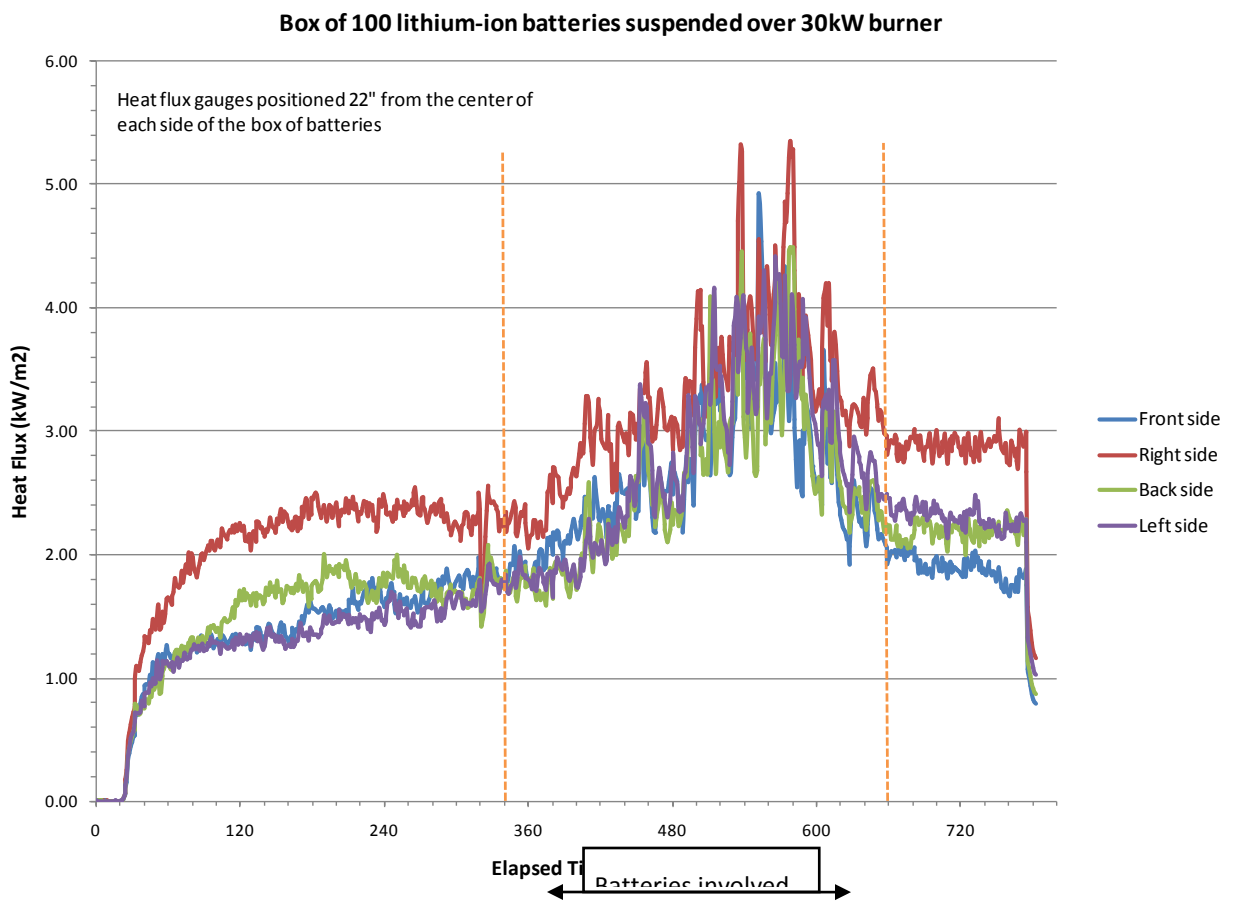

Figure 85: Graph of radiant heat flux measurements

To simulate the case of batteries being the cause of the fire and self-igniting, a 250-watt cartridge heater was used to simulate a battery going into thermal runaway. One cell in the corner of the box of 100 batteries was replaced by the cartridge heater (figure 12). In addition to the batteries, the fire load for each of the two tests included 18 cardboard boxes each containing 2.5 lb of shredded paper inside, arranged in a 3 x 3 array two levels high (figure 13). Each cardboard box was an 18" cube. The box of batteries was placed inside the cardboard box (and covered with 2.5lb of shredded paper) at the center of the top level of boxes in the array. The additional fire load was used to observe the battery thermal runaway spread to the rest of the combustibles and to determine if the presence of batteries in the fire load had any measureable effect. For reference, two control tests were conducted using 18 boxes and no batteries. Those fires were initiated by an electric match inside the cardboard box at the center of the top level of boxes in the array, just as in the tests that included the box of batteries.



Figure 86: Box of batteries with cartridge heater in place (circled in red)

In this test series (Battery#3), just as in the test with the box of batteries over the propane burner (Battery#2), radiant heat flux measurements and plume temperatures were recorded along with the oxygen consumption calorimetry. The test was run in duplicate. During the first iteration (test I), it appeared that the batteries vented without ignition of the expelled electrolyte until the very end, where it is unclear if the batteries or cartridge heater finally ignited the rest of the fire load. During the second iteration (test II), the vented electrolyte ignited early on in the test and actually caused a small explosion within the cardboard box in which the box of batteries was placed. The fire rapidly spread to the rest of the fire load and consumed it, leaving the batteries still venting and burning after all the boxes were consumed. The difference between the two tests was that for the first one, the box of batteries was placed in between the center boxes of the lower and upper layers of

boxes, and in the second test, the box of batteries was placed inside the center box of the upper layer.



Figure 87: Test setup for tests involving 18 cardboard boxes and one box of batteries

The graph of the energy release rates of both of the two tests involving cardboard boxes and batteries is shown in figure 14. On average, the tests involving the cardboard boxes and batteries had a peak energy release rate of 1.7 MW and a total energy of 298 MJ. The tests to which these results are to be compared to involved only cardboard boxes and no batteries. The results of these tests are shown in figure 15. On average, the tests involving just the cardboard boxes had a peak energy release rate of 1.6 MW and a total energy of 288 MJ. The tests involving the batteries did not exhibit any perceptible differences in the overall characteristics of the fires. Peak energy release rates were very similar and well within the variable nature of fire tests. The overall burning time of all the tests was also similar and was approximately 400 seconds. The average total energy of the tests which included the box of batteries was 10 MJ greater than the average of those tests that did not include the box of batteries. That difference is very close to the energy contribution of the box of batteries calculated from the propane burner tests. Temperatures measured in the fire plume of all these tests were also consistent regardless of the presence of batteries and peaked at  $1000\text{ }^{\circ}\text{C} \pm 100\text{ }^{\circ}\text{C}$ . The measured radiant heat flux also did not exhibit any significantly different results for the tests that included the batteries. The test reports from the BATFE containing all the test results for the battery tests with the propane burner and the battery tests with the array of cardboard boxes can be found in appendixes B and C respectively.

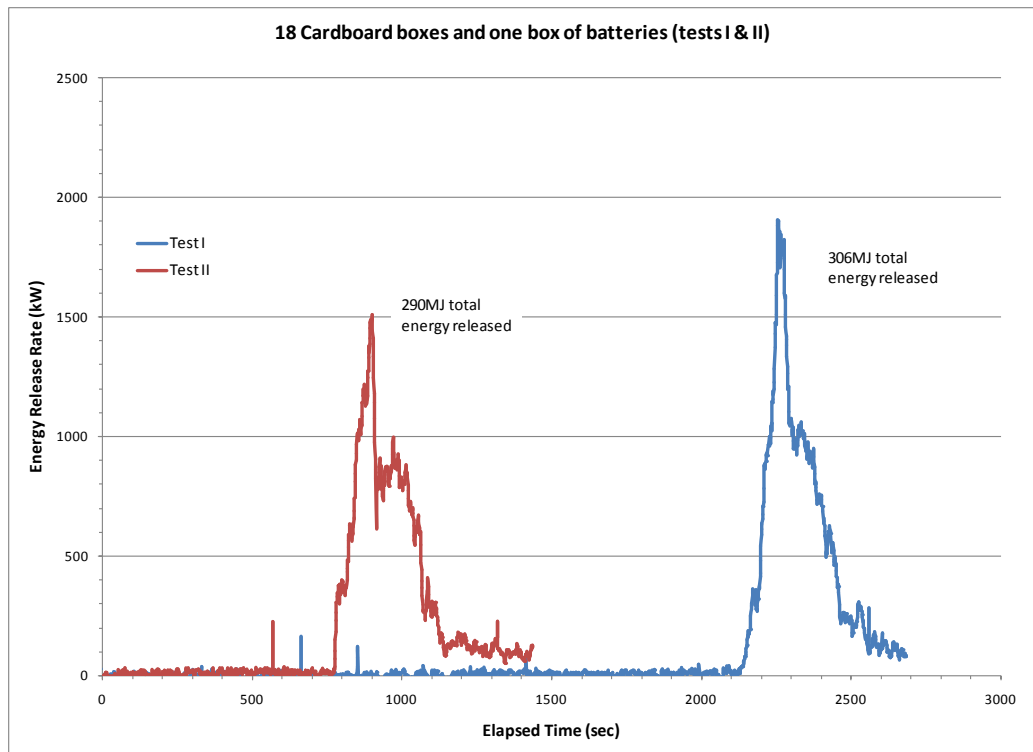

Figure 88: Energy release rate from tests involving cardboard boxes and batteries

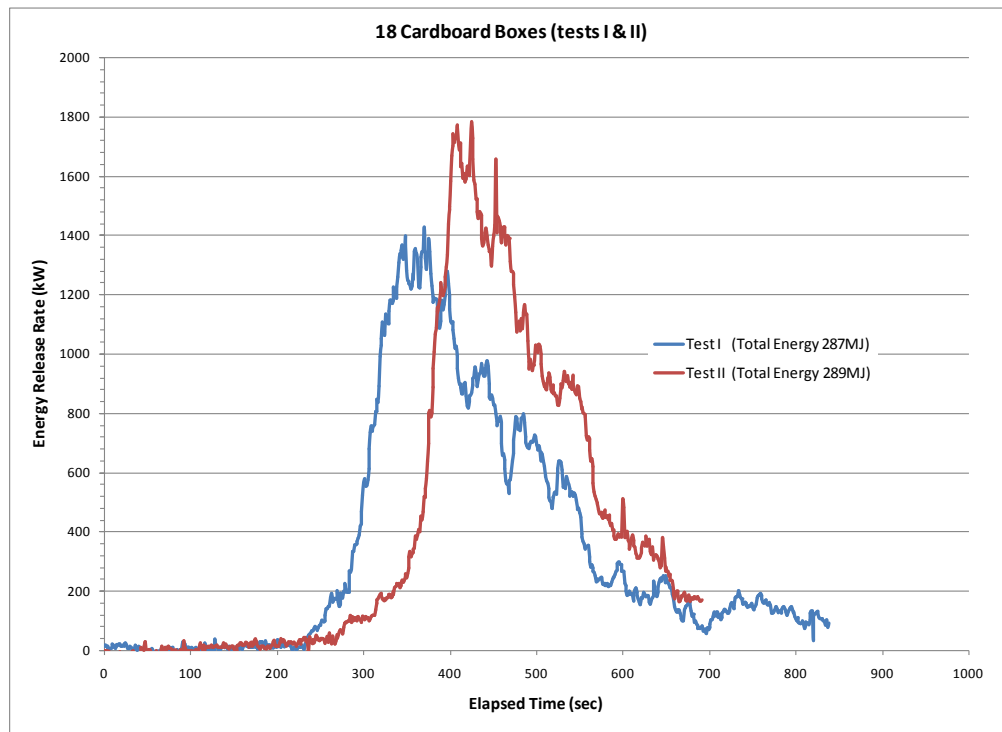

Figure 89: Energy release rate from tests involving cardboard boxes

Burning characteristics of aircraft cargo container fires

In the most recent freighter aircraft cargo fires, along with the speculation regarding the involvement of lithium and lithium-ion batteries, there have been questions among the aviation community relating to the overall characteristics of fires originating within cargo containers. These cargo fire accidents include the 2006 UPS flight 1307 in Philadelphia, PA, the 2010 UPS flight 006 in Dubai, UAE, and the 2011 Asiana flight 991 in South Korea. From the investigation of these recent accidents, there is evidence to suggest that there has been a short time frame from when a cargo fire is detected to when damage begins to occur to the aircraft's systems. This has been another reason why there is often speculation regarding the contribution of batteries to the severity of a cargo fire since there is a sense that aircraft are designed to withstand and contain an ordinary cargo fire.

In an effort to shed some light on the cargo fire problem and better understand why we are seeing catastrophic cargo fires, experiments were done to measure various characteristics of cargo container fires such as detectability, growth rate, and energy output. Once the characteristics of a cargo fire are known, then the appropriateness of the current fire protection strategies can be evaluated. Regulations in Title 14, *Code of Federal Regulations* (14 CFR) for fire protection of cargo impose certain burn-through requirements for liner materials (14 CFR 25.855). These burn through requirements only apply to the class C<sup>118</sup> compartments and not to the large main deck class E<sup>119</sup> compartments. Additionally, there are requirements for the certification of cargo compartments with aircraft-based smoke detection systems (14 CFR 25.858). Conversely, there are few requirements regarding fire protection for the design and materials used on cargo containers and how they impact the fire protection systems built into the aircraft, namely the smoke detection system.

It has been observed through visual examination of exemplars that the various types of cargo containers all have different paths from which smoke generated internally can exit the container and enter the space of the cargo compartment. None of these paths are designed intentionally for this purpose and they are simply artifacts of other design objectives. A visual examination of a large number of cargo containers at an air cargo sorting facility established that two types of cargo containers that may best exhibit the greatest possible range in cargo container fire performance are the rigid A2N<sup>120</sup> type container and the collapsible DMZ<sup>121</sup> type container. Rigid containers are mostly built using aluminum and polycarbonate panels and usually have some type of fabric door. The door area generally offers the lowest resistance to smoke egress from the container (figure 17). The A2N type container looks like it would not greatly impede the movement of smoke from its interior to the open space of the cargo compartment. The collapsible type of container is erected for use when needed, similar to a cardboard box. In use, the collapsible container is covered with an impermeable material to act as a rain and dust shield. These types of

---

<sup>118</sup> Class C cargo compartments have built-in fire suppression systems. These types of compartments are usually found on the aircraft's lower lobe.

<sup>119</sup> Class E cargo compartments do not have fire suppression systems and are typically large main deck cargo compartments.

<sup>120</sup> A2N is a cargo container size and configuration designation used within the United Parcel Service. The overall dimensions of an A2N container are 125" wide, 88" long and 81" tall.

<sup>121</sup> DMZ is a cargo container size and configuration designation used within the United Parcel Service. The overall dimensions of a DMZ container are 118" wide, 88" long and 95" tall.



containers, when covered, do not have well-established paths for smoke to pass through to the outside.

This portion of the study consisted of two test series, each with a different type of container (A2N and DMZ) to evaluate any delays in smoke egress from the containers from the time of the fire's initiation. Additionally, this portion of the study measured the time between when sufficient smoke egress from the container to activate an alarm and the time for the container fire to reach peak fire output.

The fire load chosen for these tests consisted of cardboard boxes containing 2.5lb of shredded paper inside. This is a fire load that has been used in past FAA fire tests and has been shown to be very repeatable. For example, the tests in the previous section of this study used arrays of 18 such cardboard boxes resulting in very good agreement between tests. Additionally, for future reference, since fire loads comprised of 18" cube cardboard boxes with 2.5lb of shredded paper inside are unofficially regarded as FAA "standard fire loads," experiments were performed on single boxes to quantify their total energy and energy release rate. These tests (appendix D) also exhibited good repeatability. Cargo containers can be packed with a wide variety of cargo shipments and the effect of that variability was beyond the focus of this study.

For all the tests conducted using cargo containers, a fire load consisting of 77 18" cube cardboard boxes with 2.5lb of shredded paper inside was used. The fire was initiated using a cartridge heater and a small fire log placed inside one of the cardboard boxes at floor level inside the cargo container. Measurements of energy release rate and total energy were made using an exhaust hood instrumented for oxygen consumption calorimetry. Heat flux measurements were taken at a distance of 60 inches from all four sides of the cargo container at a height of 66 inches from the ground. Temperature measurements above the container were made at distances of 12 inches, 24 inches, and 36 inches using type K thermocouples. In order to determine the time at which the smoke exiting the cargo containers would be sufficient to trigger an alarm from an aircraft's smoke detection system, the testing relied on two observers experienced in aircraft smoke detection system certification testing to make a determination of smoke concentration sufficient to trigger cargo bay smoke alarms.

## **2.a Rigid A2N container tests**

Two tests were performed using the A2N type of rigid cargo container (figure 16). This container type is constructed from aluminum and polycarbonate and has a fabric roll-up door. The A2N container was chosen because it was likely to exhibit the shortest delay in becoming a detectable fire and because its materials of construction provide the least contribution to the fire load.

The results from both tests were in good agreement with each other. The peak energy release rates were 3.6 MW and 3.7 MW and the total energy released was 1530 MJ and 1690 MJ for tests 1 and 2, respectively. With regard to the smoke generation and its ability to exit the container, the observations made are noted on the graphs depicting the energy release rate of each test (figures 18 and 19). The first signs of smoke were observed to be exiting from the top portion of the roll-up door as expected. Two noteworthy time

intervals are of particular importance. The first is the time between a fire being established inside the container and smoke beginning to exit the container in sufficient quantity to trigger an alarm, 199 seconds and 150 seconds for tests 1 and 2, respectively. The second is the time interval between the fire becoming detectable and the time to reach peak energy release rate, 450 seconds and 630 seconds for tests 1 and 2, respectively.



Figure 90: A2N type container with fuel load inside



Figure 91: Smoke exiting above roll-up door on A2N type container

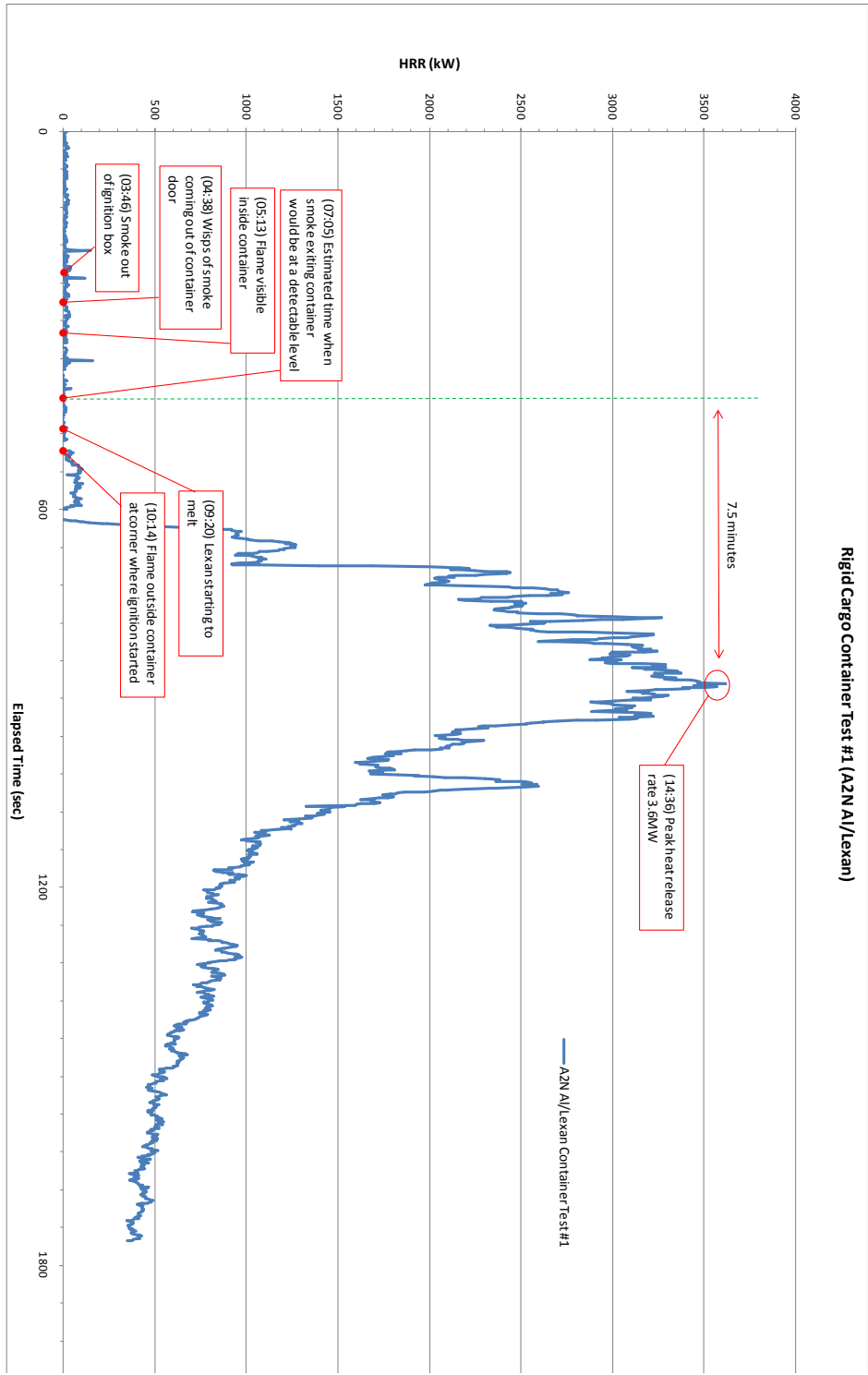

Figure 92: Energy release rate and observations from A2N container test 1

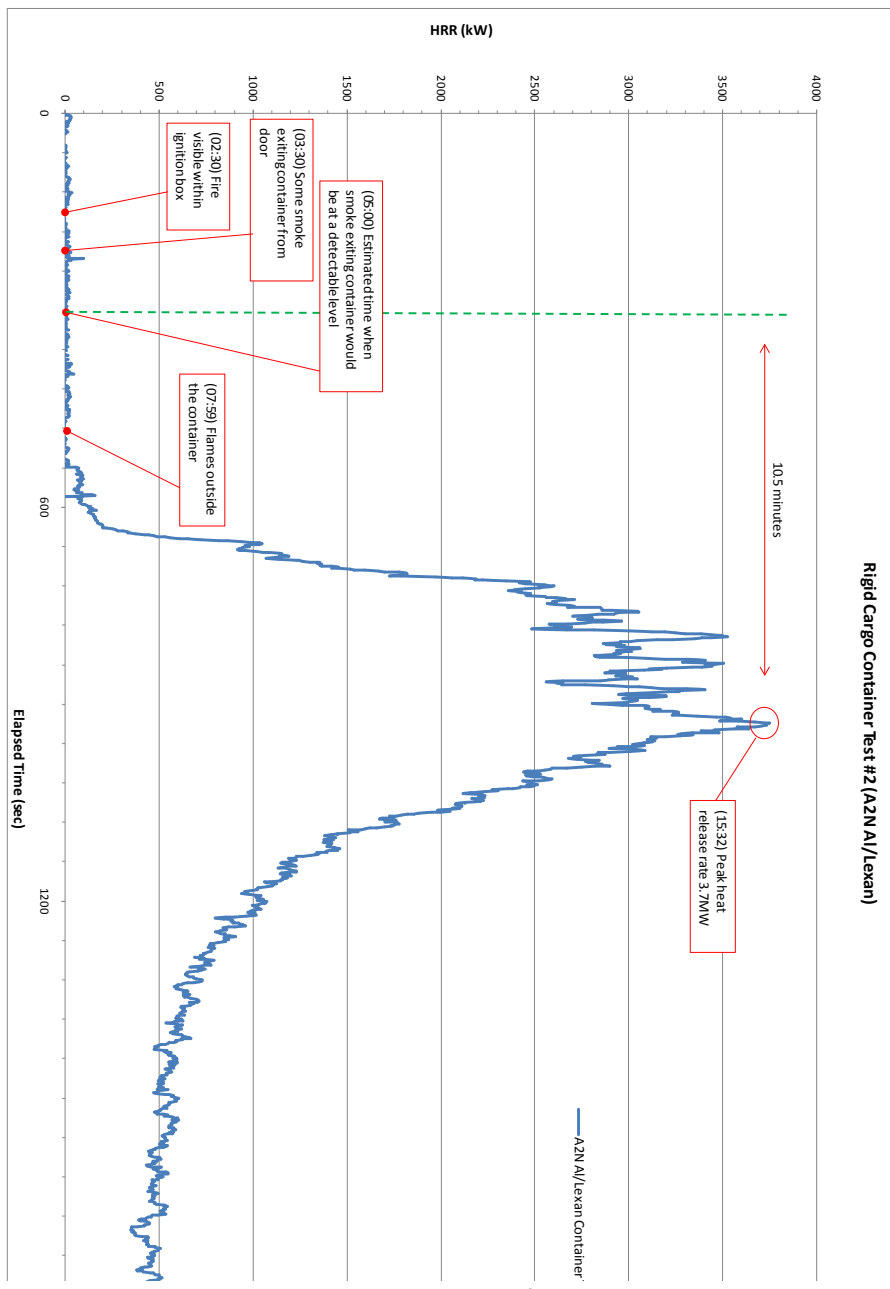

Figure 93: Energy release rate and observations from A2N container test 2

2.b C

Two tests were performed using the DMZ type of collapsible cargo container (figure 20). This container type is constructed from corrugated polypropylene and while in use is covered with a lightweight impermeable cover. This container type was chosen because it

was likely to exhibit the greatest delay in becoming a detectable fire and because the material of construction provide the most contribution to the fire load

The results show that the fire in the DMZ polypropylene container test #1, however, in the test box. The peak heat release rate was 8.45 MW, which was a relatively small total energy release. For the test, the total energy was 132 MJ. The fire rate of each test was monitored to determine the time to exit the container and the time to become buoyant and important. The fire in the container and the alarm, 18 minutes is the time between the fire starting and the alarm rate, 132 seconds

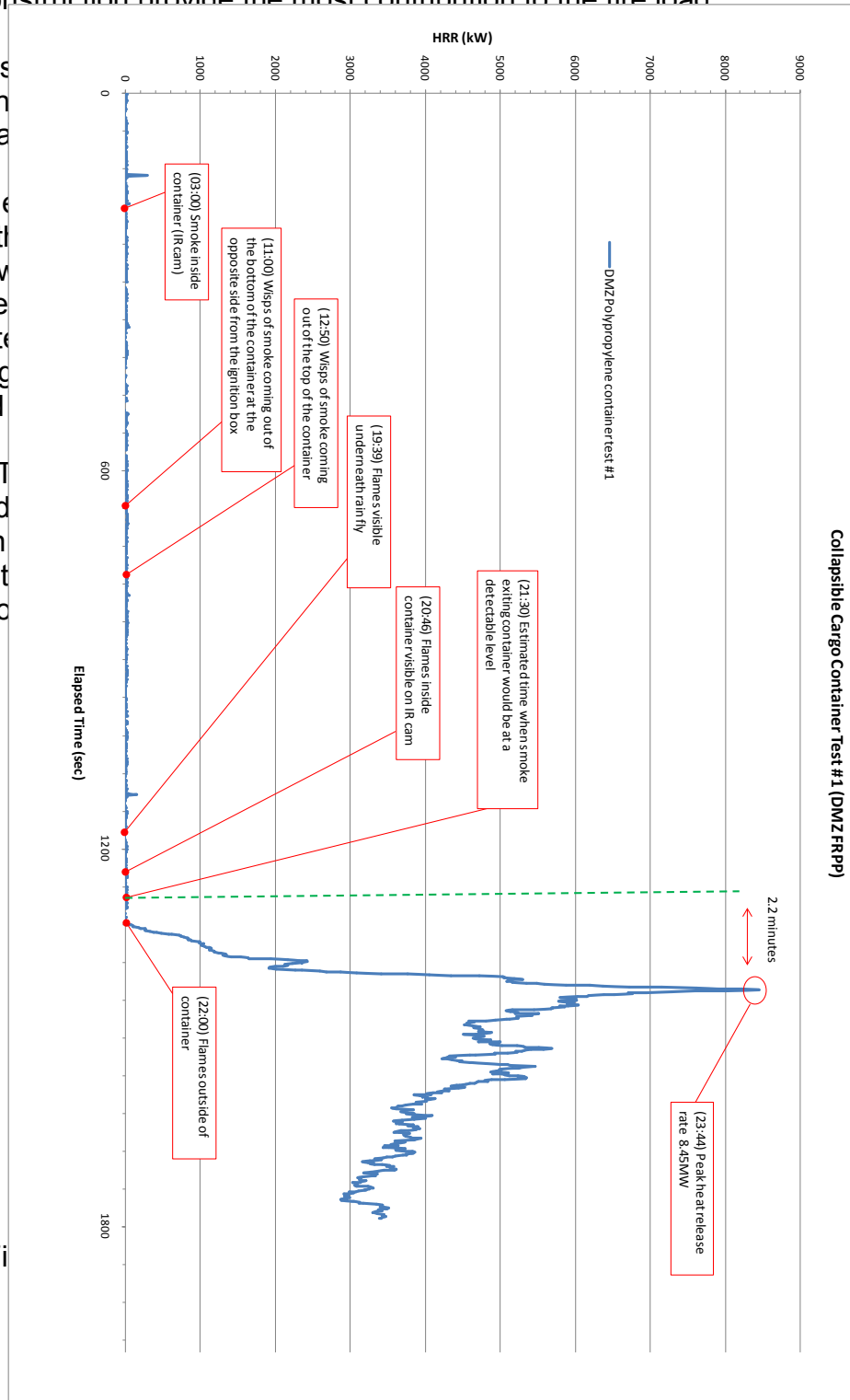

Fi

Collapsible Cargo Container Test #1 (DMZ FRPP)



each other; the ignition total energy and a relatively small amount of energy went into the measured fire to exit the container to become buoyant and important. The fire in the container and the alarm, 18 minutes is the time between the fire starting and the alarm rate, 132 seconds

Collapsible Cargo Container Test #2 (DMZ FRPP)

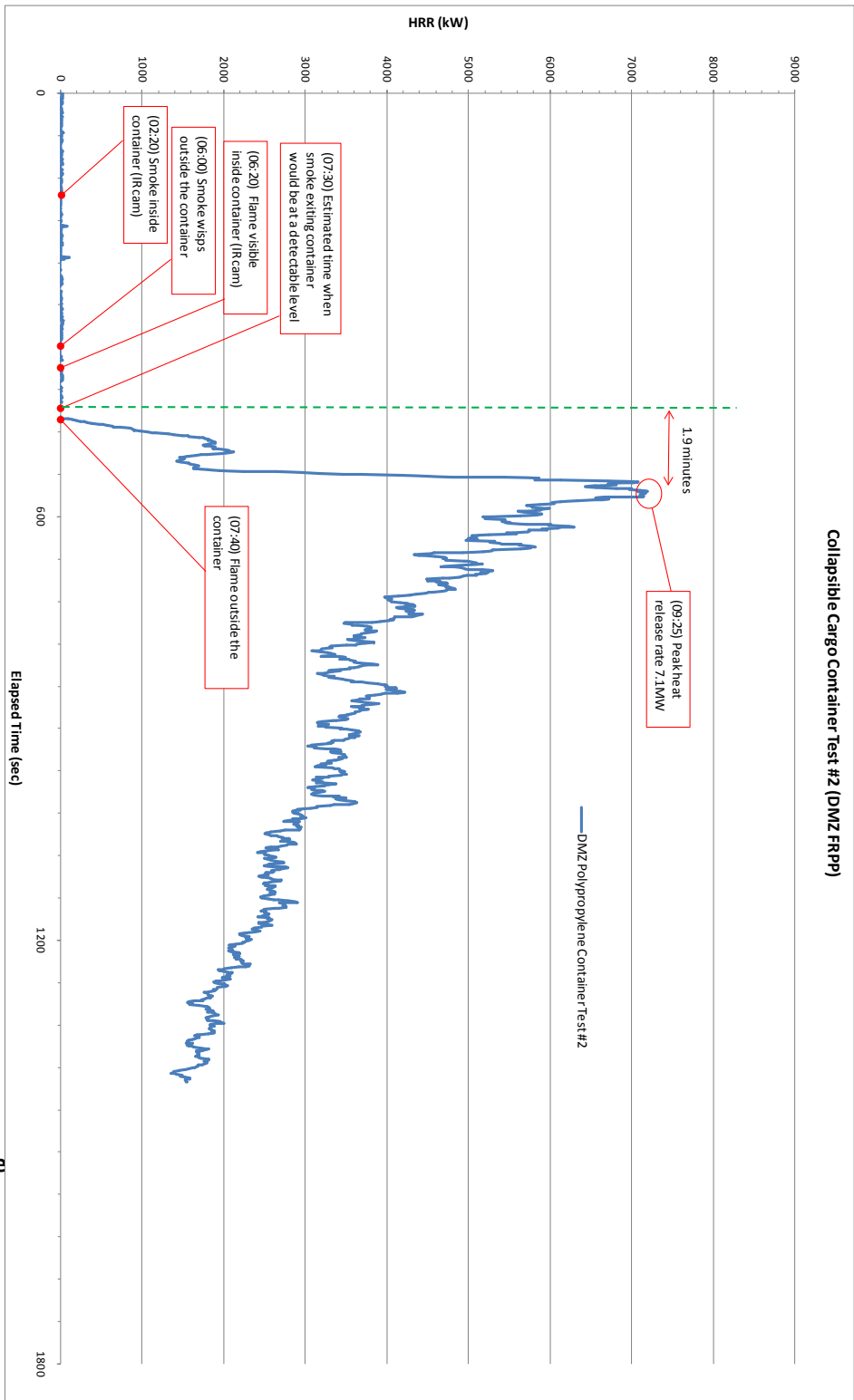

Figure

**Figure 96: Energy release rate and observations from DMZ container test 2**

### Summary and conclusions

The small scale tests involving single battery cells established values for the total energy release and the peak energy release rate for a few types of batteries when tested using the ASTM E1354 calorimeter. The total energy released per battery cell when normalized by the battery's weight is generally less than most ordinary combustibles. The peak energy release rate of the batteries did not appear to be influenced by the calorimeter's imposed heat flux to the battery samples. The batteries behaved more like balloons containing a flammable substance and, upon rupture of the balloon, quickly expelling the flammable contents as opposed to traditional materials whose burning rate is strongly dependent on the external heat flux they receive. The imposed heat flux did have a strong influence on the time to failure (or venting) on all the types of batteries tested.

In the intermediate scale tests conducted using single boxes containing 100 batteries each, exposed to a 30kW propane burner, the batteries increased the fire's energy release rate by approximately 90kW at the peak burning rate. This increase, based on the data from the small scale tests, was equivalent to seven battery cells failing simultaneously. During the test, while the batteries were venting, some of the burning batteries became projectiles, landing a few feet away from their original position.

In the intermediate scale tests conducted using single boxes containing 100 batteries each and an additional fire load of 18 cardboard boxes containing shredded paper, the batteries were found to be capable of spreading the fire to adjacent combustible materials. Upon causing ignition, the presence of batteries in the fire load did not appear to have an influence on the characteristics of the fire. Ignition of vented battery electrolyte caused an explosion, which resulted in the opening of the closure flaps of a cardboard box in which the box of batteries was placed. This explosion, which opened the box, allowed oxygen to enter, facilitating the combustion process.

Overall, from the small scale and intermediate scale tests, batteries of the 18650 lithium-ion type, either singularly or in small quantities, have the potential to initiate a fire while not adding significantly to the fire load and intensity of the fire. Lithium and lithium-ion polymer batteries behaved similarly in small scale single cell tests but were not tested at the intermediate scale level.

From the tests involving batteries, the following conclusions were made:

- At the single-cell level, the energy release rate of lithium and lithium-ion type batteries is relatively small when compared to other ordinary materials.
  - In addition to the energy release from batteries resulting in combustion, there is an associated mechanical energy release. This mechanical energy release is capable of compromising the integrity of packaging and creating incendiary projectiles.
- A.
- Lithium (primary) batteries tend to exhibit more energetic failures than lithium-ion (secondary) batteries.
- B.
- The total energy release of a box of 100 lithium-ion batteries can be fairly accurately predicted based on single battery cell calorimetry data.
- C.
- The thermal runaway of lithium-ion batteries is capable of spreading from cell to cell within a package of batteries.
- D.
- The thermal runaway of lithium-ion batteries is capable of causing adjacent combustibles to ignite.
- E.



The large scale tests involving cargo containers established the total energy release and peak energy release rate for a standard fire load using two different types of containers. Although the standard fire load chosen may not be entirely representative of what can be found in a container of commercial cargo, it is a start for assessing the threat to an aircraft from a cargo container fire. It was observed that, based on container design and method of usage while in operation, there can be a vast difference in fire performance from one container type to another. This difference was observed in both the time that it took for a fire inside a container to become detectable and in the overall size and growth rate of the fire.

In the two tests with the A2N containers, sufficient smoke to activate an alarm began to exit the containers at 3 minutes 19 seconds and 2 minutes 30 seconds, respectively for the two tests, after smoke was visible within the containers. In the two tests with the collapsible DMZ containers, sufficient smoke to activate an alarm began to exit the containers at 18 minutes 30 seconds and 5 minutes 10 seconds, respectively for the two tests, after smoke was visible within the containers. The FAA regulation for cargo compartments certified with smoke detection (14 CFR 25.858) requires a 1 minute detection time from the start of a fire. The regulation does not account for any delay in detection caused by the container. Current certification tests do not use containers.

The time interval between the time when sufficient smoke to trigger an alarm was exiting the containers to the time when the container fires were at their peak energy release rates was significantly different for the two types of containers tested. For the A2N containers, this time interval was 7.5 and 10.5 minutes, while for the collapsible DMZ containers, this time interval was 2.2 and 1.9 minutes. Particularly in the case of the collapsible DMZ containers, this short time interval between a fire being detectable and peak energy release rate precludes any mitigating action to suppress the fire and protect the aircraft structure. Although 14 CFR 25.858 for cargo compartments certified with smoke detection does not specify any performance metric for what goes on after detection, the results of these fire tests suggest that the intent of the regulation as stipulated in paragraph (b) of 14 CFR 25.858, "the system must be capable of detecting a fire at a temperature significantly below that at which the structural integrity of the airplane is substantially decreased," is not being met.

For the same fire load, the DMZ containers constructed out of fire-resistant polypropylene exhibited twice the peak energy release rate and total energy output than the A2N containers constructed out of aluminum and polycarbonate.

From the tests involving cargo containers, the following conclusions were made:

- Differences in container design and materials have a significant effect on fires originating within them.
- Container design has a significant effect on the time it takes for a fire to become detectable to an outside smoke detector.
- Container construction materials have a significant effect on the total fire load and energy release rate of a cargo fire.

- The time it takes to detect a fire originating within a cargo container exceeds the time specified in 14 CFR.
- The growth rate of container fires after they become detectable can be extremely fast, precluding any mitigating action.

Joseph Panagiotou  
Fire & Explosion Investigator

Appendix A (cover sheet of accompanying document shown)

## Data From Lithium, Lithium-ion and Lithium-ion Polymer Battery Fire Tests Conducted at the FAATC

These tests were conducted using the ASTM E1354 standard for oxygen consumption calorimetry. Single battery cells were used for these tests.

Date	Mfg	Battery Type	Voltage VDC	Radiant Heat Flux kw/m <sup>2</sup>	Initial Vent (sec)	Final Vent (sec)	Peak HRR kW	Total HR kJ	Mass loss (g)	Total HR/mass loss kJ/g	Total Mass (g)	Total HR/Mass kJ/g	Comments	Data file
3/30/11	LG	18650	4.03	10	731	N/A	0.2	9	4	2.3	43.6	0.2		11030027
	LG	18650	4.03	10										
3/29/11	LG	18650	4.03	30	165	242	13.7	84	10.3	8.2	43.6	1.9		11030029
3/29/11	LG	18650	4.03	30	165	242	9.8	76	12.6	6.0	43.6	1.7		11030030
3/8/11	LG	18650	4.03	50	109	159	10.2	100.2	10.1	9.9	43.6	2.3		11030010
3/8/11	LG	18650	4.03	50	96	137	16.2	92.8	9.6	9.7	43.6	2.1		11030011
3/8/11	LG	18650	4.03	75	56	75	12.3	81.6	9.1	9.0			No shield	11030009
3/8/11	LG	18650	4.03	75	83	82							No fare	11030004
3/8/11	LG	18650	4.03	75	50	71	16.2	92.6	9.1	10.2	43.6	2.1		11030006
	Titanium Innovations	CR2		10										
	Titanium Innovations	CR2		10										
3/29/11	Titanium Innovations	CR2	3.78	30	115	148	2.8	27	3.3	8.2	10.6	2.5		11030033
3/29/11	Titanium Innovations	CR2	3.24	30	118	161	3.1	32	3.2	10.0	10.6	3.0		11030034
3/8/11	Titanium Innovations	CR2	3.25	50	77	85	3.9	20.3	3.4	6.0	10.6	1.9		11030012
3/8/11	Titanium Innovations	CR2	3.2	50	90	118	3.7	33.1	3.5	9.5	10.5	3.2		11030013
3/8/11	Titanium Innovations	CR2	3.29	75	54	65	6.5	33.5	2.3	14.6	10.6	3.2		11030006
3/8/11	Titanium Innovations	CR2	3.26	75	54	70	4.2	31.4	3.7	8.5	10.8	2.9		11030007
	Sure Fire	SF123A		10										
	Sure Fire	SF123A		10										
3/29/11	Sure Fire	SF123A	3.23	30	104	149	4.2	42	4.7	8.5	16.3	2.6		11030031
3/29/11	Sure Fire	SF123A	3.23	30	113	149	3.6	55	8.4	6.6	16.4	3.4		11030032
3/8/11	Sure Fire	SF123A	3.23	50	74	94	3.9	52.2	4.4	11.9	16.5	3.2		11030014
3/8/11	Sure Fire	SF123A	3.23	50	69	89	4.7	73.5	4.4	16.7	16.4	4.5		11030015
3/8/11	Sure Fire	SF123A	3.23	75	48	68	5.9	64	3.8	16.8	16.4	3.9		11030008
3/8/11	Sure Fire	SF123A	3.24	75	52	67	3.6	44.6	4.3	10.4	16.4	2.7		11030008
3/30/11	Powerizer	PL-553562-10C	3.83	10	500	N/A	0.2	6	5.2	1.2	23.4	0.3		11030035
	Powerizer	PL-553562-10C	3.83	10										
3/29/11	Powerizer	PL-553562-10C	3.83	30	112	N/A	9.2	57	3.3	17.3	23.3	2.4		11030025
3/29/11	Powerizer	PL-553562-10C	3.83	30	130	N/A	8.9	47	2.9	16.2	23.2	2.0		11030026
3/29/11	Powerizer	PL-553562-10C	3.83	50	38	51	6	77	5.1	15.1	23.2	3.3		11030023
3/29/11	Powerizer	PL-553562-10C	3.83	50	48	63	5.7	75	5.6	13.4	23.3	3.2		11030024
3/28/11	Powerizer	PL-553562-10C	3.83	75	14	44	7.1	109	6.1	17.9	23.2	4.7		11030017
3/28/11	Powerizer	PL-553562-10C	3.83	75	22	31	5.8	97	7.2	13.5	23.3	4.2		11030018
3/30/11	Powerizer	PL-603495-10C	3.82	10	512	N/A	0.5	0	4.3	0.0	41.3	0.0		11030036
	Powerizer	PL-603495-10C	3.82	10										
3/29/11	Powerizer	PL-603495-10C	3.82	30	64	84	7.8	156	10.2	15.3	41.4	3.8		11030027
3/29/11	Powerizer	PL-603495-10C	3.82	30	88	88	7	145	9.8	14.8	41.5	3.5		11030028
3/28/11	Powerizer	PL-603495-10C	3.82	50	35	52	8	162	11.1	14.6	41.1	3.9		11030021
3/28/11	Powerizer	PL-603495-10C	3.82	50	35	58	5.8	147	11.1	13.2	40.8	3.8		11030022
3/28/11	Powerizer	PL-603495-10C	3.82	75	19	35	8.9	165	12.1	13.6	41.3	4.0		11030019
3/28/11	Powerizer	PL-603495-10C	3.82	75	22	39	7.4	170	12	14.2	41.3	4.1		11030020

Appendix B (cover sheet of accompanying document shown)



<b>Title</b>	Calorimetry- Box of Lithium Batteries		
<b>Test Type</b>	Custom		
<b>Lab Number</b>	NTSB-2	<b>Author</b>	Justin L. Rowe
<b>Test date</b>	8/9/11	<b>No. Tests</b>	2

### Table of Contents

Table of Contents.....	1
Introduction .....	2
Test Set Up .....	2
Experiment Details.....	4
Instrumentation.....	4
Results for Test 1 (Exp. ID 6552).....	9
Results for Test 2 (Exp. ID 6553).....	20

**NOTE: All dimensional measurements were taken in English units and were later converted to metric units. Any inconsistencies between the two units are due to rounding errors when the English units were converted to metric.**

Appendix C (cover sheet of accompanying document shown)



<b>Title</b>	Calorimetry-Eighteen Cardboard Boxes		
<b>Test Type</b>	Custom		
<b>Lab Number</b>	NTSB-3	<b>Author</b>	Justin L. Rowe
<b>Test dates</b>	8/8/11, 8/9/11, 8/10/11	<b>No. Tests</b>	4

**Table of Contents**

Table of Contents ..... 1

Introduction ..... 2

Test Set Up ..... 2

Experiment Details ..... 6

Instrumentation ..... 8

Results for Test 1 (Exp. ID 6548) ..... 12

Results for Test 2 (Exp. ID 6549) ..... 24

Results for Test 3 (Exp. ID 6557) ..... 35

Results for Test 4 (Exp. ID 6558) ..... 47

**NOTE: All dimensional measurements were taken in English units and were later converted to metric units. Any inconsistencies between the two units are due to rounding errors when the English units were converted to metric.**

Appendix D (cover sheet of accompanying document shown)



Title	Calorimetry- Single Cardboard Box		
Test Type	Custom		
Lab Number	NTSB-1	Author	Justin L. Rowe
Test dates	8/8/11, 8/9/11	No. Tests	4

**Table of Contents**

Table of Contents ..... 1

Introduction ..... 2

Test Set Up ..... 2

Experiment Details ..... 3

Instrumentation ..... 4

Results for Test 1 (Exp. ID 6539) ..... 9

Results for Test 2 (Exp. ID 6543) ..... 19

Results for Test 3 (Exp. ID 6544) ..... 28

Results for Test 4 (Exp. ID 6555) ..... 37

**NOTE: All dimensional measurements were taken in English units and were later converted to metric units. Any inconsistencies between the two units are due to rounding errors when the English units were converted to metric.**

Report Date December 28, 2011  
 Project NTSB-1

1 of 47

Appendix E (cover sheet of accompanying document shown)



<b>Title</b>	Calorimetry-Cargo Container Fires		
<b>Test Type</b>	Custom		
<b>Lab Number</b>	NTSB-4	<b>Author</b>	Justin L. Rowe
<b>Test dates</b>	8/10/11, 8/11/11	<b>No. Tests</b>	4

**Table of Contents**

Table of Contents ..... 1

Introduction ..... 2

Test Set Up ..... 3

Experiment Details ..... 5

Instrumentation ..... 8

Results for Test 1 (Exp. ID 6561) ..... 12

Results for Test 2 (Exp. ID 6562) ..... 26

Results for Test 3 (Exp. ID 6564) ..... 39

Results for Test 4 (Exp. ID 6565) ..... 52

**NOTE: All dimensional measurements were taken in English units and were later converted to metric units. Any inconsistencies between the two units are due to rounding errors when the English units were converted to metric.**

Report Date: December 28, 2011      1 of 63  
 Project NTSB Sub 4

References

- FAA Office of Security and Hazardous Materials. (2011, May 18). *Batteries & Battery-Powered Devices*. Retrieved 1 20, 2012, from [www.faa.gov: http://www.faa.gov/about/office\\_org/headquarters\\_offices/ash/ash\\_programs/hazmat/aircarrier\\_info/media/Battery\\_incident\\_chart.pdf](http://www.faa.gov/about/office_org/headquarters_offices/ash/ash_programs/hazmat/aircarrier_info/media/Battery_incident_chart.pdf)
- Webster, H. (June 2004). *Flammability Assessment of Bulk-Packed, Nonrechargeable Lithium Primary Batteries in Transport Category Aircraft*. Atlantic City, NJ: Federal Aviation Administration.
- Webster, H. (October 27, 2010). Lithium-Ion and Lithium Metal Battery Update. *2010 Triennial Fire and Cabin Safety Conference*. Atlantic City, NJ: FAA.





## E: NTSB SIMULATOR SESSIONS – SEATTLE

Simulator Test Results for UPS B747 Flight 6 Accident (NTSB # DCA10RA092)

Simulator: CAE Model 7000 Boeing 747-400F configuration

Airport (simulated): Seattle, WA (SEA), Alternate Portland, OR (PDX)

Participants (6): Simulator Operator: Tom Lange – Boeing

Left/Captain Seat: Darren Straker – GCAA

Right/F/O Seat: Martin Hinshaw – IPA

Observers: Katherine Wilson, Bill English – NTSB

Test Director: David Lawrence – NTSB

Date/Time: December 1, 2010/0500 PST<sup>1</sup>

Objectives:

1. To document crew procedures and the aural and visual alerts/messages that occur during pack failure and main deck fire events.
2. To document how crew performance is affected by modifying the font size of crew checklists and various lighting configurations, by removing outside visual references, and during single pilot operations.<sup>2</sup>

- Notes:**
- The crew consisted of 1 GCAA pilot (non-rated B747) sitting in the left/Captain's seat and 1 UPS B747 rated line captain sitting in the right/First Officer's seat.
  - For the main deck fire scenarios, Seattle (SEA) was used to simulate Dubai (DXB) and Portland (PDX) was used to simulate the diversion option of Doha. Based upon FDR data, the SEA 210 radial at 120 miles (PBD01) was used as the point for initiation of the main deck cargo fire.
  - The simulator was configured with UPS oxygen masks and smoke goggles.
  - Only UPS checklists/procedures were used to complete scenarios.
  - Smoke was generated via an internal system to the simulator and a handheld smoke generating device.<sup>3</sup>
  - Task times are approximate to the minute and were noted when necessary.

---

<sup>1</sup> All times listed are Pacific Standard Time (PST) unless otherwise noted.

<sup>2</sup> The purpose of this test was not to conduct a systems verification check or replicate any degraded flight control functioning.

<sup>3</sup> See Appendix A for more information on simulator set up/clean up and smoke generation.

## Initial Setup

- FMS Flight plan - SEA-SEA/210/120DME (PBD01)-HNL<sup>4</sup>
- Departure/Destination - SEA/HNL
- Alternate - PDX
- Weight - 750,000 pounds
- Autopilot - Engaged, standard VNAV climb to FL320
- Config - Clean
- Altitude -20,000 feet
- PF/PM - F/O will be PM and Captain will be PF
- Weather - Night VFR, calm winds (preset for all tasks)
- Sim Position - Instructor: take a “snapshot” of Task 1 position

## Procedure

- 1) Boeing provides simulator safety briefing.
- 2) Observer/pilot occupant cockpit familiarization.

**Note: Task complete when simulator occupants briefed**

## Initial Setup

- Weight - Normal Climb to FL320
- Autopilot - Engaged
- Config - Standard
- Pressurization - Auto

## Task 2 - Pack Failure

Procedure	Notes
1) Simulator motion “on”.	Time: 0649
2) Pack 1 failure.	Time: 0653 Captain was PF; Pack Failure checklist accomplished by F/O.
3) Document visual/aural alerts.	No aural alerts noted; “Pack 1” message appeared on EICAS in top right.
4) Time from pack failure to status message.	Status message appeared on EICAS about 20 seconds after failure initiated.
5) Transfer control; complete QRH items.	F/O became the PF about 1 minute 5 seconds after the start of the failure. Crew turned on dome light to complete checklist.
6) Time for pack to reset and status message alert to extinguish.	Time: 0655 Status message extinguished about 2 minutes 25 seconds after initiation of QRH.

<sup>4</sup> Honolulu International Airport, Honolulu, Hawaii

7) Task complete when Pack 1 resets. Freeze simulator.	
--	--

### Initial Setup

- Departure Point - SEA
- Destination - SEA/270/120 DME
- Alternate - PDX
- Weight - Standard, Normal Climb Thrust Setting
- Autopilot - Engaged
- Config - Clean
- Altitude - 20,000 feet + (during climb to FL320)
- Sim config - Continued flight after pack one reset, normal climb
- Pack one - Reset to operational
- PM/PF duties - PM (Captain) will run all checklists, radio calls, and MCP inputs

### Task 3 – Main Deck Fire Scenario

Procedure	Notes
1) Initiate Main Deck Cargo Fire upon arrival at PBD01.	Time: 0659 Aural alarm.
2) Don O2 masks/goggles; establish communications.	Time: 0700 Pilot notes goggles a bit tight and irritating after 10 minutes of wearing. Periphery was limited and had to push goggles closer to face to get greater periphery. Pilot notes the emergency switch was easy to find but the normal/100% switch hard to find and he thought it was on opposite side of mask.
3) Use current MDF checklist. <b>NOTE: DO NOT press the “Depress” switch<sup>5</sup></b>	Time: 0701 Transfer control – Capt. is PM; F/O is PF Pilot notes that while crews don oxygen masks in flight, they do not communicate while wearing the mask because they wear the mask when they are single pilot. Pilots only communicate while wearing the mask during initial training. 0702: pilots depress MDF button. 17 seconds later, visual alert on EICAS.
4) Initiate smoke in simulator.	Time: 0702
5a) Time MDF alert to start of checklists.	Less than 2 minutes.
5b) Time MDF alert to don O2 masks/goggles.	Less than 1 minute.
6) Task crew to divert to SEA	Time: 0704

<sup>5</sup> Pushing the DEPRESS switch would evacuate smoke from the simulator.

Procedure	Notes
via FMS entries.	SEA Runway 34R (ILS 110.3, 343° inbound) 11 FMS entries made. Pilot also changed destination.
7) Pilots reach separately for smoke evacuation handle.	Time: 0708 Both pilots easily found the smoke evacuation handle. PF believed airplane was at 10,000 feet, however, they were still descending through FL190. The displays were visible to observers not wearing goggles but PF could not see displays through smoke and goggles. PM noted that he could not see PF.
8) Give multiple radio calls.	Pilots had to lean to see panels. One pilot stated that he could not see the screen. Crew had communication issues and said it was hard to remember that it was not a hot mic in the mask. One pilot indicated that his hand was “tied up” to activate the mic. Pilots noted that they could see better with the dome light off. PM asked for an altitude from ATC.
9) Task complete upon arrival to 10,000 feet. Freeze simulator.	

**Task 1 - Setup**

**NOTE: This task occurred during the descent phase of the previous task (Task 3).**

**Initial Setup**

- Simulator position - Position freeze aircraft during descent in Task 3 (if required, no later than 10,000 Feet)

Procedure	Notes
1) Ensure simulator is smoke-filled.	Time: 0713
2) Compare current/larger font MDF checklists (dome light on).	Current checklist: Pilots could not read QRH through smoke. Larger font: Pilots indicated that it was still hard to see but it was easier than the smaller font. Both pilots indicated dome light on was worst for reading checklists.
3) Identify visible primary flight displays/MCP/FMS and radio panels.	PF could read displays if he put his head close. He could see “bits and pieces” of the PFD but no specific information. He could not see what he was dialing on the MCP. PM could feel the buttons of the MCP but could not see anything. He could see the blue background of the PFD but not details.

4) Identify visible EICAS status messages and visual warnings.	PM could see that the CDU had green lettering and could only make out a few letters.
5) Compare current/larger font MDF checklists (dome light off).	Both pilots said it was easier to view the checklists without the dome light on.
6a) Compare current MDF with larger font checklist (simulated daylight).	Both pilots said it was a little better to view the checklists without the dome light on but they could not make it out.
6b) Identify visible primary flight displays/MCP/FMS and radio panels (simulated daylight).	MCP caught smoke under panel lip which did not occur on the PFD. PM noted that he could see the green lettering of the CDU/FMC better through the smoke but it was still not readable. PF noted that the pressure from the O2 band on back of head was starting to hurt.
7) Compare current/larger font MDF checklists (white flashlight).	PF noted that the smoke and the background of the checklist were the same color (white) so text was hard to see. Also with the white flashlight the contrast made it hard to read. Like “high beams” or “white out”.
8) Compare current/larger font MDF checklists (flashlight with red filter).	PF said the larger lettering was easier to read because better contrast. PM said he could see more lettering with larger font and red filter. When lots of smoke, size didn’t matter. But when the smoke cleared slightly, PM said larger font was more visible (a few letters could be seen and a word could be inferred).
9) Task complete when crew observations are complete. Freeze simulator.	

- Masks/goggles - On
- Dome light - On
- Checklist - Provide crew with larger font checklist
- Flashlight - Provide crew with hand-held flashlight

#### **Task 4 – Visibility Drills**

##### **Procedure**

- 1) Set simulator on position freeze
- 2) Push “Depress” switch to evacuate smoke
- 3) Exit simulator and allow cab to clear of smoke
- 4) Reset sim position to Task 1 “Initial Setup”
- 5) Provide crew with larger font MDF checklist

## Task 2 - Pack Failure

### Initial Setup

- Sim Position - Instructor: reposition sim to Task 1 “snapshot”
- FMS Flight plan - SEA-SEA/210/120DME (PBD01)-HNL
- Departure/Destination - SEA/HNL
- Alternate - PDX
- Weight - ~750,000
- Autopilot - Engaged, standard VNAV climb to FL320
- Config - Clean
- Altitude - 20,000 feet
- PF/PM - F/O will be PM and Captain will be PF

Procedure	Notes
1) Initiate a Main Deck Cargo Fire upon arrival at PBD01.	Time: 1037 35.5 seconds from alarm to pack message on EICAS. Volume of intercom was turned down to see how long it would take crew to notice reduced speaker volume. Neither pilot recognized that the volume knob was turned down after they donned the O2 masks. Observers could hear both pilots through both speakers, but the volume was noticeably lower than before. <sup>6</sup>
2) Initiate smoke in simulator.	
3) Don O2 full face masks/goggles; establish communications.	Communications established 55 seconds after start of scenario. Pilots note full face mask easier to don and more comfortable. Control transferred by 14 seconds from start of scenario.
4) Use MDF checklist with <b>larger</b> font. <b>NOTE: DO NOT press the “Depress” switch.</b>	Captain is PM; F/O is PF. PM distracted from checklist because of ATC radio calls for about 1:44. Dome light on.
5a) Time MDF alert to start of checklist.	PM grabbed checklist 7 seconds after start of scenario. Time from MDF arm to pack message: 35.5 seconds.
5b) Time MDF alert to don O2 masks/goggles.	Masks donned 33 seconds after start of scenario. Actual donning took 6 seconds. Pilots could make out blue on PDF and green displays best. PF could not see MCP. PF could not make out any details with black background and said status messages on EICAS were too small to read.
6) Divert to PDX. Provide vectors for an approach to PDX runway 10R. (ILS 110.5, 101° inbound)	Dome light turned off. PM again distracted by ATC radio calls. 6 FMS entries to divert.
7) Attempt autoland at PDX.	3:09 into scenario, aft cargo fire alarm occurs. Pilot notes that he can’t see what the alarm is. Crew was leaning to see panels. PM asking ATC for DME and altitude.

<sup>6</sup> According to the FCOM, turning the volume down on the intercom is not affect the speaker volume, which is only influenced by the speaker volume knob.

8) Task complete at instructor's discretion (no later than 15,000 feet). Freeze simulator.	PF noted he had better vertical vision but not lateral/peripheral vision when wearing the full face mask. Mask more comfortable than separate system. PM noted he had better lateral and vertical vision. Pilot in right seat could lean forward as far as the altitude window on MCP. Pilot in left seat could lean forward as far as the heading window on MCP.
--	---

- Weather - Night VFR, calm winds (preset for all tasks)

**Note: Full face mask<sup>7</sup> installed in simulator during break and used for remaining scenarios.**

**Task 5 – Alternate MDF Checklist**

**Task 3 – Main Deck Fire**

**Initial Setup**

- Simulator position - Position freeze aircraft
- Masks/goggles - On; full face mask used
- Dome light - Off
- Checklist - Provide crew with larger font checklist
- Flashlight - Provide crew with hand-held flashlight

**Task 6 – Visibility Drills 2**

Procedure	Notes
1) Ensure simulator is smoke-filled.	Dome light off. Pilot had difficulty finding MDF checklist because of small tabs on QRH.
2) Compare current/larger font MDF checklists (dome light).	Small: PM said dome light not much better than using the white flashlight. Large: PF said the white background of the checklist with the white smoke made it difficult to read. PM said dome light refracted the light.
2) Compare current/larger font MDF checklists (white flashlight).	Small: PF said smoke was more reflected with the white light. PM said white light was a lot worse. Large: PF said the white light was reflected on the smoke. PM said he could not make out the black writing.

<sup>7</sup> See Appendix B for pictures



Procedure	Notes
3) Compare current/larger font MDF checklists (flashlight with red filter).	Small: PF could differentiate words better through smoke. PM could tell there was writing but could not read the text unless there was a break in the smoke. When dome light turned on and red flashlight used, PM said it was better because it penetrated the smoke better. Large: PF could make out main words better. PM said it was better and more readable. Both pilots said with dome light on and red flashlight it was much easier to see/penetrated smoke better.

## Task 4 – Visibility Drills

### Initial Setup

- Simulator position - Position from Task 5 (10,000 feet)
- Autopilot - Engaged
- Masks/goggles - On
- Pilot duties - F/O will be PF, Captain will not participate in this task
- Config - Clean
- Altitude - 10,000 feet
- Dome light - Off

### Task 6 - Ditching/Single Pilot CRM

Procedure	Notes
1) Initiate smoke generation in the simulator.	Time: 1109
3) Place simulator motion to "on".	
2) F/O completes "Ditching" QRH action items.	Time: 1113 Crew dumped fuel. Turning up brightness of PFD helped visibility some. PF stated he was completing items from memory because he could not see anything.
4) Task F/O to ditch aircraft.	

Procedure	Notes
5) Task complete at instructor's discretion (Do not allow aircraft to impact). Freeze simulator.	

Pilot Observations and Conclusions:

Donning of the emergency oxygen mask (UPS standard):

- i. Straight forward, however, determining the position of the oxygen selector with the mask on is difficult without experience
- ii. Changing the selector from a predetermined position to an alternative position – e.g., from normal to 100% in an emergency condition is only possible if all other tasks are terminated and the crew member concentrates on the specific task of manipulating the selector.
- iii. Changing from normal or 100% to emergency flow is a task that requires detailed familiarity as it is performed without visual reference. It is an acquired skill that requires repetitive practice to familiarize the procedure as an instinctive reaction.
- iv. Prolonged operations with the mask on can be difficult to sustain due to the build up of sweat effecting the mask placement; it was also noted the due to the high stress a noticeable build up of saliva affects the mask functioning (it requires clearing from the mask)
- v. Two piece smoke goggle/mask take longer to put on.
- vi. A lot more "action" is required to move switches in position for the smoke prevention.
- vii. Two piece is harder to adjust once on, because you can't adjust the mask without removing the goggle because the goggle strap hold the mask strap against the head and won't allow the mask band to expand to allow a different fit.

Donning of the emergency oxygen mask (full face):

- i. Straight forward, simple process without the complication of also donning the mask and performing the mask clearing procedure(see below).
- ii. Similar difficulty exists for determining the normal,100% and emergency switch positions.
- iii. One piece mask is a lot faster to put on. The extra time can be used to set up audio panel.
- iv. One piece is a lot more comfortable. You can move the mask for a better fit and both, the mask and goggle, stay together, never breaking seal.
- v. The vision on the bottom half of the goggle is far superior in the full face. It allows to see the center console without putting your chin against your chest or even pulling down on the hose to see and that takes a hand that you may not have available for that task.
- vi. It feels lighter, and maybe that is due to the fact there is NO hot spots on your head since only one strap holds both, the mask and the goggle.

Donning of the emergency goggles:

- i. Problematic to get the goggles to fit and then sit on the oxygen mask. The oxygen mask retainer prevents the goggle attachment strap from seating properly.
- ii. The smoke goggle strap, applies pressure to the oxygen mask strap against the skull and creates hot spots that are distracting after 5 minutes.
- iii. There is a prerequisite that the wearer has to know that the mask selector top vent has to be pulled down to provided the goggle clearing function.
- iv. Performing the goggle clearing function is not intuitive, but is a learned process which is not easily performed in a high stress, multi tasked environment.
- v. Lateral and downward vision lost when goggles put on.
- vi. Difficult to see radio panels comfortably with the mask and goggles on. Had to pull mask down to see radios.

#### Establishing Communication:

- i. Without a hot mic function, crew communication is achieved through either the control column mic switch (left hand Capt/right hand FO) or the RT/INT switch on the radio panel (right hand/left hand). One pilot indicated that it depended on what he was doing at the time as to which switch was used. With the task breakdown and crew functioning during an emergency, the necessity to arrest the task, perform the communications requirement and continue with the assigned task is diverting and the synchronization of the crew tasks can become problematic to crews unfamiliar with the drills required.
- ii. In the absence of a defined verbal command or confirmation, non-verbal associative actions were observed to complete the assigned task or drill.
- iii. In multi-task functioning environments, the communication switching is not an intuitive function.
- iv. An associative problem with the communication switching is the cessation of the assigned task for the duration of the communication requirement. In a high task load situation, this is a diversion activity inside the CRM procedure.
- v. Without a clear role and function differentiation in the CRM process, i.e. PM verses PF responsibility, this task completion as per the non normal checklist is not a priority (based on observation).
- vi. When going to either system (1piece/2 piece) you must set up the audio panel, and that does take some time to establish communication. You are as fast as your partner, and you can't establish communication until the last person comes on. Just like the HOT AUDIO for the 121.5 radio, I would like to see when the mask is pulled out, audio panel is set up for operation. Forces volume and speaker on.

#### Maintaining Communication:

- i. In a normative flight deck environment without degraded visual acuity, communications are straight forward as the crew can refer to task actions through verbal and non verbal commands – pointing for example.

- ii. In a smoke degraded cockpit without line of sight to the other crew member with high demand on task completion and ergonomic limitations imposed by utilizing one hand to periodically manipulate the mic switch(s), task completion and communication functions are counterproductive. It was observed that following a specific command – speed break extend – if the command was not completed as the task was enunciated, the PF made the action to complete the task
- iii. In the multitasked environment each crew member performed the allocated task up until one crew member considered a new task priority took precedence over the current tasking, eg MCP inputs versus comms with ATC.
- iv. Not having hot mic is a huge handicap. You are now communicating in a "bad" environment and you have to change habits. Every time you want to say something to your crew, it takes one hand and a button. You can't just have a duplex conversation like you would normally have. Not having the hot mic options adds a lot of effort and confusion to the existing problem. Communication is KEY to this non normal and not being able to talk while using your hands for other tasks, adds to the emergency.
- v. Without hot mic, the PM ends up doing the checklist without verbalizing what he is doing to save time on accomplishing the procedure but also leaving the PF out of the loop on what the PM is doing. You can't see what the person is doing and you can't hear either and that is a bad combination.

#### Visual Clarity:

- i. In normal crew function modes a response to an alert message is 'Visualize, Comprehend, React, Solve'. If it is not possible to visualize the message (reading the EICAS), the resulting chain of the problem solving is rendered redundant. It is possible to comprehend an audible warning in a visually degraded environment, but with the specific fault or error message being visible, the possibility to solve the problem is seriously diminished.
- ii. Inter-crew functioning in a completely smoke filled cockpit compromises the safety and failsafe loop as non-linear task completion in conjunction with elevated task demands will ultimately arise in the two crew members functioning independently
- iii. Checklist reading in a degraded cockpit was problematic. In the case of UPS6, the aircraft departed prior to CET, climbing on a westerly heading. This is significant as the cockpit conditions would have been dusk, with ambient solar illumination. On the return, post CET, descending easterly, there would have been less or no solar illumination. As the juncture between the external light source and the cockpit light requirements may have meant that the checklist started in relatively bright conditions, in a smoke filled cockpit, it was determined that turning off the dome light aided the checklist reading as the light was not refracting through the smoke.
- iv. Reading the checklist in twilight conditions, smoke in the cockpit visual acuity is enhanced with a red filtered light as the definition of the black printed words are easier to differentiate in a smoke filled cockpit.

- v. It was noted that the Flight Management Computer (FMC) green on black illumination was easier to distinguish
- vi. It was noted that blue – as on the PFI – was easier to distinguish than surrounding colors
- vii. The large scale non normals checklist was easier to read than the standard checklist, particularly under red light
- viii. In the thickest smoke, only Braille will help. What bigger font does to you, if there is any "break" in the smoke, it allows you to see more letters (group), therefore part of words. From that you can deduct what the action on the checklist is for the next step.
- ix. Larger font allows the finger to hold the position on the checklist where you just were able to catch a glimpse and wait for the next break in the smoke waves, to continue reading the checklist.
- x. Smoke is like fog and it can go from RVR 0 - 2400. So the term smoke doesn't cover the spectrum to describe what you can do or are able to see. When smoke was zero zero, I would not see ANYTHING outside my plastic visor, light or no light.
- xi. Except for the ZERO ZERO big font can make the difference in accomplishing the checklist faster and accurately.
- xii. Having ink that can reflect with little light might help in a dark cockpit (for electrical loss checklist at night) and smoke environment checklist.
- xiii. For newer aircrafts that have checklists on a MFD, the smoke or electrical QRH might still need to be on a card so you can see.
- xiv. It was very apparent that the dome light (white and bright) refracted in a major way, and basically turn the cockpit into a "flash". It is like driving in fog/heavy snow fall and using the high beams.
- xv. Softer color, light red allowed light to see what we were doing but did not blind us. A red dome light might be a good option.
- xvi. Flash light with a red lens also worked better, but with this environment of having one hand to hold the push to talk, and the other a flashlight, you have nothing else to do the job.

#### Cockpit Resource Management:

- i. When the cockpit visual clarity was compromised the task and roles between the PF and the PM also exhibited a reduction in efficiency.
- ii. The communications function when task loaded are not a priority due to the ergonomic constraints of mic switching and freeing up one hand for the task is counter intuitive and counterproductive to the task completion – e.g., MCP task completion verses ATC comms or reprioritizing associated tasks which can then be unintentionally discarded

#### Conclusions

- i. It is imperative that when cockpit visual clarity is compromised, clear and defined task and role differentiation between the PF and PM are understood and reinforced through adequate training.
- ii. Crews should be very familiar with the functioning of the oxygen mask selectors and the switching options, including the mask venting function

- iii. Turning off the dome light aids text differentiation in smoke + twilight conditions
- iv. EICAS messages that cannot be read are a fundamental flaw in the smoke filled cockpit checklist design philosophy
- v. Reversion to a variation of single pilot CRM appears to be a standard reaction to a lack of communication in multi crew operating environments. It would be advisable that if 1 crew member goes into a single pilot CRM state of cognitive functioning, that the actions performed are enunciated (as per normal 1 pilot CRM) to provide a clue to the PM, or non-handling pilot, that a command decision has been made and the PM should revert to a passive or supernumerary role.
- vi. Training for worst case scenario emergency flight management should be predicated on the requirement to perform an immediate landing with degraded cockpit visibility and communications. This should be a rehearsed procedure with the decision points clearly established through repetitive training
- vii. Checklists should be fully representative of the reality of the emergency they are attempting to mitigate.

### **Appendix A**

Smoke Test in Boeing simulator, Bldg 25-01, Tukwila, WA      Nov-Dec 2010

Simulator utilized: CAE Model 7000 B747-400F configuration

-Smoke generation is provided through 2 simulator malfunctions:

--Electrical: 3 panel areas of smoke production

--Air Conditioning: Smoke production from each of the three Packs

-Smoke generation is for training purposes to introduce realism (fumes and wispy smoke); does not restrict visibility.

When utilizing malfunctions generating smoke, the building fire detection panel goes into by-pass for that particular simulator.

-When accomplishing the Fire Main Deck non-normal checklist, the DEPRESS switch was not pushed. Doing so would evacuate the smoke from the simulator.

Additional smoke was required for the purpose of the GCAA/NTSB test. For the smoke generation scenarios, a smoke generator approved for certification flight tests was used – See the information below:

The Smoke generator is a Colt, model COLT4BASIC. The fluid is Corona Type 100A. <http://msds.web.boeing.com/cics/suw1/s11ow003> Search for MSDS# 108720



The simulator has ventilation that could allow Colt-generated smoke to escape from the simulator and possibly be vented to the simulator bay. During the smoke scenarios, utilizing the Colt smoke generator, the Boeing Fire Department was on-scene to monitor for any smoke. To prevent an interruption in training from the other simulators, the building's smoke and fire detection panel was placed in by-pass, and the on-scene firefighters visually monitored the 747F simulator.

The smoke generator was not able to completely fill the simulator with smoke because of the required simulator ventilation. The smoke was effective, however, by placing the generation nozzle in the area of interest, as in, which pilot was to accomplish which task. This appeared to be an effective method in simulating a dense smoke environment.

After the tests were completed, the simulator smoke evacuation fans were used to eliminate the smoke from the simulator and to prevent smoke from entering the simulator bay. The fans required approximately 10 minutes to evacuate the smoke.

At the completion of the smoke scenarios, simulator maintenance personnel required almost one hour of clean-up time. The smoke generation fluid leaves a film on many of the surfaces, as well as the mirror from the visual generation system.

## Appendix B

Use of full face mask in the simulator.





**NATIONAL TRANSPORTATION SAFETY BOARD**

Office of Aviation Safety

Washington, D.C. 20594

July 19, 2011

**OPERATIONAL FACTORS/HUMAN PERFORMANCE  
SPECIALIST REPORT TO THE U.S. ACCREDITED  
REPRESENTATIVE**

DCA10RA092

- This is an extract from the NTSB report, abridged from the original report -

**Anchorage Simulator Observations**

The Group participated in an observational study at the UPS Training Facility in ANC on September 13, 2010. The purpose of the study was to familiarize the group with checklists and procedures related to smoke and fire scenarios that may occur in-flight. The simulator used for the observations as an FAA certified level D B747-400 simulator. Three pilots who were type rated, current and qualified on the B747-400 participated in this study. In addition there was a simulator instructor and 4 observers from the operations/human performance group.

Simulator Session #1 set up:

Altitude: FL320

Location: 148 NM from ANC

Heading: 180 degrees away from ANC (heading of about 240)

Weather: clear skies, unlimited visibility, winds calm, night

Pilot flying (PF): first officer/pilot #2; Pilot monitoring (PM): captain/pilot #1

Scenario #1a: FIRE MN DK FWD warning followed by smoke in the cockpit within 30 seconds of warning.

Summary of observations<sup>8</sup>

Prior to beginning the scenario, the flight crew checked oxygen mask and smoke goggles per UPS procedures. Pilot #2 stated that most pilot do not know about the valve on the oxygen mask that must be activated to clear the goggles of smoke. The pilots and observers were briefed on the UPS initial B747-400 simulator session 6 which focused on the smoke, fire and fumes checklist.

The scenario began as the flight crew reached their top of climb after departing ANC. The flight crew received a “fire main deck forward” warning. The first officer remained as the pilot flying and the

---

<sup>8</sup> Times noted in observations were based upon elapsed time from the beginning of the scenario..

captain called for the fire main deck checklist. No emergency was declared and no turn was initiated. The FIRE MN DK FWD checklist was begun at about 1:32 (1 minute and 32 seconds into the scenario). When pilot #1 removed his oxygen mask from its container, the cord was tangled and delayed donning. Two minutes and 15 seconds into the scenario, an emergency was declared with ATC (air traffic control). The flight was cleared to descend to FL250 and initiated a right turn toward ANC. Although “smoke” was declared by the instructor, it was not heard by the flight crew and no acknowledgement was made. When the main deck cargo fire arm switch was armed, packs 2 and 3 were automatically turned to ‘off’. It was unclear to the observers who was designated the PF because pilot #1 switched the altitude in the mode control panel. The flight crew was again informed that the cockpit was full of smoke at 4:18 into the scenario. The flight crew donned smoke goggles. It took about 16 seconds for the crew to don their smoke goggles. The flight crew descended to FL100. At time 5:30, the flight crew was unable to see their instruments due to smoke in the cockpit. This was simulated by failing the displays and covering the backup display. The captain pulled the smoke handle, however, no checklist was used to make this decision.

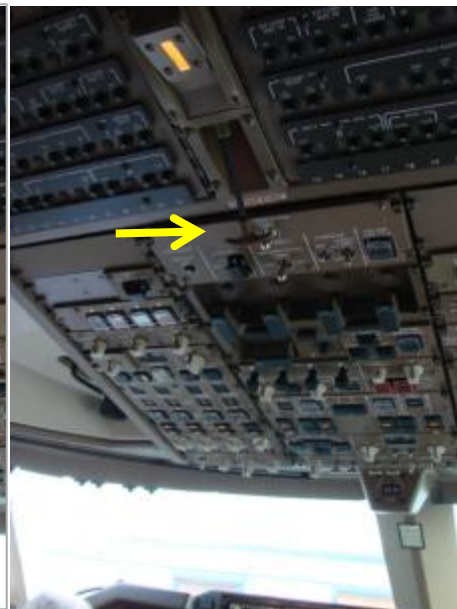

Figure 97: Smoke Evacuation Handle      Figure 98: Smoke Evacuation Handle (pulled)



Figure 99: Smoke Evacuation Handle      Figure 100: Smoke Evacuation Port (cockpit ceiling)

At time 8:20, the captain began the smoke or fumes removal checklist. The flight crew received a “terrain” warning at about 4800 feet but recovered by initiating a climb to 7000 feet. The instructor used flight freeze at 11:55.

#### Summary of debrief

The pilots involved in the exercise indicated that with the smoke goggles donned, it was difficult to find the switch to clear the goggles of smoke (see figures 9 and 10) and one stated “it was “awkward”.



Figure 101: Smoke vent valve selector (closed)      Figure 102: Smoke vent valve selector (open)

The pilots did not believe they would have thought to clear the goggles if they had not practiced it before the scenario. Pilot #1 stated that it was a misconception that the goggles should fit snugly. He said they were designed to be loose so that the goggles could be cleared of smoke. The instructor informed the crew that they should have completed the smoke fire and fumes checklist prior to completing the smoke removal checklist. Asked who would be in charge of communicating with ATC, both pilots indicated that the PM would do this.

If this was a single pilot operation, pilot #2 stated that the situation would have been “mind boggling” and he would have foregone the checklist. He also believed it would have been difficult to fly the approach without being able to see the instruments and having specific headings and altitudes. Pilot #1 said it would have been very difficult and that one person needed to be dedicated to remove the smoke. He indicated that he would have considered a controlled crash in the water if he was in a situation where he could not see his instruments.

Pilot #2 indicated that with the smoke goggles donned, he could not see the standby compass. He said the image was distorted and he would have gotten his flashlight to improve visibility of the compass. Figures 11 and 12 show how close a pilot could get to the instrument panel with the oxygen mask and goggles donned.



Figure 103: Closest position to the MCP



Figure 104: Closest position to the FMS

Pilot #1 stated that not having a live mic could be an issue. He said if he did not hit the lower rocker (the “push to talk” switch on the audio panel; see figure 13), pilot #2 could not hear him. It was difficult to do this when holding the checklist.



Figure 105: “Push to Talk” switch

One person indicated that the Boeing 747 manual states to consider landing anywhere. One person also stated that pilot suggestions and recommendations for changes usually go into the “trash can”.

The instructor who participated stated that he believed the smoke fire and fumes checklist to be the most complicated checklist and the scenario presented would have been a lot for any crew to do. He

said the checklist had been redefined since flight safety. He stated that the crew donned the mask during initial training but it was not a scenario in subsequent training.

The pilots in the exercise did not know about preflight maintenance of O2. Regarding the different oxygen levels of the oxygen mask (see figure 10), “Normal” was a mix of ambient air and oxygen and the higher you get, the more O2 that was introduced, “100%” was 100% oxygen and “emergency” was positive pressure and 100% oxygen.



Figure 106: 100% Selector Switch on Oxygen Mask

In addition, investigators noted that the instructor did not use a headset during the scenarios.

Scenario #1b: Understanding Pack Logic.

Summary of observations

When the main deck’s cargo fire arm switch was armed, packs 2 and 3 were shut off. If pack 1 was turned off, pack 3 came back on as long as the pack 3 switch was still in the “norm” position. Page 8-10 of the smoke, fire, or fumes checklist stated to turn the pack 2 and 3 selectors to off. If this was completed and pack 1 failed without the crew recognizing this, pack 3 would not come back on. If the pilot turned pack 3 selector back to “norm”, the system logic was reset and pack 3 would turn back on. The system logic did not reset when the pack 2 selector was turned back to “norm”. The instructor stated that pack 2 did not have a dump valve; only packs 1 and 3 had a dump valve.

Scenario #1c: Donning Oxygen Mask and Goggles While Wearing a Headset.

Summary of observations

It took approximately 28 seconds for the crew to don both the oxygen mask and smoke goggles. It took an additional 6 seconds for the crew to establish crew communications. The scenario was run two times and both times the headset was knocked off when donning the oxygen mask (see figure 15).



Figure 107: Headset location after donning mask

Pilot #2 also indicated that to don the oxygen mask with the headset on, the pilot would have to move the boom of the headset to get the right seal on the mask. With the mask on, the crew could communicate using the rocker switch on the audio panel or on the control yoke.

Simulator Session #2 set up:

Altitude: FL320

Location: 140 NM from Hong Kong

Heading: 180 degrees away from Hong Kong

Weather: clear skies, unlimited visibility, winds calm, night

PF: first officer/pilot #1; PM: captain/pilot #3

Scenario #2a: FIRE MN DK FWD warning and heavy smoke introduced to the cockpit such that instruments cannot be seen. About 10 minutes into the scenario, the crew will be informed that smoke and fire severe and immediate landing must be performed.

Summary of observations

The flight crew received the fire main deck forward warning about 40 seconds into the scenario. Pilot #3 called for the fire main deck checklist about 1:35. At 1:50, smoke was reported to the crew. Oxygen masks were donned by both crewmembers by 2:03 and communication checks were completed by 2:20. At 2:40, pilot #3 indicated that the checklist would be started and then declared an emergency with ATC at 2:50. ATC gave the crew a right turn to heading 240. At 3:29, the fire main deck checklist was started. Pilot #3 had a difficult time finding some of the switches. Pilot #3 turned the pack switches to off however there was no EICAS (Engine Instrument and Crew Alerting System) message to indicate they were off and the switches should be moved. At 5:24, the smoke became so severe that the pilots could no longer see their instruments. At 7:21, pilot #3 requested that ATC keep the flight over water. Pilot #3 called for the smoke, fire or fumes checklist at 8:28. He stopped the checklist and asked that ATC call out his altitude in 1000' increments. ATC cleared the flight to FL100. ATC gave the flight a descent to 4000 feet. Pilot #3 adjusted the altitude window. Pilot #3 resumed the checklist at 10:10. The smoke removal checklist was started at 13:00 due to pilot #3 distractions with ATC communications. ATC delayed communications due to simulation that airplane was out of frequency range. At 14:30, the crew decided to ditch the airplane. The smoke removal checklist was interrupted numerous times because of ATC

communications, including frequency changes, and altitude and heading clearances. The PM/PF duties seemed to go back and forth. The flight crew prepared for a ditching.

#### Summary of debrief

Pilot #3 stated that the smoke, fire or fumes checklist had lots of branches and was long. He said using the goggles and mask made it more difficult. He said it was tough to plan it out and rely on ATC for headings and altitudes; he did not know where he was. He said it was the worst of all situations to have no heading and altitude. Pilot #3 believed about 20 minutes had passed when completing the scenario. Pilot #3 indicated it was frustrating when ATC would not respond to his requests because he needed the information now.

During the continuation of the Smoke, Fire or Fumes checklist, Pilot #3 did not wait the 2 minutes required between the selection of Pack 2 off and Pack 3 off.

The pilots indicated that the PM normally changed the altitude in the window.

Pilot #3 said if smoke was severe he would turn off the packs and pull the smoke handle to see if it would get better. The pilots stated that if the smoke handle was pulled open, it could be closed again.

Pilot #3 did not notice whether the pack 1 went offline during the scenario.

Both pilots indicated that they thought they were much closer to Hong Kong than they were. The instructor stated that they were about 140 miles from Hong Kong when the scenario started but they flew farther away as they were making their turn.

Pilot #3 received his initial training on the B747-400 about 2 years ago.

If there was no first officer available, pilot #3 thought he would get down low and probably stop performing the checklist. He said with pilot #1 flying the airplane, he lost track of time. He said it took time to get to each checklist.

Pilot #3 said his peripheral vision was limited with the goggles on and he had to look right at the switch.

Scenario #2b: run through the smoke, fire or fumes checklist to completion.

#### Summary of observations

The crew received a main deck fire mid warning. Pilot #3 was the PM and pilot #1 was the PF. At time 0:35, pilot #3 declared an emergency with ATC. At time 1:20, pilot #3 called for the main deck fire mid checklist. At time 2:00, the checklist had not been started. The fire main deck checklist was completed at 4:30. At time 4:40, pilot #3 called for the smoke, fire or fumes checklist. There was no challenge/response when checklist was run. At time 10:10, pilot #3 began the smoke removal checklist. At time 11:22, pilot #3 pulled the smoke handle. After the handle was already pulled, pilot #3 said "unless you have a better idea". PF stopped the PM from reading the checklist to set 5000 feet in the altitude window. The smoke, fire and fumes checklist was completed at 14:24.

#### Summary of debrief

Pilot #3 said that with the smoke goggles on, he really wanted to make sure that he was moving the right switch and he would take time to confirm the right switch.



**GCAA Air Accident Investigation  
EVAS Working Group**

**From:** Air Accident Investigation Sector, GCAA

**To:** EVAS Working Group

**Date:** 10/03/2011

**Subject:** EVAS Working Group

Summary:

Based on historical accident investigation recommendations following Smoke, Fire or Fumes (SFF) in the flight deck, former working group reports published by other regulatory authorities and recent accident investigation findings, an EVAS working group has been established to review the current industry and regulatory understanding of the primary safety issues surrounding SFF flight deck environments.

Background:

The GCAA, in conjunction with the NTSB, recently performed a simulator SFF exercise to develop an empirical set of working criteria to understand the operations, crew performance and crew functioning processes associated with SFF in the flight crew operating environment; in conjunction with a follow up of the recommendations of the Smoke/Fire/Fumes Industry Initiative of 2006.

Objectives:

The intention with the EVAS Working Group is to use the current information available to fully understand the practical limitations of flight deck SFF, the current operating practices, non normal checklist function; this is to provide a baseline for further investigation/analysis.

Using the facilities available with the operators, i.e. Simulators or other Ground Based Training Device (GBTD), perform and document an objective analysis of crew response, functioning and performance in SFF, flight deck visually degraded conditions.

Based on the test results, formulate a risk assessment standard and produce an industry-regulator agreed recommendation stand alone document which clearly defines the requirements for an SFF review and the pros and cons of the EVAS system.

This recommendation stand alone document should demonstrate the:

- Current risks with SFF procedures,
- The Airbus/Boeing recommended practices – shortfalls/suggested improvements
- Current airline operating standards for non-normal checklists,
- The pros and cons of the EVAS system,
- The use of possible alternative checklist formats



- Provide a benchmark document specific to the UAE which can be used as justification for possible inclusion or exclusion of the EVAS system based on known empirically verified data and assumptions.

The conclusions from the testing/demo should be in two phases and include the following:

1. Validation of the EVAS system as an independent method for managing a SFF situation from an airborne phase to getting on the ground, and/or ditching
2. CRM processes using EVAS in Smoke/Fire/Fumes situations

Suggested evaluation outline:

3. Analyse current crew Standard Operating Procedures (SOP) during SFF events.
4. To analyse the how crew performance is affected during SFF events with current procedures
5. Validate the EVAS system
6. Based on recent SFF initiatives, propose modified methodology
7. Observations/comments on
  - 7.7 The EVAS system
  - 7.8 Training requirements

Primary Framework for Review and Analysis

- Donning masks
- Verification and checking of the oxygen selector switch position
- Establishing communication
  - PF to PNF
  - A/C to ground
- Ability to perform designated functions in a Smoke, Fire, Fumes (SFF) environment with mask on.
- Activation and installation of EVAS system
- Use of the circular EVAS viewing portal as an alternative viewing system
- PF v PNF communications during an emergency EVAS installed
- Running non normal checklists in a SFF flight deck
- Ability to manipulate the Flight Management/Guidance Unit(FMGU) operation, Flight Control Unit (FCU), radio freq selection in a smoke filled flight deck
- General aircraft handling - PF
- PF v PNF Role and Function
- 2 EVAS units extended verse 1 Unit extended? Advantages/Disadvantages
- Cockpit Resource Management (CRM)
- Observations on the benefit of the EVAS system
- Observations on the disadvantages of the EVAS system
- Proposed modifications to the EVAS system?
- Overall opinion based on the 2 demo' scenarios

Tasks:

Based on the two scenario demonstrations in the A330 simulator:

- i. APP to AUH/ Low level/Outer marker
- ii. FL200/Emirates FIR/Emergency Decent/Radio Change/Flight Management System.

Analyse the testing within the framework provided above, with any additional relevant information and provide feedback for a draft EVAS Working Group summary evaluation.

### **Working Group Comments/Observations:**

- a) As we move to a paperless environment, how will crews cope with the EVAS and EFBs as they usually are located away from the normal area of observation?
- b) We saw during the trial that the flexibility of the unit can cause changes to the aircraft status when pushed against certain locations (loss of Auto Thrust). Can we prevent this?
- c) What sort of SOP and Checklist changes will be required and how much resistance will come from the OEMs? This can be a big issue for those operators who strictly follow manufacturer guidance.
- d) What is the minimum acceptable training that will be accepted by the regulators? And what sort of format will be required (paper, CBT, Sim, etc.)? If there are sim requirements for training, will multiple scenarios be required or will one attempt be sufficient?
- e) If an airline has mixed fleets of Cargo and Passenger aircraft and regulators move towards requirements for EVAS installation on only one fleet (i.e. Cargo only) how does this make the operator liable should a SFF situation occur on the non-equipped fleet?
- f) CRM and HF issues need to be examined as was discussed, and documented so appropriate training can be developed if required.
- g) Some sort of device for viewing the overhead panel will definitely be required as we saw in the sim demo.
- h) How will the system operate with head up displays (HUDS)?

**NATIONAL TRANSPORTATION SAFETY BOARD**

Vehicle Recorder Division  
Washington, D.C. 20594

July 24, 2013

# **Cockpit Voice Recorder – Sound Spectrum Analysis Study Report**

**Specialist's Study Report  
By Doug Brazy**

## 1. EVENT SUMMARY

Location: Dubai, United Arab Emirates  
Date: September 3, 2010  
Aircraft: Boeing B747-400F  
Registration: N571UP  
Operator: United Parcel Service  
NTSB Number: DCA10RA092

At about 7:45 pm local time (1545 UTC), United Parcel Service (UPS) Flight 6, a Boeing 747-400F (N571UP), crashed while attempting to land at Dubai International Airport (DXB), Dubai, United Arab Emirates (UAE). Approximately 45 minutes after takeoff, the crew declared an emergency due to smoke in the cockpit and requested a return to DXB. The two flight crew members were fatally injured. The airplane was being operated as a scheduled cargo flight from Dubai, UAE to Cologne, Germany.

The Cockpit Voice Recorder (CVR) Group for this investigation noted that both crewmembers had some unidentified issues with the crew oxygen system. Both crew had donned their oxygen masks approximately 1.5 minutes after the firebell sounded. About 5.5 minutes later, the Captain indicated that he was out of oxygen, and his breathing sounds (as captured by the oxygen mask microphone) ceased. About 2 minutes later, the First Officer's breathing sounds stopped for about 20 seconds. About 20 seconds later the First Officer said "I'm looking for some oxygen" during a radio transmission. Shortly thereafter, his breathing sounds stopped again for about 20 seconds. After this, his breathing sounds can be heard until the end of the recording (about 20 minutes later). However, about 10 minutes before the end of the recording, the First Officer transmitted "...we are running out of oxygen."

In order to better understand how the oxygen system was being used (i.e. the mask configuration of "normal" vs. "100%", the "Emergency" setting, and the smoke vent setting), a flight test was conducted using oxygen masks of the same make/model as was installed on N571UP. The masks were operated in flight and on the ground, using all possible configuration settings. During these tests, the audio from the mask microphones and the cockpit area microphone was captured by the airplane's CVR, and used for comparison with the audio from the accident flight.

The results of this study indicate that the sound spectrum data from the accident flight is most consistent with the following:

- Captain's mask setting: 100 %
- First Officer's mask setting: Normal
- Neither mask appears to be in the "emergency" mode
- The smoke vent condition (open or closed) could not be determined for either mask

## 2. SOUND SPECTRUM GROUP

A group was not convened.

## 3. DETAILS OF INVESTIGATION

### 3.1 Items Received

On November 19, 2010, the Safety Board's Vehicle Recorder Division received the following:

Manufacturer/Model: Fairchild Model FA2100-1020 Cockpit Voice Recorder Serial  
Number: 000540625

This CVR was installed in the flight test airplane (a United Parcel Service Boeing B747-400 BCF) and was the same model as the unit installed in N751UP.

### 3.2 Background Information

Testing of an exemplar oxygen mask<sup>9</sup> in the NTSB laboratory revealed that the sound of air moving through the mask (i.e. "breath sounds") are distinctly different when the mask is used in different "modes". The "Normal" mode provides the user with a mixture of ambient air and oxygen, at a ratio that varies with ambient pressure. The 100% mode provides the user with 100% oxygen. When listening with the 'naked ear', the inspiratory noise (inhale) from the oxygen regulator is noticeably different when using one mode versus the other. Generally, the 100% mode has a slightly higher pitched sound than the Normal mode. The difference is readily detectable when listening to the mask in operation switching back and forth between modes. It is difficult to identify the mask mode when listening to either mode in isolation.

The sound during the expiratory phase (exhaling) is about the same in either mode.

Additionally, the mask has an "Emergency" setting which can be enabled in either the Normal or 100% mode. This setting continually pressurizes the mask with oxygen. When the Emergency setting is on, a characteristic "chattering" sound is occasionally present between breaths. This characteristic does not occur continually, but it did occur at least once in all tests when the Emergency setting was activated.

The smoke vent is used in conjunction with the Emergency setting. With the Emergency setting "on", the mask cavity is continually pressurized with oxygen. Opening the smoke vent exposes a small hole near the top of the mask cavity, at the nose bridge. This allows oxygen to flow upward and out of the mask cavity, to clear or defog smoke goggles if they are worn. If the Emergency setting is "off", no oxygen will flow through the smoke vent.

### 3.3 Flight Test Recording Examination

---

<sup>9</sup> The exemplar mask was the same make and model as the masks installed on the accident airplane (Intertechnique model MC-10-25-104).

The CVR recording system used during the test flight was identical to the accident airplane. The CVR captures audio from the Cockpit Area Microphone (CAM) as well as from each pilot's microphone. Normally, pilots' headset boom microphones are recorded on the CVR. However when oxygen masks are used, a separate microphone inside the mask (used by the pilots to communicate) is recorded instead of the headset microphone. In this installation, the switching from the headset to the oxygen mask microphone occurs via a pneumatic switch in the mask stowage box. When the mask is pressurized for use, the microphone inside the mask becomes active and the headset boom microphone is deactivated.

### 3.4 Auditory Review

During the tests, while the airplane was on the ground without the engines running, the audio from the CAM yielded results similar to the testing in the NTSB lab. Differences in the inspiratory noise breath could be heard when comparing one mask mode to the other. However while in flight, these differences were much more difficult to discern.

The audio from the oxygen mask microphone sounds significantly different than the CAM audio. This is not unexpected, because the CAM is mounted in the overhead panel inside the cockpit, and captures the mask noise from "outside" of the oxygen mask. The mask microphone is located inside the mask cavity, on the opposite side of the mask regulator from the CAM. In other words, it is not unexpected that the breathing noises would actually sound different on the inside of the mask vs. the outside. Additionally, the mask microphones audio has a different frequency response than the CAM. When listening to the audio from the mask microphones, the inspiratory noises from both the Normal and 100% modes sound very similar to one another.

### 3.5 Sound Spectrum Analysis Review

The audio from the flight test was also examined using a software frequency analysis program. Spectrogram charts (three dimensional presentations of time, frequency and energy) of the audio were generated for each of the test segments<sup>10</sup>, and these charts were reviewed for any signatures that were unique to specific settings of the oxygen masks.

### 3.6 Cockpit Area Microphone Audio

Figure 107 shows a spectrogram of Test Points 1 ("TP1", Normal mode) and Test Point 3 ("TP3", 100% mode) while on the ground with the engines off. The spectrogram depicts elapsed time on the bottom horizontal axis, frequency on the left vertical axis, and uses color to represent relative intensity or energy of the audio signal. Darker blue colors represent lower energy, brighter red and yellow represent higher energy.<sup>11</sup>

---

<sup>10</sup> Additional information including the flight test plan can be found in the attachment - "Flight Test Results for UPS B747 Flight 6 Accident, Oxygen System Data Collection".

<sup>11</sup> Some charts in this report may also contain white (off scale – low) or cyan (off scale – high) colors.

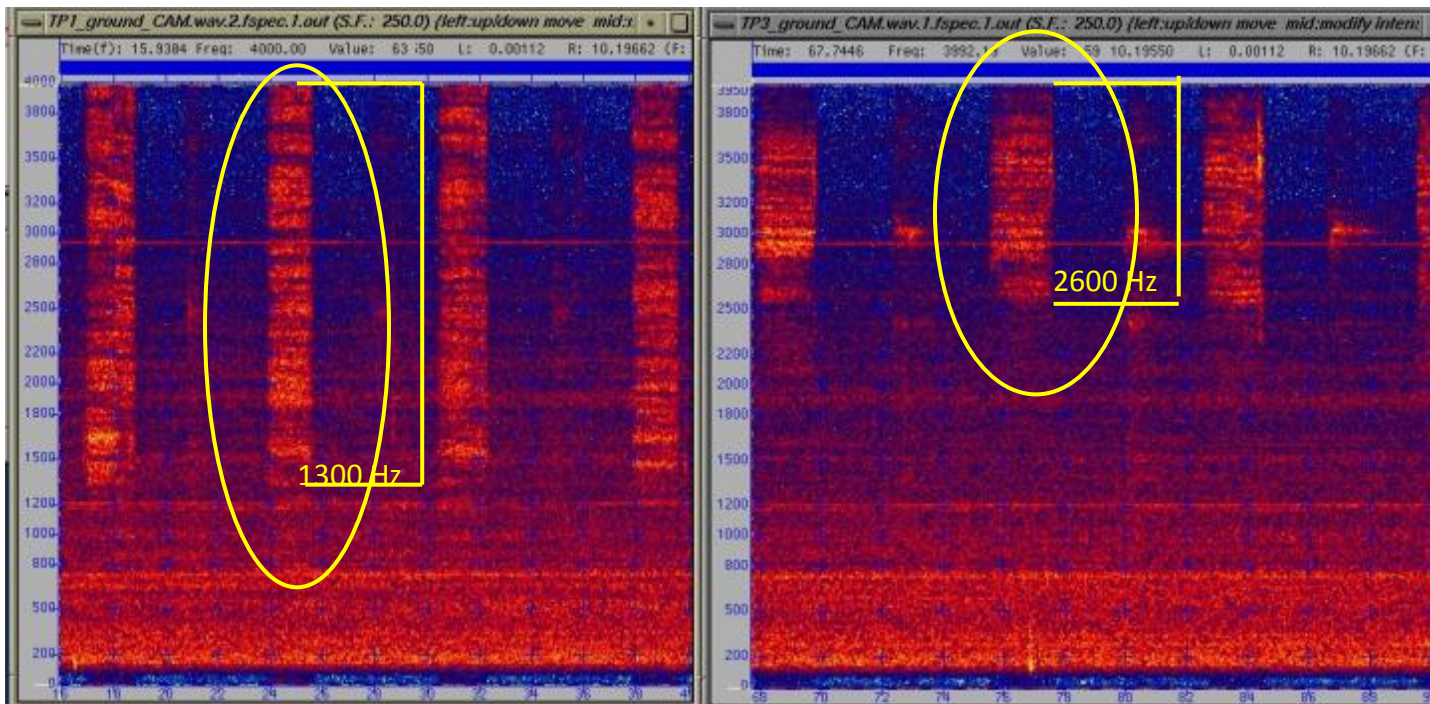

Figure 108 – Spectrogram of CAM - Test points 1 and 3, on Ground

The left side of Figure 107 shows the sounds during TP1 (mask in Normal mode). One of the inspiratory noises is circled in yellow. This chart shows a relatively equal distribution of sound energy over a range from about 1300 Hz to 4000 Hz. In contrast, the right side of Figure 107 shows the audio from TP3 (100%) mode, where the majority of energy is spread over a range from about 2600 Hz to 4000Hz. This is consistent with the auditory review of the recording which indicated that 100% mode sounded as though it had a higher pitch. This spectrogram shows that the 100% mode actually has less sound energy in the lower frequency range, which causes it to sound as though it has higher pitch when compared to the Normal Mode.

In flight, this characteristic is much more difficult to discern, due to the background ambient noise in the cockpit. The area highlighted in Figure 108 shows the background noise during flight is too loud to see the lower frequency range of the inspiratory noise. As a result, this characteristic was not suitable to differentiate between mask modes.

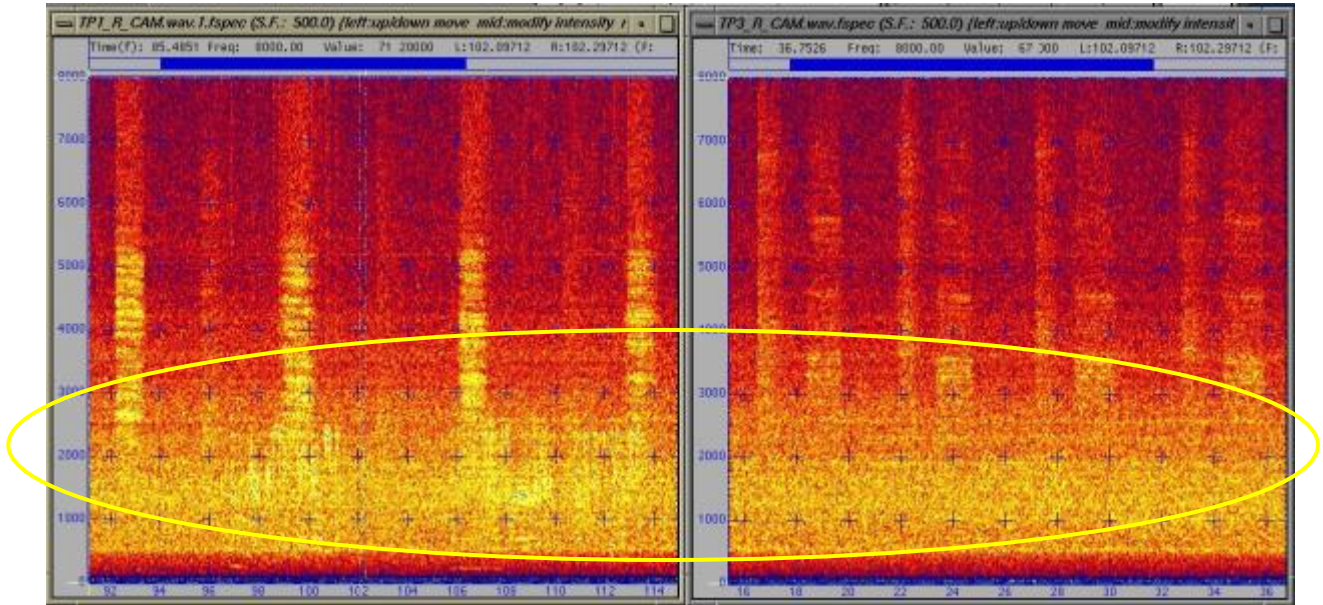

Figure 109 - Spectrogram of CAM - Test points 1 and 3, During Flight

#### Oxygen Mask Microphone Audio

The auditory review of the mask microphone audio revealed that the breath noises did not sound significantly different between the two mask modes. However, the sound spectrum analysis found a unique characteristic in the audio that differentiates one mask mode from the other. Figure 109 shows a spectrogram of the inspiratory noise from a single breath, as recorded from the oxygen mask microphone.

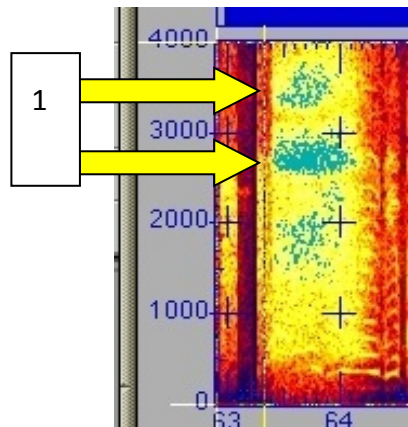

Figure 110 – Spectrogram of Inspiratory Noise from Mask Microphone Audio

The audio from the mask microphones exhibits characteristic “bands” of energy during inspiratory breaths (light blue regions labeled 1 and 2 in Figure 109). These bands are a concentration of relatively higher sound energy within certain frequency ranges. The height of the bands (range of frequency) and total number of bands seems to vary, and may be affected by the overall loudness of the breath sound itself. However, two of these bands are present in all segments of audio that were examined (labeled 1 and 2 in Figure 109). The unique characteristic is the “center” frequency of Band 2. The band height (total frequency range) can vary, but the center of the band appears to be unique to the mask mode. In

all test cases the center of band 2 was higher (by about 140 Hz) when the mask was in normal mode, than when in the 100% mode.

**Error! Reference source not found.** shows several spectrograms of mask microphone audio. The top section shows the audio from the accident flight (UPS 006). The left side is the First Officer's channel, the right side is the Captain's channel. The subsequent sections show the audio from the flight test, where yellow boxes outline the sound when the mask is in Normal mode; red boxes outline the sound when the mask is in 100% mode. This figure depicts the variance in the number and height of the frequency bands.

The spectrograms in **Error! Reference source not found.** are identical to those in **Error! Reference source not found.**. In **Error! Reference source not found.**, the centerline of band 2 for the Normal mode is annotated with a black horizontal line (centerline frequency approximately 2700 Hz). The red arrows show that for the 100% mode, the band 2 centerline is always lower (below the black line) than it is for the Normal mode. The centerline for band 2 in 100% mode is approximately 2560Hz.

The audio from the accident airplane is at the top of **Error! Reference source not found.**. The left hand side shows the audio from the First Officer's mask microphone, with the center of band 2 at approximately 2700 Hz which is consistent with the Normal mode. The right side shows the audio from the Captain's mask microphone, with the center of band 2 at about 2560 Hz, consistent with the 100% mode.



Figure 4

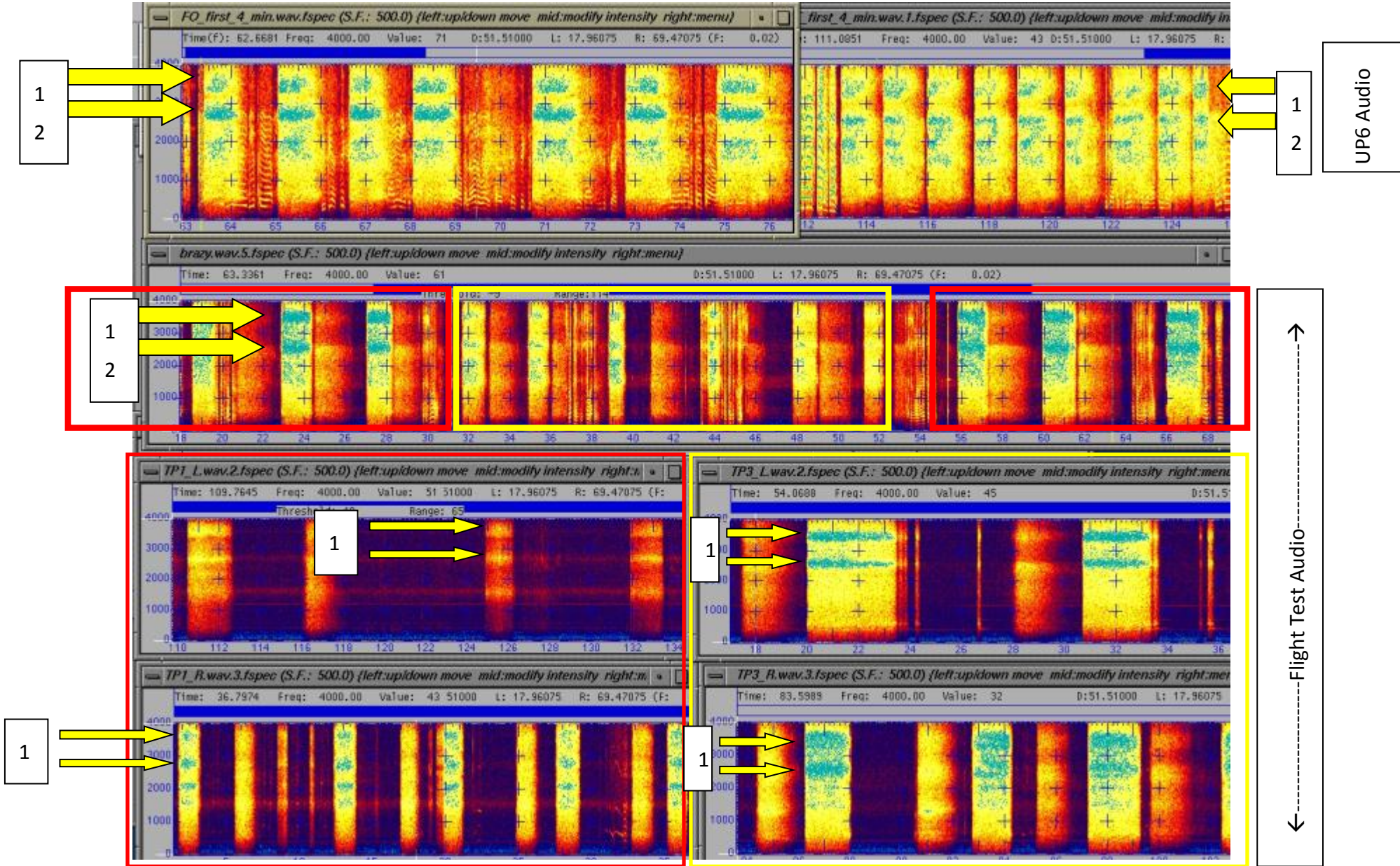
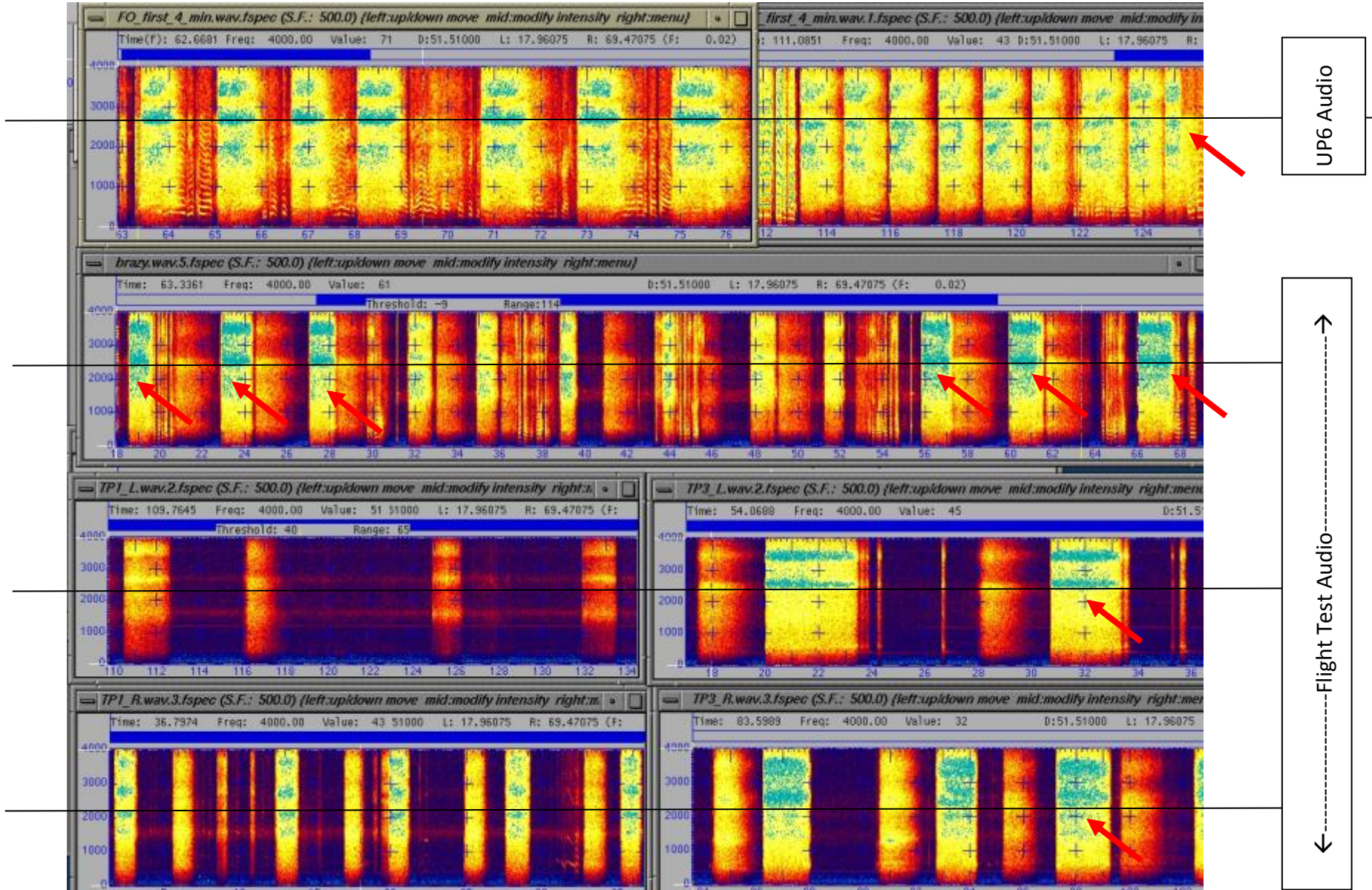

Figure 5



UP6 Audio

Flight Test Audio

This “frequency shift” of the centerline of band 2 according to mask mode is consistent throughout all of the audio from the test flight, which varied among 3 separate masks and 4 separate pilots, both in flight and on the ground.

In the accident recording, the centerline frequency of band 2 for the First Officer’s audio is consistent with the flight test data for the Normal mask mode, throughout the recording. Segments of audio were examined at the time the mask was donned, at time the cabin altitude reached its peak (approximately 25,000 feet)<sup>133</sup>, and at the end of the recording. The Captain’s audio was consistent with flight test data for the 100% mask mode at the time the mask was donned, at the time of the last breath sounds and at several other randomly selected times in between.

### 3.7 Emergency Setting

During the testing in the NTSB laboratory as well as the flight test, a characteristic was noted which appears to be consistent with the emergency setting set to “on”. This characteristic can be heard audibly as well as seen in a spectrogram. It is a “chattering sound” that occurs between breaths. This characteristic is not continuous and only occurs occasionally, however it occurred at some point during every test when the emergency setting was on, and did not occur in any tests when the setting was off. None of the audio on the accident recording contained this characteristic. The “chattering” is visible as the series of thin dark vertical lines highlighted in Figure 110.

---

<sup>133</sup> The oxygen mask in Normal mode will automatically vary the ratio of oxygen to ambient air as a function of cabin altitude. According to the manufacturer, the mask will provide 100% oxygen at a cabin altitude of 30,000 feet. In this condition, the mask operates in the same manner as if it were in the 100% mode, and should sound the same as 100% mode. Data from the Flight Data Recorder indicated that the cabin altitude reached a peak of about 25,000 at 19:17:20 Local time.

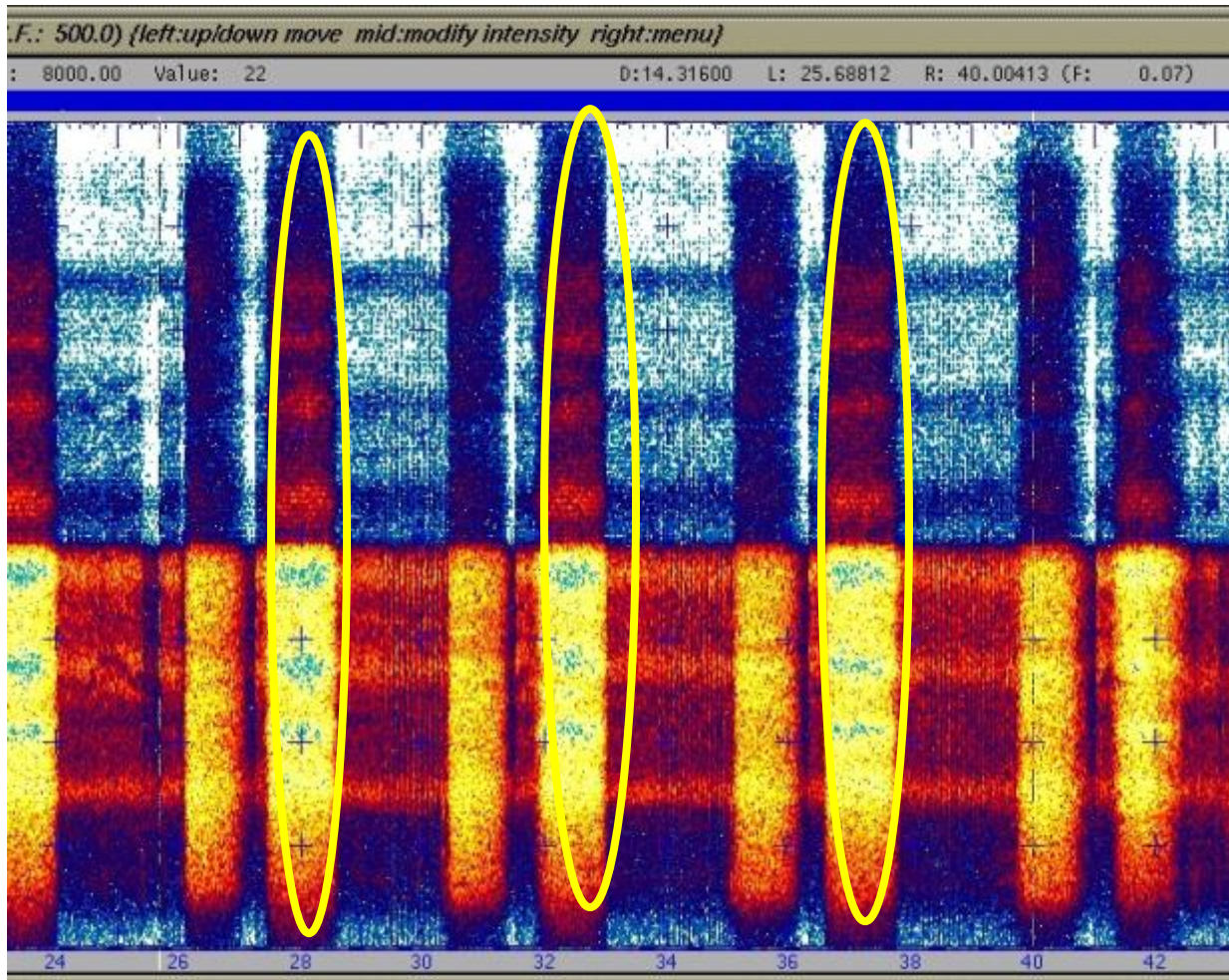

Figure 111 - Emergency Setting = On

### 3.8 Smoke Vent Setting

A cursory review of the spectral data from the flight test for the opening or closing of the smoke vent did not reveal any unique characteristics associated with a setting of open or closed.

Doug Brazy  
Mechanical Engineer/CVR  
NTSB Vehicle Recorder Division

## Flight Test Results for UPS B747 Flight 6 Accident, Oxygen System Data Collection

(NTSB # DCA10RA092)

**Aircraft:** Boeing 747-400 (BCF<sup>134</sup>), N579UP, Flight 9902  
**Airport:** SDF  
**Participants:**

### **Flight Test #1 - Tasks 1 and 2:**

NTSB: Katherine Wilson (Operations/Human Performance Group)  
David Lawrence (Operations/Human Performance Group)  
Doug Brazy (CVR Group)  
UPS: Captain Doug Menish  
Captain John Fanning<sup>135</sup>

**Date/departure Time:** November 17, 2010/1252 est

### **Objectives:**

8. To document, in flight, the audio/sound differences when positioning the oxygen mask system to various settings (normal, 100%, emergency) with and without the smoke goggles vent on.
9. To document, on ground, the donning and accessibility of emergency equipment within the cockpit to flight crew members.

### **Overview:**

The group chairmen of the Operational Factors/Human Performance Group and CVR Group participated in an observational study. The airplane used for the observations was a UPS Boeing 747-400, a BCF, N579UP, operating as flight 9902 heavy.

The purpose of the test flight was to document the audio/sound differences on the flight deck when crewmembers have donned oxygen masks and smoke goggles to be used as a comparison to the audio/sounds from the UPS 6 flight. In addition, the accessibility of emergency equipment available in the cockpit was documented.

The pilots and observers were fully briefed on each task and scenario before it was attempted.

During the test flight, the observers captured data via hand written notes, and audio and video recording. At the completion of the flight, the pilots flying provided comments on ease of completing the procedure and other observations made.

---

<sup>134</sup> Boeing converted freighter

<sup>135</sup> Capt. Fanning was a captain on the B-747-400 and former APD. He was type rated on the B-747-400, B-727, B-757, and B-767, and was a flight engineer on the L-382. He had about 10,000 hours total time and 9,000 hours as pilot in command.

**Takeoff – KSDF****Task 1****Initial Setup**

- Weight - Normal Takeoff, Normal Thrust Setting
- CG - OPTIONAL
- Config - Standard

		Flaps/Gear	
Risk	Cond.	Flaps	Operation
		10	Perform normal flaps 10 takeoff

**Climb to FL320****Initial Setup**

- Weight - Normal Climb to FL320
- Thrust - Normal Climb
- Config - Standard
- Pressurization - Auto

**Procedure**

- 3) Set Power for normal climb to FL320
- 4) Maintain normal climb airspeed
- 5) Perform standard fuel burn
- 6) Set Standard cabin pressurization
- 7) Identify Pilot Flying (PF) and Pilot Monitoring (PM) prior to initiation of O2 tests.

		Flaps/Gear	
Risk	Cond.	Flaps	Operation
		Standard	Perform normal climb to FL320

**General Setup For Cruise****Initial Setup**

- Weight - Normal
- Thrust - Standard Cruise
- Config - Standard
- Pressurization - Auto

**Procedure**

- 8) Set Power for normal cruise at FL320
- 9) Maintain normal climb airspeed
- 10) Perform standard fuel burn
- 11) Set Standard cabin pressurization
- 12) Identify Pilot Flying (PF) and Pilot Monitoring (PM) prior to initiation of O2 tests.

		Flaps/Gear	
Risk	Cond.	Flaps	Operation
		Clean	Establish normal cruise at FL320

### **General Notes**

**Task 1: Position the oxygen mask system to various settings (normal, 100%, emergency) with and without the goggles vent open during flight**

- The aircraft door was closed at 1148 and the flight departed at 1253.
- All crew mics were operational. The left jumpseat O2 mask hot mic was inoperative but the intercom worked.
- All scenarios were run at a cruise flight altitude of FL320 and a normal cabin altitude of 4400 feet.
- Prior to each scenario, the observer briefed the participating pilot(s) prior to execution (e.g., “Captain performing scenario 1b, mask normal, vent open, goggles on.”).
- For scenarios 1-4, only one pilot participated in the scenario while the other pilot performed the duties of the pilot flying (PF). Only the participating pilot, who was also performing the duties of pilot monitoring (PM), donned the oxygen mask and smoke goggles during scenarios 1-4. For scenarios 1-4, the PM was asked to breathe 5 times (to inhale, hold his breath for 2 seconds and then exhale), followed by 20 seconds of normal breathing. After the completion of scenarios 1-4 by the PM, the pilots switched roles and the PF, now acting as the PM, completed scenarios 1-4. The pilot in the right seat participated in scenarios 1-4 first, followed by the pilot in the left seat.
- For scenario 5, both pilots donned oxygen masks and were asked to breathe normally for 1 minute.
- For scenarios 6-8, the PM was asked to hold the oxygen mask slightly away from his face and to breathe normally for 1 minute. Scenarios 6-8 were performed by the pilot in the left seat.
- Scenarios 9-11 were performed by the pilot in the left seat with the oxygen mask in his lap. For scenario 9, an observer spoke from the rear of the cockpit for 1 minute. For scenario 10, the mask was set to emergency for 5 seconds. For scenario 11, the smoke evacuation vent was open for 10 seconds.
- When the smoke handle was pulled in flight, the cabin altitude was 4400 feet, and the cabin climbed +100 fpm for a brief time before settling at zero climb (no noticeable differential change).
- The flight landed at 1414.
- On shutdown, the crew received a “Crew O2 Low” EICAS message.

### **Equipment Used**

The CVR, FDR and oxygen masks used for Task 1 were identical to those of the accident airplane.

### Task 1: Oxygen Mask/Smoke Goggles Test

Task / Seat	O2 Mask Position: PM	Smoke Vent: PM	Goggles: PM	O2 Mask Position: PF	Smoke Vent: PF	Goggles: PF	PM Actions	Start Time	Stop Time	Comments
1a-R	Normal	Closed	On	N/A	N/A	OFF	5 breaths, 2 secs apart; then 20 secs, normal breathing	13xx	13xx	
1b-R	Normal	Open	On	N/A	N/A	OFF	5 breaths, 2 secs apart; then 20 secs, normal breathing	13xx	13xx	Pilot had difficulty finding smoke vent with mask and goggles on.
2a-R	Normal/ Emerg <sup>136</sup>	Closed	On	N/A	N/A	OFF	5 breaths, 2 secs apart; then 20 secs, normal breathing	1318	1319	NOTE: MY CLOCK WAS 1 MINUTE AHEAD OF CAPTAIN'S CLOCK
2b-R	Normal/ Emerg	Open	On	N/A	N/A	OFF	5 breaths, 2 secs apart; then 20 secs, normal breathing	1319	1320	
3a-R	100%	Closed	On	N/A	N/A	OFF	5 breaths, 2 secs apart; then 20 secs, normal breathing	1321	1322	
3b-R	100%	Open	On	N/A	N/A	OFF	5 breaths, 2 secs apart; then 20 secs, normal breathing	1322	1323	
4a-R	100%/ Emerg <sup>137</sup>	Closed	On	N/A	N/A	OFF	5 breaths, 2 secs apart; then 20 secs, normal	1323	1324	

<sup>136</sup> Mask position set to normal, emergency on

<sup>137</sup> Mask position set to 100%, emergency on



Task / Seat	O2 Mask Position: PM	Smoke Vent: PM	Goggles: PM	O2 Mask Position: PF	Smoke Vent: PF	Goggles: PF	PM Actions	Start Time	Stop Time	Comments
							breathing			
4b-R	100%/ Emerg	Open	On	N/A	N/A	OFF	5 breaths, 2 secs apart; then 20 secs, normal breathing	1324	1325	
<b>Pilots switched PM/PF roles</b>										
1a-L	Normal	Closed	On	N/A	N/A	OFF	5 breaths, 2 secs apart; then 20 secs, normal breathing	1328	1329	
1b-L	Normal	Open	On	N/A	N/A	OFF	5 breaths, 2 secs apart; then 20 secs, normal breathing	1329	1330	Pilot had difficulty finding smoke vent with mask and goggles on.
2a-L	Normal/ Emerg	Closed	On	N/A	N/A	OFF	5 breaths, 2 secs apart; then 20 secs, normal breathing	1330	1331	
2b-L	Normal/ Emerg	Open	On	N/A	N/A	OFF	5 breaths, 2 secs apart; then 20 secs, normal breathing	1331	1333	Pilot had difficulty finding smoke vent with mask and goggles on.
3a-L	100%	Closed	On	N/A	N/A	OFF	5 breaths, 2 secs apart; then 20 secs, normal breathing	1333	1334	Pilot had difficulty finding switch to change mask from Normal to 100%.
3b-L	100%	Open	On	N/A	N/A	OFF	5 breaths, 2 secs apart; then 20 secs, normal breathing	1334	1335	Pilot had difficulty finding smoke vent with mask and goggles on.
4a-L	100%/ Emerg	Closed	On	N/A	N/A	OFF	5 breaths, 2 secs apart; then 20	1336	1337	Pilot had difficulty finding knob to turn on emergency oxygen.

Task / Seat	O2 Mask Position: PM	Smoke Vent: PM	Goggles: PM	O2 Mask Position: PF	Smoke Vent: PF	Goggles: PF	PM Actions	Start Time	Stop Time	Comments
							secs, normal breathing			
4b-L	100%/ Emerg	Open	On	N/A	N/A	OFF	5 breaths, 2 secs apart; then 20 secs, normal breathing	1337	1338	Pilot had difficulty finding smoke vent with mask and goggles on.
<b>Both pilots donned mask and goggles; established crew comms via toggle switch between seats.</b>										
5-L/R	Normal	Close d	Off	100%	Close d	OFF	1 minute, normal breathing	1340	1341	Crew received an ATC call; F/O answered call using yoke toggle switch.
<b>Remaining scenarios performed by pilot in left seat</b>										
6-L	Normal, canted to side	Close d	Off	N/A	N/A	OFF	1 minute, normal breathing	1341	1343	Pilot held mask slightly away from face.
7-L	100%, canted to side	Close d	Off	N/A	N/A	OFF	1 minute, normal breathing	1343	1344	Pilot held mask slightly away from face.
8-L	Normal, canted to side	Open	Off	N/A	N/A	Off	1 minute, normal breathing	1344	1345	Pilot held mask slightly away from face. Pilot had difficulty finding smoke vent with mask and goggles on.
9-L	Normal, in lap	Close d	Off	N/A	N/A	Off	1 minute, normal breathing <sup>138</sup>	1345	1346	Pilot held mask slightly away from face.
10-L	Normal/ Emerg, in lap	Close d	Off	N/A	N/A	Off	5 secs, normal breathing	1346	1346	
11-L	Normal, in lap,	Close d	Off	N/A	N/A	Off	10 secs, normal breathing	1347	1347	

<sup>138</sup> Observer will speak normally from rear of cockpit for at least one minute.

Task / Seat	O2 Mask Position: PM	Smoke Vent: PM	Goggles : PM	O2 Mask Position: PF	Smoke Vent: PF	Goggles: PF	PM Actions	Start Time	Stop Time	Comments
	smoke evacuative vent open									
<b>Pilots returned mask setting to 100%</b>										

Following the test flight, the participating pilots made the following comments:

- There were no difficulties donning the oxygen mask or smoke goggles.
- There were no difficulties hearing or communicating with the other pilot or ATC as long as the mic was checked on.
- Using forced air (emergency setting) was a little uncomfortable compared to not having the emergency setting on.
- It was difficult to find the switch on the mask to switch between normal and 100%; also to turn on emergency.
- The doors where the oxygen mask is stowed must be closed and the reset switch hit to activate the boom mic.
- It was easier to communicate when not in emergency setting.
- If the flight had been at night, one pilot would have been wearing his glasses and it would have been more challenging to don the smoke goggles because the fit would need to be adjusted.

**Descent for Landing**

**Initial Setup**

- Weight - Normal
- Thrust - Standard Descent Profile
- Config - Standard
- Pressurization - Auto

**Procedure**

- 13) Set Power for normal descent to landing
- 14) Maintain normal airspeed
- 15) Perform standard fuel burn
- 16) Set Standard cabin pressurization

		Flaps/Gear	
Risk	Cond.	Flaps	Operation
		Standard	Establish normal descent to landing

The test flight landed at about 1413 est.

**Ground Time – 90 minutes**

**Procedure**

- 17) Normal Ground Operations for Flight Operations
- 18) NTSB CVR/FDR Specialist conducted CVR download with UPS Tech Ops assistance.
- 19) NTSB Ops/HP Specialists performed Task 2 items in cockpit

		Flaps/Gear	
Risk	Cond.	Flaps	Operation
		Standard	Normal Ground Operations/NTSB Task 2 and Task 3 Preparations

## Task 2

### General Notes

**Task 2:** *Don oxygen mask and smoke goggles and access emergency equipment.*

- Task 2 was conducted on the ground. The NTSB documented task 2 via handwritten notes and photographs.
- For scenarios 10a/b and 11a/b, the participating pilot sat in the captain's seat and donned the oxygen mask and smoke goggles. He attempted to access the emergency equipment (fire extinguisher and portable oxygen bottle) from a seated position. In scenario 10a/b, the seat position was forward and configured for flying. In scenario 11a/b, the seat position was fully back.
- For scenario 12a/b, the participating pilot sat in the left seat and donned the oxygen mask and smoke goggles. He attempted to leave the seat to access the emergency equipment (fire extinguisher and portable oxygen bottle) from a standing position.
- For scenario 13a/b, the participating pilot donned the left seat oxygen mask and smoke goggles. He attempted to access the emergency equipment (fire extinguisher and portable oxygen bottle) from a standing position.

## Task 2: Access emergency equipment

Scenario #	Mask/Goggles	Pilot location	Seat position	Action	Fire ext. reached? Y/N	Distance <sup>139</sup> b/t pilot and fire ext	Oxy bottle reached? Y/N	Distance b/t pilot and oxy bottle	Pilot/Observer comments
10a/b	On	Seated, left seat	Forward	Access fire extinguisher/ portable O2 bottle	No	Left arm: 28" Right arm: 51"	No	Left arm: 23"	Pilot turned to both the left and right to attempt to access the equipment. When turning to the right, the pilot did not have a direct line of access to the equipment because of the jumpseat located behind the left seat.
11a/b	On	Seated, left seat	Full back	Access fire extinguisher/ portable O2 bottle	No	Left arm: 23" Right arm: 42"	No	Left arm: 19"	Pilot turned to both the left and right to attempt to access the equipment. When turning to the right, the pilot did not have a direct line of access to the equipment because of the jumpseat located behind the left seat.
12a/b	On	Seated/ Standing	Forward	Access fire extinguisher/ portable O2 bottle	No	Right arm: 29"	No		It took 12.7 seconds for the pilot to undo his seatbelt, move chair back and attempt to exit chair. Pilot was not able to fully get out of seat.
13a/b	On	Standing	N/A	Access fire extinguisher/ portable O2 bottle	No	Right arm: 29"	No		Pilot was not able to fully get out of seat.

### Additional observations:

- The cabinet housing the emergency equipment was located on the left side of the cockpit, behind the left jumpseat, and was placarded with "Halon/Portable O2/Crash Axe only". However, also located in the cabinet was a harness for use when evacuating an incapacitated crewmember and a life vest which were placed on top of the O2 bottle.

<sup>139</sup> Distance measured from finger tips to edge of cabinet

- The fire extinguisher was mounted upright on the cabinet's left sidewall. The portable oxygen bottle was mounted to the floor of the cabinet. To remove the portable oxygen bottle, the pilot first had to remove the fire extinguisher from the cabinet.
- The oxygen mask hose length measured 56 inches from the captain's panel to the oxygen mask.
- The pilot was not able to access the jumpseat oxygen mask when seated and the seat was forward. The distance between the pilot's fingertips and the mask was 5".
- The pilot was able to access the left jumpseat oxygen mask when the seat was full back and he reached over the back of the seat. He was not able to fully grab the mask from the housing but his finger tips were able to grab the hose and pull it out.
- The pilot would not be able to fly from the left seat when wearing the left jumpseat oxygen mask.
- It took the pilot 16.5 seconds to stand from the left seat, reach for left jumpseat oxygen mask, remove the left seat oxygen mask, don the jumpseat oxygen mask, and reach the cabinet with the emergency equipment.
- The pilot could not remove the portable O2 bottle without first removing the Halon bottle due to the proximity of the left rear jumpseat backing

# I: FLIGHT DATA – FLIGHT GENERAL PROFILE

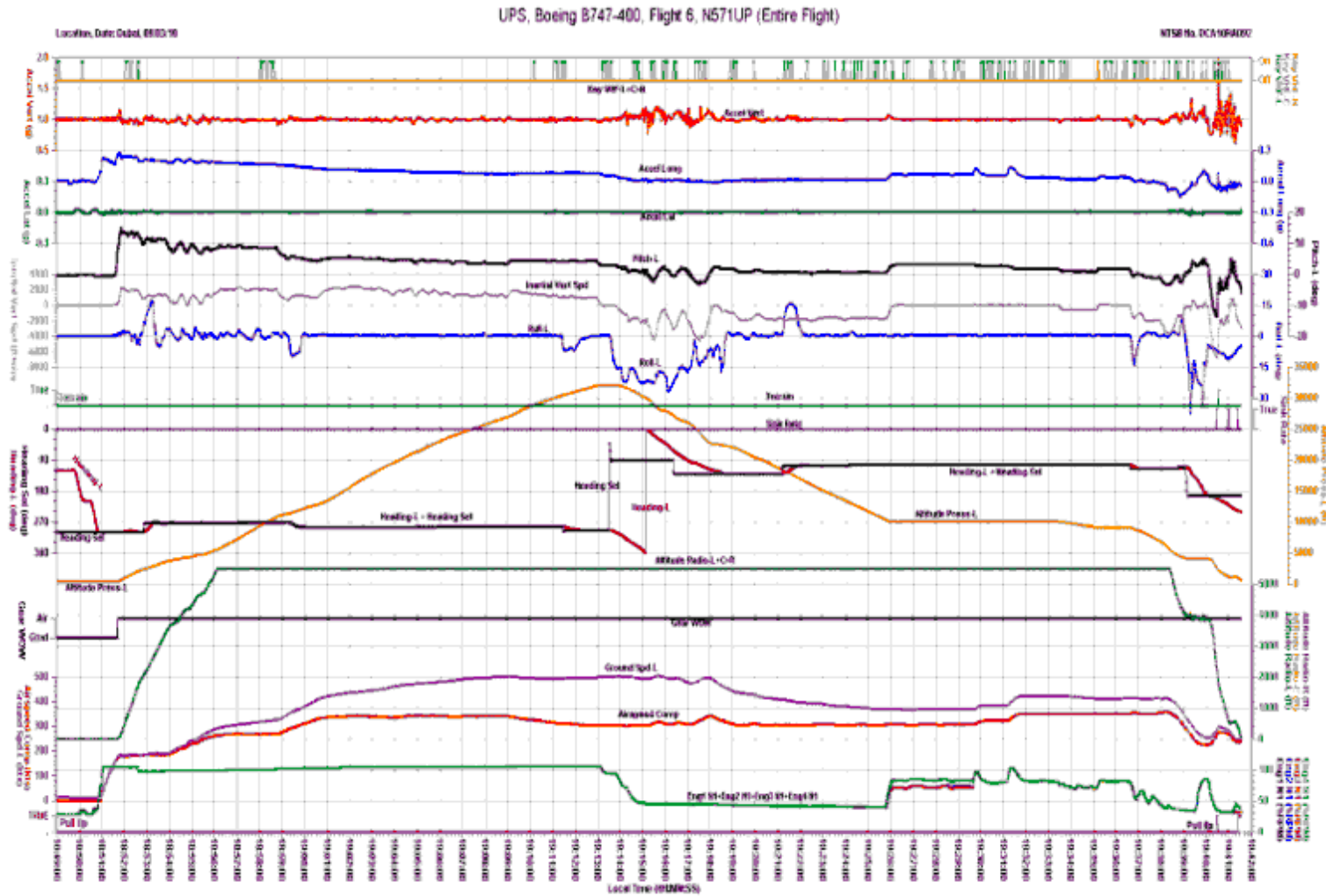



J:SMOKE FIRE AND FUMES IN TRANSPORT AIRCRAFT SPECIALIST PAPER

The Smoke, Fire and Fumes in Transport Aircraft specialist papers are in the public domain and accessible through the Royal Aeronautical Society's web page:

<http://www.aerosociety.com/News/Specialst-Papers>

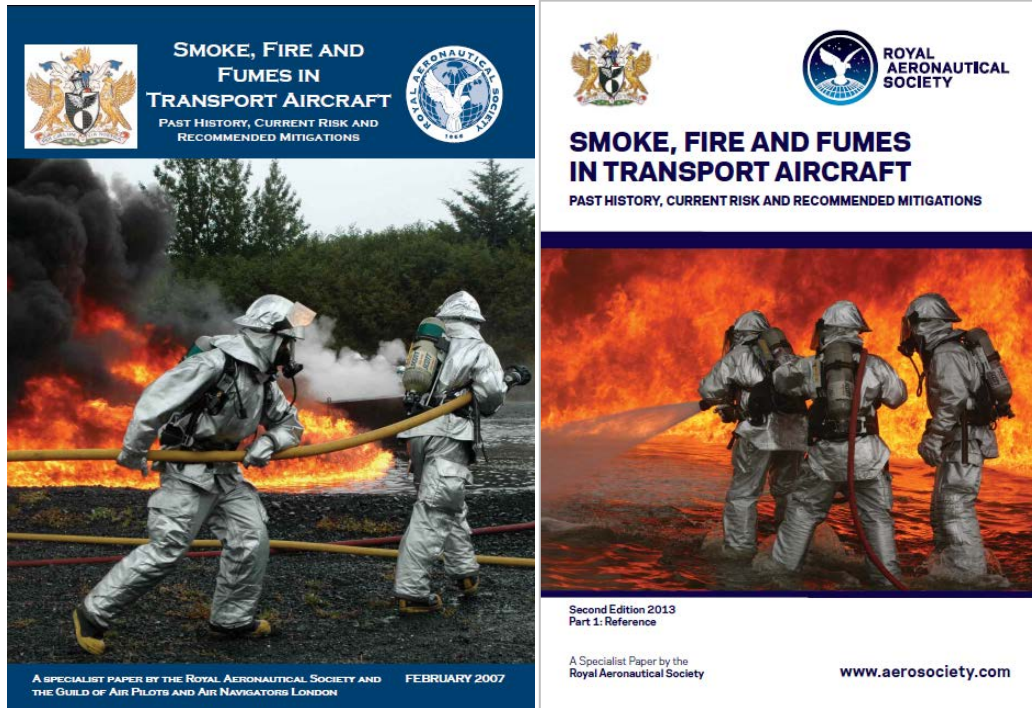

If using an internet search engine to search for these documents, the title and keywords are as follows:

Smoke, Fire and Fumes in Transport Aircraft Past History, Current Risk and Recommended Mitigations: A specialist paper by the Royal Aeronautical Society and the Guild of Air Pilots and Air Navigators London. Feb 2007

## GCAA AIR ACCIDENT INVESTIGATION SECTOR GENERAL INFORMATION

The GCAA Air Accident Investigation Sector [AAIS] contact details and information are listed below.

### Contact Information

Air Accident Investigation Sector

P.O.BOX: 6558

ABU DHABI - UNITED ARAB EMIRATES

TEL: +971 2 444 7666

FAX: +971 2 449 1599

E-mail: [accid@gcaa.gov.ae](mailto:accid@gcaa.gov.ae)

Web: <http://www.gcaa.gov.ae/en/departments/airaccidentinvestigation/pages/default.aspx>

To report an aircraft accident or serious incident contact the GCAA Duty Inspector (24/7) on this number **+971506414667** immediately.